

Medical Physics Board Exam Notebook

Written Sections

2006

Dear Candidate,

Thanks for your \$35.00 purchase of the SCCAAPM's study guide for the ABR. For official information, see <http://www.theabr.org>

The notebook has been assembled for physicists preparing to take the Radiologic Physics section of ABR examination. Included are general requirements for candidates, example questions and comments from previous candidates. It is intended to serve as a study guide for those preparing to take the examination. There is no guarantee that any of these questions will be asked on future exams. It is updated annually.

The format of this document is unchanged changed from last year. It is in electronic .PDF format. Please note that a few documents are quite old and their quality is poor. We have decided to include them anyways. The information is in chronological order, i.e. the latest information is at the end of the documents.

We would like to thank those who have contributed their notes over the many years of this project and request that future exam takers help to perpetuate this notebook.

Alex Li & Tim Paul
SCCAAPM

January 17, 2006

EXAMPLE QUESTIONS
PART 1
WRITTEN EXAMINATION IN PHYSICS

EASY TYPE A

1. Kerma and absorbed dose are related quantities. Beyond the depth of maximum dose the rate of change of these two quantities is best described as:
 - A. dose decreases while kerma increases.
 - B. dose increases while kerma decreases.
 - C. dose decreases slower than kerma.
 - D. dose and kerma decrease equally.
 - E. dose decreases faster than kerma.

2. The indirect action of ionizing radiation refers to the:
 - A. effects of free radicals.
 - B. effects of scattered radiation.
 - C. excitation of a molecule by an electron.
 - D. systemic effect due to secondary emission.
 - E. relative biological effects of different types of radiation.

3. For photons irradiating a material, charged particle equilibrium is established at a particular depth when the:
 - A. particles cross the medium at 90° to the surface.
 - B. ranges of the particles are all $1/\mu$ (one mean free path of the photons).
 - C. number of particles produced at the depth equals the number produced at the surface.
 - D. number of particles produced in a small volume equals the number of particles stopping in that volume.
 - E. positive and negative ions are produced in equal numbers.

4. Quantum mottle has its greatest effect on:
 - A. color imaging.
 - B. slow film imaging.
 - C. low-contrast imaging.
 - D. high-contrast imaging.
 - E. Wiener spectrum imaging.

5. The greatest contribution to the effective dose of the US population is due to:
 - A. radon.
 - B. cosmic rays.
 - C. internal emitters.
 - D. medical procedures.
 - E. household smoke detectors.

6. A large number of photomultiplier tubes is used in a gamma camera primarily to improve the:
- A. contrast resolution.
 - B. photon statistics.
 - C. gamma-ray sensitivity.
 - D. temporal resolution.
 - E. spatial resolution.
7. Appending a zero to the right end of a binary number is equivalent to:
- A. adding 2 to the number.
 - B. dividing the number by 2.
 - C. multiplying the number by 2.
 - D. squaring the number.
 - E. taking the square root of the number.
8. The Curie temperature is the temperature at which:
- A. H_2O exists in three phases of matter.
 - B. thermonuclear disintegration occurs.
 - C. a black body emits neutrinos.
 - D. ferromagnetism is lost.
 - E. the activity of one gram of radium is exactly one Ci.
9. The modulation transfer function (MTF) curve is a plot of:
- A. image contrast versus log relative exposure.
 - B. subject contrast versus image contrast.
 - C. detail detection versus viewing conditions.
 - D. system characteristics versus component characteristics.
 - E. image contrast versus spatial frequency.
10. The most likely effect of irradiation during the preimplantation period of embryonic development is:
- A. carcinogenesis.
 - B. growth retardation.
 - C. malformations.
 - D. mental retardation.
 - E. spontaneous abortion.
11. In ionization dosimetry, a small, gas-filled cavity is placed in a medium. The value of the _____ is required to convert the dose in the gas to the dose in the medium.
- A. energy absorption coefficient of the gas
 - B. energy absorption coefficient ratio of the medium to the gas
 - C. electron fluence across the small cavity
 - D. mass absorption coefficient of the medium
 - E. mass stopping power ratio of the medium to the gas
12. Least-squares fitting of data to a particular curve involves:

- A. Chebychev's inequality.
- B. binomial distributions.
- C. maximizing discrepancies.
- D. minimizing deviations.
- E. minimizing means.

13. Therapy verification images made with 18 MV x rays have less contrast compared with radiographic images. This is mostly a result of:

- A. increased pair production.
- B. increased Compton interaction.
- C. increased photoelectric interaction.
- D. decreased photoelectric interaction.
- E. decreased Compton interaction.

14. The Laplacian operator, ∇^2 , is:

- A. the square of the divergence.
- B. $-\nabla$.
- C. $-\nabla^2$.
- D. the rms of the first derivative.
- E. the rms of the second derivative.

15. The BEIR V and the UNSCEAR (1986) estimate of the mutation doubling dose for humans is _____ Gy.

- A. 0.001
- B. 0.01
- C. 0.1
- D. 1
- E. 10

16. In your frame of reference, an object is traveling near the speed of light. Compared with its dimensions at rest:

- A. only dimensions parallel to its motion are different.
- B. only dimensions perpendicular to its motion are different.
- C. all dimensions are changed.
- D. all dimensions are the same.
- E. parallel and perpendicular dimensions change in equal but opposite amounts.

17. In a diagnostic x-ray facility, a typical lead shielding thickness of a wall is _____ mm.

- A. 0.2
- B. 1
- C. 5
- D. 10
- E. 15

18. In a mammalian cell, the most sensitive target for radiation damage is the:

- A. cell wall.
- B. endoplasmic reticulum.
- C. mitochondria.
- D. Golgi apparatus.
- E. deoxyribonucleic acid.

19. The greatest dose from 14 MeV neutrons absorbed in tissue is provided by:

- A. recoil protons.
- B. direct ionization.
- C. delta rays.
- D. induced radioactivity.
- E. gamma rays.

20. Double precision arithmetic refers to:

- A. representing floating point numbers as integers.
- B. summing a series using smaller increments.
- C. keeping track of the error of each operation and correcting the final answer.
- D. using twice as many bits to represent a floating point number.
- E. normalizing floating point numbers to eliminate leading zeroes.

21. One gram of tissue receives a dose of 2 Gy in a certain radiation beam. Neglecting any attenuation 2 grams of tissue located at the same point in the same radiation beam would receive a dose of _____ Gy.

- A. 0.5
- B. 1
- C. 2
- D. 4
- E. 8

22. The image formed by light passing through a pinhole is:

- A. real and erect.
- B. real and inverted.
- C. virtual and erect.
- D. virtual and inverted.
- E. virtual and magnified.

23. A lecturer's voice-intensity level is 1000 times greater than the level of a normal speaking voice. What is the difference in decibels?

- A. 10
- B. 13
- C. 30
- D. 100
- E. 300

24. What device requires the most stable voltage power supply for reproducible operation?

- A. thermocouple
- B. photovoltaic cell
- C. proportional counter
- D. ion-chamber survey meter
- E. Geiger-Mueller survey meter

HARD TYPE A

1. A primary barrier is designed to shield a well-collimated monoenergetic photon source placed 4 m from the point of interest. If the source is moved to 2 m, the barrier thickness must be increased by _____ HVL to provide equivalent protection?
 - A. 5
 - B. 3
 - C. 2
 - D. 1
 - E. 0

2. A 5 MeV electron will liberate how many coulombs of charge of one sign while coming to rest in air?
 - A. 2.7×10^{-17}
 - B. 2.4×10^{-14}
 - C. 8.0×10^{-12}
 - D. 2.6×10^{-11}
 - E. 2.8×10^{-9}

3. If the TVL for a radioactive source is 1.0 mm of lead, the fifth value layer is _____ mm of lead.
 - A. 0.9
 - B. 0.7
 - C. 0.5
 - D. 0.4
 - E. 0.2

4. An ideal gas has a pressure of 1 atm inside a closed, 2 liter vessel at 20°C. If the temperature were raised to 25°C, the gas pressure is _____ atmospheres.
 - A. 0.80
 - B. 0.98
 - C. 1.02
 - D. 1.25
 - E. 2.03

5. To reduce image noise by a factor of 10, the number of information carriers must be increased by a factor of:
 - A. 3.1

- B. 5
- C. 10
- D. 20
- E. 100

6. The solid angle subtended by a 100 cm^2 circular detector at a distance of 1 m is _____ steradians.

- A. 0.01
- B. 0.03
- C. 0.12
- D. 2.0
- E. 6.5

7. The average gamma-ray photon fluence incident on an Anger camera crystal is $4000 \text{ photons/cm}^2$. If the detection efficiency of the crystal is 50%, the percent deviation in the counts for a one cm^2 area is _____.

- A. 1.6
- B. 2.2
- C. 2.5
- D. 3.2
- E. 3.5

8. The electric potential at radius r between the inner and outer electrodes of a cylindrical ionization chamber is

$$V(r) = V_0 \log_e(r/a)$$

where V_0 is 130 volts, a is the radius of the center electrode (0.05 cm) and the radius of the outer electrode is 0.5 cm. The **electric field** at the surface of the center electrode is _____ volts/cm.

- A. -2600
- B. -2100
- C. -1333
- D. -667
- E. -600

9. A group of cancer patients have lifetimes that are normally distributed with a mean of 30 months and a standard deviation of 2.5 months. What percentage of these patients will survive at least 34 months? (See the standard error function table below.)

- A. 1.5
- B. 2.2
- C. 5.5
- D. 10.5
- E. 20.0

X 0 1 2 3 4 5 6 7 8 9

0.0	.5000	.6040	.5080	.5120	.5160	.5199	.5239	.5279	.5319	.6359
0.1	.6398	.5438	.6478	.5517	.5557	.5596	.5636	.5675	.5714	.5754
0.2	.6793	.5832	.5871	.5910	.5948	.5987	.6026	.6064	.6103	.6141
0.3	.6179	.6217	.6255	.6293	.6331	.6368	.6406	.6443	.6480	.6517
0.4	.6554	.6591	.6628	.6664	.6700	.6736	.6772	.6808	.6844	.6879
0.5	.6915	.6950	.6985	.7019	.7054	.7088	.7123	.7157	.7190	.7224
0.6	.7258	.7291	.7324	.7357	.7389	.7422	.7454	.7486	.7518	.7649
0.7	.7580	.7612	.7642	.7673	.7704	.7734	.7764	.7794	.7823	.7852
0.8	.7881	.7910	.7939	.7967	.7996	.8023	.8051	.8078	.8106	.8133
0.9	.8159	.8186	.8212	.8238	.8264	.8289	.8316	.8340	.8365	.8389
1.0	.8413	.8438	.8461	.8485	.8508	.8531	.8554	.8577	.8599	.8621
1.1	.8643	.8665	.8686	.8708	.8729	.8749	.8770	.8790	.8810	.8830
1.2	.8849	.8869	.8888	.8907	.8925	.8944	.8962	.8980	.8997	.9015
1.3	.9032	.9049	.9066	.9082	.9099	.9115	.9131	.9147	.9162	.9177
1.4	.9192	.9207	.9222	.9236	.9251	.9265	.9279	.9292	.9306	.9319
1.5	.9332	.9345	.9357	.9370	.9382	.9394	.9406	.9418	.9429	.9441
1.6	.9452	.9463	.9474	.9484	.9495	.9505	.9515	.9525	.9535	.9545
1.7	.9554	.9564	.9573	.9582	.9591	.9599	.9608	.9616	.9625	.9633
1.8	.9641	.9649	.9656	.9664	.9671	.9678	.9686	.9693	.9699	.9706
1.9	.9713	.9719	.9726	.9732	.9738	.9744	.9750	.9756	.9761	.9767

Error function table for question 9 above.
 $erf(x)$

10. In a 4 MV linear accelerator, the speed of an electron striking the target is _____ c, where c is the velocity of light. Note that $m_0c^2 = 0.51 \text{ MeV}$.

- A. 0.887
- B. 0.942
- C. 0.984
- D. 0.987
- E. 0.994

11. A point source of radiation is situated on the central axis, 0.2 m from the center of a circular detector with a 0.05 m radius. The geometrical efficiency of the detector for this point source is _____.

- A. 0.16
- B. 0.13
- C. 0.11
- D. 0.060
- E. 0.016

12. At 75° F, an ionization chamber open to the atmosphere should have its reading "temperature corrected" by multiplying the reading by _____.

- A. 0.9936
- B. 1.0032
- C. 1.0064
- D. 1.0859
- E. 1.1029

13. A mammoth bone is found to have a ^{14}C specific activity that is 5.0% of the atmospheric value. The mammoth died _____ years ago. The half life of ^{14}C is 5730 years.

- A. 22,920
- B. 24,765
- C. 28,650
- D. 63,030
- E. 114,600

14. A 1024 x 1024 digital image with 64 shades of gray is to be transmitted at the rate of 10^5 baud (bits/s). The image can be transmitted in approximately:

- A. 1 s.
- B. 3 s.
- C. 6 s.
- D. 1 min.
- E. 6 min.

15. On a 16-bit personal computer, an integer variable is allotted 2 bytes of memory. If one bit is used for the algebraic sign, then the range of such a variable is:

- A. 0 to 512.
- B. 0 to 32,767.
- C. -16,384 to 16,383.
- D. -32,768 to 32,767.
- E. -65,536 to 65,535.

16. At a radiologist's desk, the instantaneous air kerma rate through a wall cassette holder is 5.0 mGy/h during normal chest exposures of 10 mAs with the unit operating at 100 kV and 100 mA. The maximum air kerma at the radiologist's desk during 1 week for 200 chest films would be approximately _____ mGy?

- A. 0.0028
- B. 0.028

- C. 0.28
- D. 2.8
- E. 28

17. The counting rate of a radioactive sample (including background) is 1200 counts in one minute. The background counting rate is 400 counts in one minute. What is the percent standard deviation of the net count rate?

- A. 2.5
- B. 3.0
- C. 3.5
- D. 5.0
- E. 6.8

18. An ionization chamber of 2 cm^3 is placed in a radiation field of 100 R/s. The current generated is how many amperes ($\rho_{\text{air}} = 0.0013 \text{ g/cm}^3$)?

- A. 5.1×10^{-11}
- B. 6.7×10^{-10}
- C. 5.1×10^{-9}
- D. 6.7×10^{-8}
- E. 5.1×10^{-7}

19. The dose rate at 1 m from a shielded source is 2 mSv/wk. The additional shielding required to reduce the dose rate at 2 m to 0.1 mSv/wk is _____ mm of lead. Note the HVL for the shielded source is 6 mm of lead.

- A. 0
- B. 14
- C. 20
- D. 26
- E. 38

20. The mass attenuation coefficient of bone, (density of $1.8 \times 10^3 \text{ kg/m}^3$) is $0.02 \text{ m}^2/\text{kg}$ for an 80 keV gamma ray. A beam of 80 keV photons will be _____% attenuated by a slab of bone 0.04 m thick.

- A. 36
- B. 45
- C. 55
- D. 64
- E. 76

21. A linear source has a nonuniform activity. The activity per unit length is:

$$A(x) = 10x^2 \text{ } \mu\text{Ci/cm}^3 \text{ for } 0 \leq x \leq 10 \text{ cm}$$

The activity is 0 elsewhere. The centroid, \bar{x} , of the activity distribution occurs at $x =$ _____ cm.

- A. 7.5
- B. 7.0
- C. 6.5
- D. 6.0
- E. 5.0

22. For a true count rate of $10,000 \text{ sec}^{-1}$ and a non-paralyzable counting system with a dead time of $5 \mu\text{s}$, the loss in the observed count rate is _____%.

- A. 0.05
- B. 0.1
- C. 0.5
- D. 2.5
- E. 5.0

23. A one microfarad capacitor is connected in series with a 1×10^8 ohm resistor. At time $t = 0$, a 100 volt power supply is connected to the circuit. At 100 seconds, what is the voltage across the capacitor? (See Figure below.)

- A. 63.2
- B. 70.7
- C. 95.0
- D. 98.6
- E. 100.0

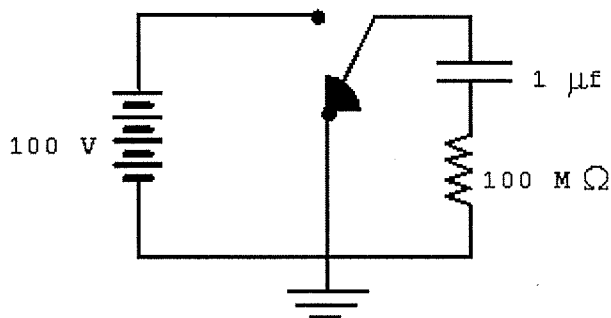

Figure for question number 23 above.

24. Which combination of three numbers below would be the representation of the decimal number 17 in binary, octal, and hexadecimal formats, respectively?

- A. 10001, 21, 11
- B. 11101, 21, 10
- C. 10001, 39, 101
- D. 11101, 117, 101

E. 1111, 111, 11

25. A signal ranging from 0 to 10 volts is to be digitized with a resolution no worse than 10 mV. The A/D converter should have at least how many bits?

- A. 6
- B. 8
- C. 10
- D. 12
- E. 16

ANSWER KEY

Question #	Easy A	Hard A
1	D	C
2	A	B
3	D	B
4	C	C
5	A	E
6	E	A
7	C	A
8	D	A
9	E	C
10	E	E
11	E	E
12	D	C
13	D	B
14	C	D
15	D	D
16	A	B
17	B	D
18	E	D
19	A	B
20	D	E
21	C	A
22	B	E
23	C	A
24	C	A
25		C

Representative Computer-based Questions for the Oral Examination in Diagnostic Radiologic Physics:

- *Radiation Protection and Safety*

Question - You are asked to provide a shielding design for a radiographic room in a new out-patient center. Comment on the proposed room layout. What shielding would be required for the room behind the chest cassette? What additional information would you need?

- *Patient Related Measurements*

Question - The patient shown on the film is concerned about the radiation exposure to her baby. How would you evaluate the dose and what advice could you give about possible effects? Would the effects be different if the exposure occurred earlier in pregnancy?

- *Image Acquisition, Processing and Display*

Question - Compare these two radiographs. Which is preferable and why? What is the likely cause of the problem with the poorer radiograph? What can be done to reduce the effect of this cause?

- *Calibration Quality Control and Quality Assurance*

Question - What type of imaging equipment is being tested? What specific measurement is being made? Is the setup correct? What are the current ACR standards for these measurements? What would you do if the measurement exceeds the recommended value?

- *Equipment*

Question - What kind of phantom is this? What test is it used for? Critique the images?

ABR EXAMINER

VOLUME 7
NUMBER 1

THE PRESIDENT'S MESSAGE

T As my last President's Message, I would like to share some

thoughts about learning/teaching which span my professional experience and academic career (1970-2002). Why? Because the experience is a potential mirror of the past and perhaps a stimulus to think about a vision of the future. I had superb clinical diagnostic radiology training because of an outstanding faculty, dedicated teachers and my first true mentors. I finished three years of diagnostic radiology training in 1970, passed the ABR written examination and successfully passed the Oral Boards in 1971. In those days the oral examination was given one year after completion of residency. Today, many of us teach the way we were taught and prepare our residents for examinations as our teachers did. Has anything changed? Should it?

The following are some of my thoughts:

- I am first a physician and second a diagnostic radiologist and reminded often that the needs of our patients come first. Technology transformed the field of diagnostic radiology and the impact of imaging on patient care. Many diagnostic radiologists became image- rather than patient-focused. Physician teamwork, collegiality and integrated patient management are fundamentals of the highest quality of care.
- Basic and clinical research are essential for the future of diagnostic radiology, and we must align training programs and incentives to meet these research objectives. Changes at the NIH and NIBIB provide us with an opportunity. Are we prepared to take advantage of the opportunity?
- Academic medical centers and academic faculty are facing extreme pressure on time to teach and to explore scientific investigation, and teaching in the private practice of radiology experiences similar pressures.



Robert R. Hattery, MD

COMMENTS FROM THE EXECUTIVE DIRECTOR

M. PAUL CAPP, MD

EXECUTIVE DIRECTOR'S REPORT "STUFF AND MORE STUFF"

Saying Goodbye: I quote Gibran from "The Prophet":

"And to love life through labor is to be intimate with life's innermost secret."

My 21 years with the American Board of Radiology, the last nine serving as Executive Director, have indeed been a labor of love beyond description. The personal satisfaction I have received in playing a small part in the growth of the ABR changes, strategies, and impact on our discipline is also beyond description. Thanks to all the trustees who made this happen. Please welcome my successor, Bob Hattery, from the Mayo Clinic, who will take over some time this summer.

New Building: To be cost-effective (leasing vs. owning) the ABR has constructed a 31,000 sq. ft. building in Tucson, Arizona which will permanently house the entire office. We currently occupy the top floor, and the bottom floor will be leased. The ABR is pleased with the overall construction (figure on next page).

New Trustee: I am very pleased to announce that N. Reed Dunnick, MD was elected to replace Bob Hattery as a new trustee when Bob steps down from the Board. Reed joins the trustees while serving as Professor and Chair of the Department of Radiology at

continued on page 2

Inside...

Executive Director's Report	2
The President's Message	3
Physics Update	4
Radiation Oncology Report	5
Exams Summary	
Written Diagnostic Radiology	6
Oral Diagnostic Radiology	6
CAQ	7-8
Written Radiation Oncology	9
Oral Radiation Oncology	9
Oral Physics	10
Schedule	12

continued on page 3

EDITORS

M. Paul Capp, MD
Steven A. Leibel, MD

PRESIDENT

Robert R. Hattery, MD

VICE PRESIDENT

William R. Hendee, PhD

SECRETARY/TREASURER

Steven A. Leibel, MD

DIAGNOSTIC RADIOLOGY

Phillip O. Alderson, MD
Gary J. Becker, MD
George S. Bisset III, MD
Robert R. Hattery, Jr., MD
Valerie P. Jackson, MD
Robert R. Lukin, MD
John E. Madewell, MD
Christopher Merritt, MD
Andrew K. Poznanski, MD
Anthony V. Proto, MD
Anne C. Roberts, MD
Robert J. Stanley, MD
Michael A. Sullivan, MD
Kay H. Vydareny, MD
James E. Youker, MD

RADIATION ONCOLOGY

Jay R. Harris, MD
Richard T. Hoppe, MD
David H. Hussey, MD
Larry E. Kun, MD
Steven A. Leibel, MD
H. Rodney Withers, MD

RADIOLOGIC PHYSICS

William R. Hendee, PhD
Bhudatt Paliwal, PhD
Stephen Thomas, PhD

EXECUTIVE DIRECTOR

M. Paul Capp, MD

ASSISTANT EXECUTIVE DIRECTORS

Lawrence W. Davis, MD
Anthony V. Proto, MD
Bhudatt Paliwal, PhD

THE AMERICAN Board of Radiology

5441 E. WILLIAMS BLVD.
SUITE 200
TUCSON, ARIZONA 85711
520-790-2900
FAX: 520-790-3200
WEB: WWW.THEABR.ORG

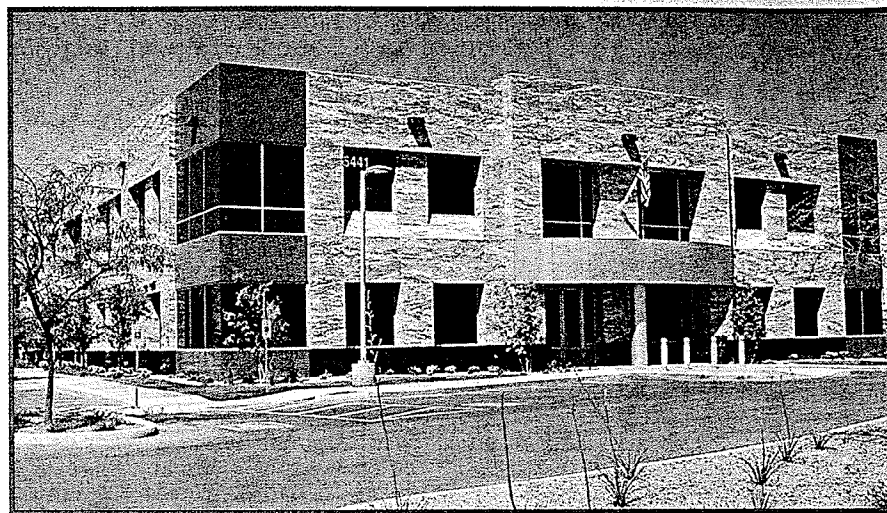

EXECUTIVE DIRECTOR'S

continued from page 1

the University of Michigan. He comes to us with a strong background in GU radiology and will serve the Board as category chair, responsible for both the written and oral examinations. His strong background will be a considerable asset to the Board.

Newsletter: The "ABR Examiner" continues to reach all diplomates in May and November of each year. I am personally very pleased to have played a small role, along with the ABR trustees, in initiating this newsletter during my tenure as Executive Director. We all feel very strongly that the newsletter has served to improve communication, and most importantly, to keep all diplomates and residents well informed of Board activities.

President of ABMS: The Board is pleased that ABR trustee Jim Youker, MD, from the Medical College of Wisconsin, has now completed his second year as President of the American Board of Medical Specialties. Jim has done an excellent job in leading the 24 member boards of ABMS, particularly through a difficult transitional period in developing the Maintenance of Certification programs. The Board congratulates him on this esteemed honor; he has represented our discipline well. We thank him for this huge responsibility and a job well done.

Holman Research Tract Pathway: I urge all programs and program directors to give consideration to guiding medical students with an interest in academic radiology towards applying for this very important research pathway. Details can be found on the web site. The ABR reminds all that the RSNA, R&E

Foundation, is accepting grant proposals from all Holman Research Tract Pathway designees.

Certification, Maintenance of Certification and Competency:

The ABMS Assembly, representing the 24 member boards, has now officially adopted the four components of Maintenance of Certification: Professionalism, Lifelong Learning and Self-Assessment, Cognitive Expertise (the test), and Practice Performance. The ABR and ACR have been meeting the past two years and developing a strategy toward the preparation of these components. To this end, there was a most important meeting in December of '01 of the ABR of sponsoring societies (ACR/ARRS/AUR/RSNA/ASTRO/AAPM/ARS). Whereas in the past only ABR/ACR discussed matters of maintenance of certification, the addition of other members will allow information to be passed to all their constituents regarding the importance and future mechanisms of MOC. The committee will continue to discuss details of MOC and also serve as the group to be informed of the progress of the MOC of Physics, Radiation Oncology and Diagnostic Radiology (including its four subspecialties). ABR committees of Radiologic Physics, Radiation Oncology and Diagnostic Radiology have been, and are currently, developing guidelines for these components. Details will be forthcoming in the future.

Time-Limited Certificates and Recertification Examinations:

Since time-limited certificates began in Pediatric and Vascular and Interventional Radiology in '94, and Neuroradiology and Radiation

continued on page 5

PRESIDENT

continued from page 1

- You get what you measure! Are we measuring the right things? "If our diagnostic radiology residency programs are to provide optimal training for the next generation of radiologists, we must replace the monolith of accuracy with a more complete model of radiologic performance."—Gunderman and Nyce

- Residents spend too much time "studying for the Boards" and not enough time learning, analyzing, gaining sound judgment, caring for patients, doing basic and clinical research, developing hypotheses and refining the traits of physicians. No matter how hard the ABR and academic faculty try to change resident behavior, paranoia and cramming as part of the preparation for Oral Boards have not changed significantly in my 32-year experience.

- Diagnostic Radiology has been a fabulous career choice and should attract the best and brightest trainees now and in the future. How will they learn, how and what will we teach, and how will we measure the outcome?

- My educational experience as a resident was primarily an apprenticeship. My wife Diane and daughter Angie were trained and educated to teach at the high school and college levels. I was trained as a physician and my son Mike was educated with an MBA. Yet, all of us teach! Were we prepared appropriately? What should be the credentials of teachers and the experience of students in the future?

One of the stated purposes of the ABR is to "improve the quality of graduate education in the medical specialties in the radiologic sciences." Regarding the educational experience, I believe advances in information management and communication technologies such as the worldwide web, the next Generation Internet, distance education, Asynchronous Learning Network, and intelligent infrastructure will fundamentally change the educational and the learning environment. In the future, staff, residents, and students will be able to acquire most of their instructional material on-line. Patient simulators will enable faculty, residents and students to learn procedures, and web-based instruction for interventional radiology training will become commonplace. Networking and other technologies will aid faculty in designing and teaching residents at the point of care. Learning will be more self-directed and will require a different set of educational skills. The rate of

new research information is literally exploding and access to new knowledge will need to be instantaneous. Time for teaching and for learning has been compressed beyond the effectiveness of current teaching models. Change needs to permeate throughout the educational years in undergraduate schools, medical schools, clinical training, and residency and fellowship programs. The need for expert teachers to keep up with advances in their field, to integrate them into teaching/learning systems, and to facilitate learning will not change. The tools they employ, however, will undergo profound changes.

The following are some of the key problems that must be recognized:

- We need time to teach.
- Learning requires multiple sources of knowledge.
- Decreasing "cycle time" of knowledge and skills and increasing amount of information are necessary for effectiveness.
- A profound culture shift has taken place. Future generations will expect a computer on every desktop and to receive knowledge and educational interactive teaching programs via computer systems.

Teaching and learning in the twenty-first century will require new approaches. Perhaps insights from T. S. Eliot, "Where is the wisdom we have lost in knowledge? Where is the knowledge we have lost in information?" and Benjamin Franklin, "Tell me and I forget; teach me and I remember; involve me and I learn." will evoke change.

If we are going to make change, perhaps Rabbi Hillel's comments should be our guiding principles. "If not us, who? If not now, when?"

SUGGESTED READING:

1. Gunderman RB, Nyce JM, et al. The tyranny of accuracy in radiologic education. *Radiology* 2002;222:297-300.
 2. MacLaurin D. The year to learn: how learning styles differ across generations. *Convence* 2001;16:50-52.
 3. Zemke R, Zemke S. Thirty things we know for sure about adult learning. *Convence* 2001;16:6-8.
- Rath D, Davis, D, Silver I, Greco M, Snell L. Presentation skills and interactivity in large groups. Handout developed by Continuing Education, Faculty of Medicine, University of Toronto. ■

PHYSICS UPDATE

BY WILLIAM R. HENDEE, PHD; BHUDATT PALIWAL, PHD;
STEPHEN THOMAS, PHD

MAINTENANCE OF CERTIFICATION IN MEDICAL PHYSICS

Beginning this year (2002), certification in diagnostic radiological physics, medical nuclear physics, and therapeutic radiological physics by the American Board of Radiology (ABR) will result in issuance of a 10-year time-limited certificate. To sustain their certification beyond the 10-year limit, physicists will need to engage in the ABR's program for Maintenance of Certification (MOC). Additional information about the MOC program for medical physicists is available on the ABR website (www.theabr.org).

The ABR's MOC program for medical physicists has 4 elements, each to be completed over the 10-year period beginning with the date of certification. Once these are completed, the physicist may request a 10-year extension of certification in the field(s) in which he or she was originally certified. The 10-year extension begins on the 10th anniversary of original certification. All information required to extend certification should be submitted in the final year before expiration of certification.

Element 1: Continuing Education Credits

A certified medical physicist is expected to engage in life-long learning in his or her discipline. This learning process includes educational activities such as participation in courses and scientific meetings recognized for continuing education credit by the Commission on Accreditation of Medical Physics Education Programs (CAMPEP). It also includes engagement in other opportunities for professional growth, including learning exercises as a student or teacher, publications such as scientific papers, learned treatises, task group reports, voluntary organizations such as the National Council on Radiation Protection and Measurements (NCRP), the International Commission on Radiological Protection (ICRP), and programs and committees of scientific, professional and educational societies related to the physicist's area of interest. Different levels of credit are granted for these and other learning activities. The individual physicist is responsible for maintaining a cumulative record of continuing education credits. A formatted and password-protected file will be available soon on the ABR website to aid in maintaining the record.

Element 2: Self-Evaluation

A record of employment, major medical physics responsibilities, and involvement in delivery of medical physics services must be submitted as part of the application for renewal of medical physics certification. A form for compilation of this record will be available soon on the ABR website.

Element 3: Letters of Attestation

Two statements attesting to the physicist's competence and diligence in meeting responsibilities must be supplied in the application for certification extension. The statements must come from individuals who are familiar with the physicist's current contributions. One statement should be provided by a senior ABR-certified medical physicist and the other from a senior ABR-certified physician. A form for submission of these statements will be available soon on the ABR website.

Element 4: Examinations

To receive an extension of certification, the physicist is required to pass 3 examinations during the 10-year certification period. The examinations will be available in 3-year increments beginning in 2004 (i.e., 2004, 2007, 2010), and will focus on new information in medical physics. This focus implies that the examination will focus on new practical information, and not on basic information on which the physicist was examined during his or her original certification. It will include materials such as NCRP, ICRP, ICRU and AAPM task force reports, new dosimetry and calibration protocols, seminal journal articles, data on emerging imaging modalities, and other information considered essential to the practice of medical physics. This information will be identified on the ABR website. Each examination will consist of 50 multiple-choice questions which the candidate can answer on-line. The examination can be taken as often as necessary until the candidate passes. Passage of the examination provides a certificate of completion that can be submitted with the application for renewal of certification. The candidate can take each examination anytime after it has been made available on the ABR website. Candidates are encouraged to take the examinations soon after they are available, however, so that the work to extend the certificate is not compressed into too short a time period before extension is needed.

Physicists certified by the American Board of Medical Physics have been issued 10-year time-limited certificates since 1992. ABMP-certified physicists who have requested a Letter of Certification Equivalence from the ABR have received a letter with an expiration date identical to that on the ABMP certificate. These individuals may have this date extended by engaging in the ABR's Maintenance of Certification program. To obtain an extension of the date of expiration of the letter of equivalence, the physicist should make a request to the ABR at least 3 months before the expiration date.

The American Board of Radiology is committed to assisting medical physicists in fulfilling the expectations of patients and the public for demonstration of continued competence in the practice of their profession. ■

RADIATION ONCOLOGY REPORT

By DAVID H. HUSSEY, MD

Relatively few changes are planned for the radiation oncology examination process this year. This is mainly because a significant review of the radiation oncology process is planned for the year 2003-2004.

At present, radiation oncology residents are allowed to sit for the written examination in the fall of their final year of residency. However, this will soon not be the case. Beginning with the class completing training in the year 2004, residents will not be eligible to sit for the examination until they have completed their training.

It is important to realize that this is similar to almost all other specialties. Although diagnostic radiology residents will still be allowed to take the examination during the last year of their residency, the certification examination for most all other specialties are delayed until the residents have completed their residency.

Because the class of 2004 will be delayed a year, the ABR anticipates that there will be relatively few radiation oncologists taking the written examination in radiation oncology in the Fall of 2003, or the oral examination in the Spring of 2004.

The ABR plans to use this time for a major review of the written examinations for both primary certification and re-certification. The questions in the databank will be reviewed even more carefully than usual for relevance and clarity, and the distribution by tumor site and content area will be reassessed for each of the written examinations.

EXECUTIVE DIRECTOR'S *continued from page 1*

Oncology in '95, committees have been working hard in developing the recertification examinations to be ready in 2003, 2004 and thereafter. These will all be computerized exams and available at sites in Tampa, Florida; Chicago, Illinois; and Tucson, Arizona. All those with time-limited certificates will be advised approximately one-year before their certificates expire with details of the MOC examination.

Thank you: In the year 2001, ABR examinations totaled 16,499, with 13,992 in Diagnosis (1,075 in Certificates of Added Qualifications), 1,483 in Radiation Oncology and 1,004 in Radiologic Physics. These numbers include all

Each year a concerted effort is made to assure that the examinations are up-to-date — that the examinations reflect the current state of practice of radiation oncology, the distribution of questions is appropriate, and the difficulty of the examination does not change significantly from year to year.

The ABR uses several sophisticated psychometric techniques; i.e., equating, procedures, and periodic Angoff analyses, to assure that the difficulty of the examination stays relatively uniform from year to year. To assure that the examination is relevant and up-to-date, the ABR uses a panel of experts in the field, as well as input from the candidates themselves.

The candidates' surveys, which are administered at the end of each written examination and at the end of the day for the oral examination, are very helpful in this regard. For example, the numbers of calculations on the physics exam have been decreased slightly over the past several years because of concerns expressed by the residents. Also, the distribution of questions by tumor site will be modified this year, partly upon the basis of candidate surveys.

Over the past several years, the ABR has been evaluating the content for the cancer and radiation biology examination in order to make it better reflect the changing knowledge base of the field. The biology teachers in all residency programs were surveyed to get their opinion of what radiation oncologists should know. The biologists then met at the 2000 and 2001 ASTRO meetings to establish a new curriculum for cancer and radiation biology. The ABR will use this information to modify the examination over the next few years. ■

the individual written and oral examinations. As my last parting comment, I want to thank each and every one of you, and that includes hundreds and hundreds of diagnostic radiologists, radiation oncologists and radiologic physicists who have contributed to the great details of developing individual questions for the written examinations, and so many of you who have given your time and individual effort for the oral examinations over the past nine years. I wish I could personally shake each hand. There are no words to express my appreciation, so all I can say is thank you for the past nine years and for raising the bar in radiology for better patient care. ■

EXAMINATION STATISTICAL SUMMARY

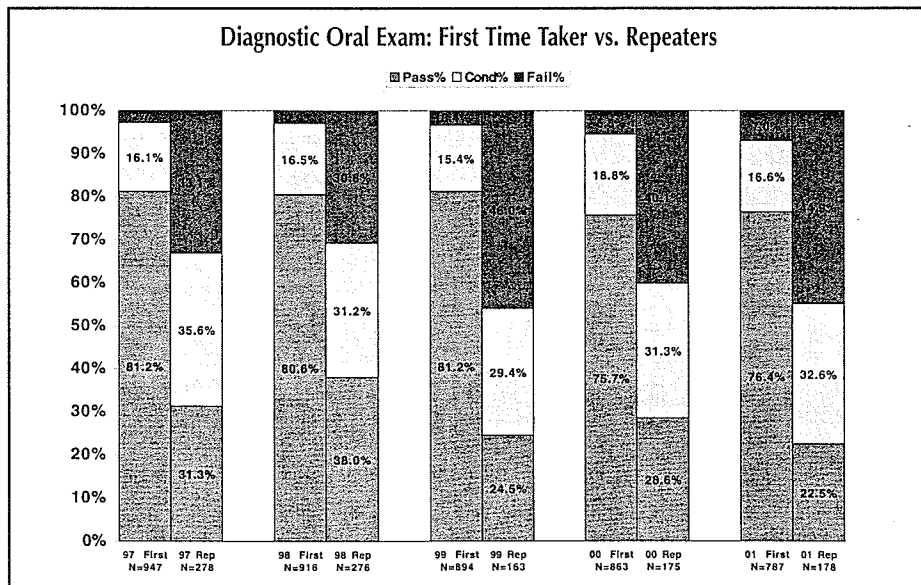
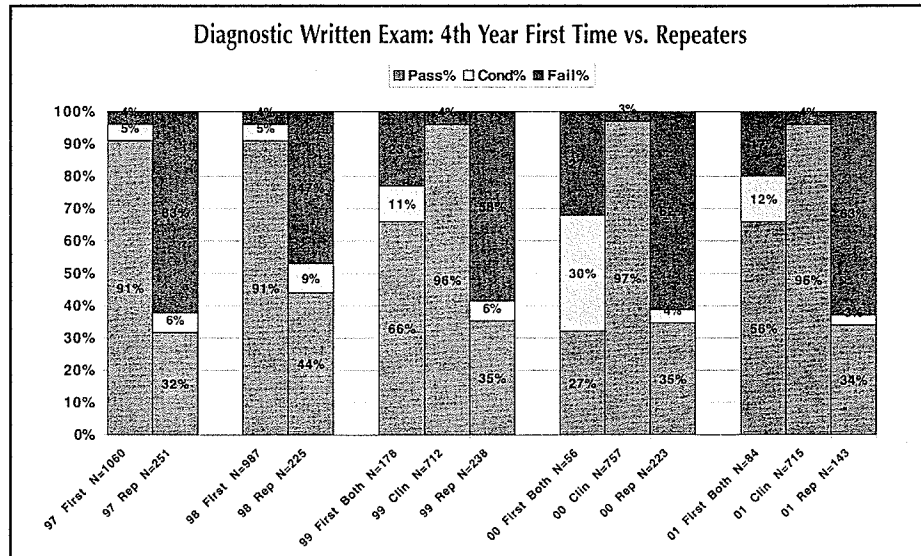
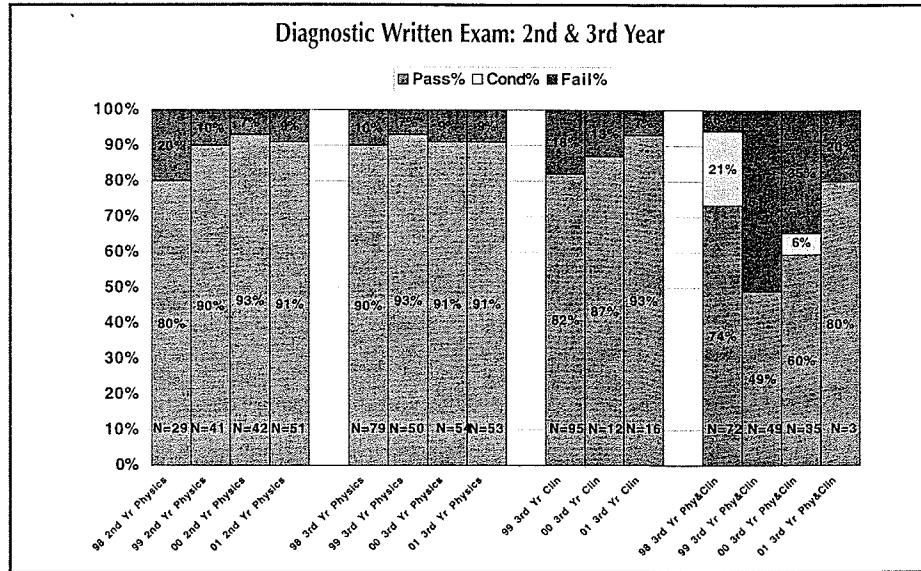

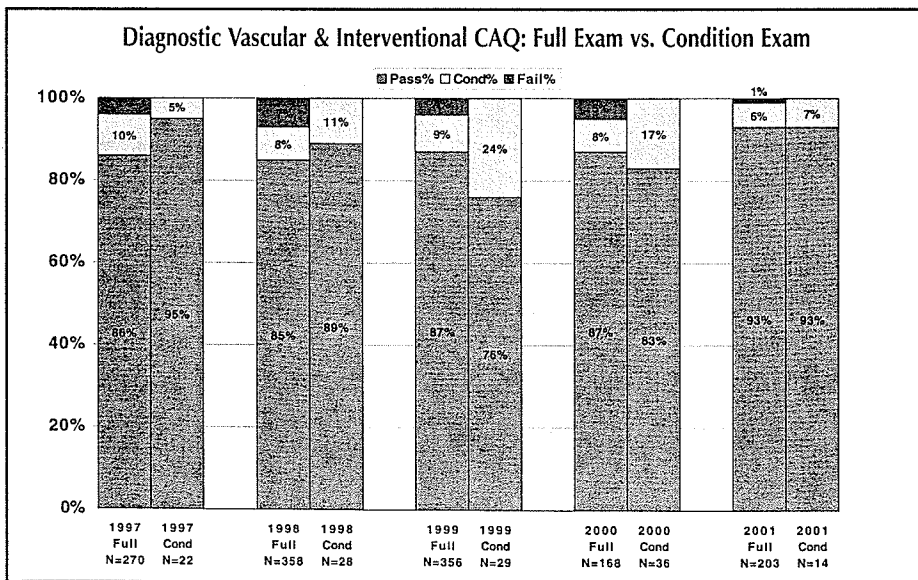
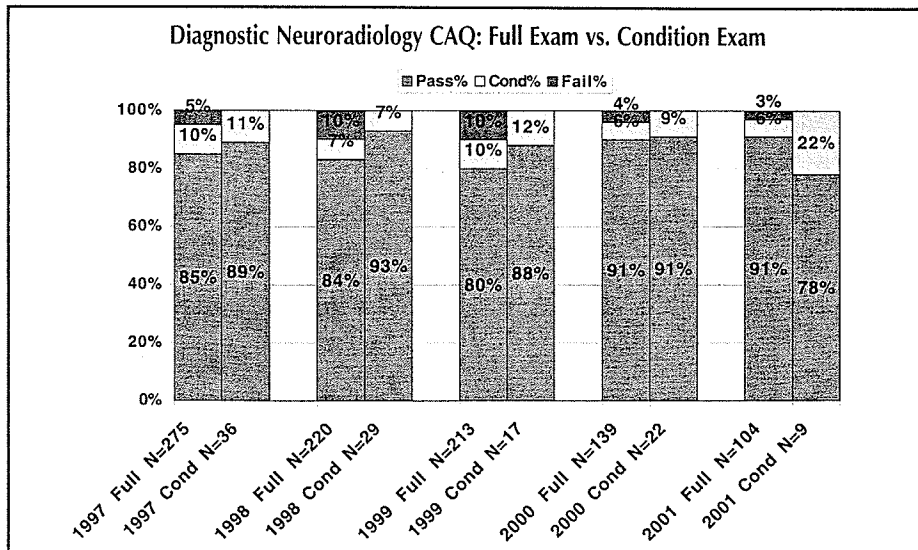

EXAMINATION STATISTICAL SUMMARY, CONTINUED...

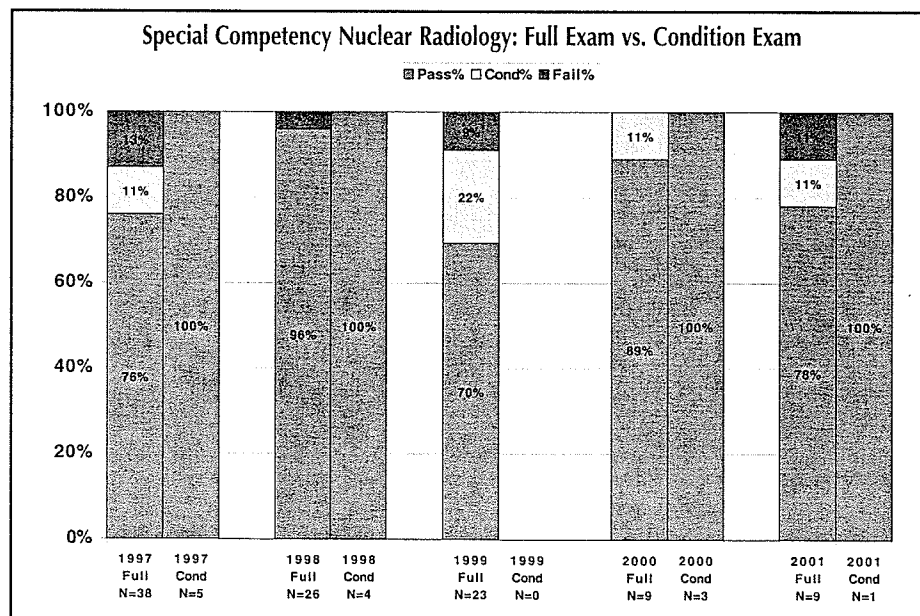
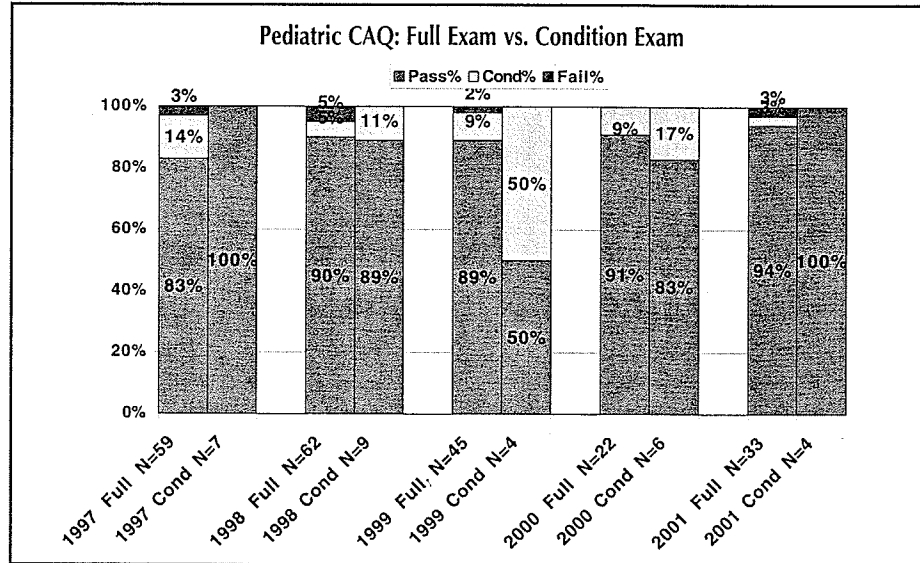

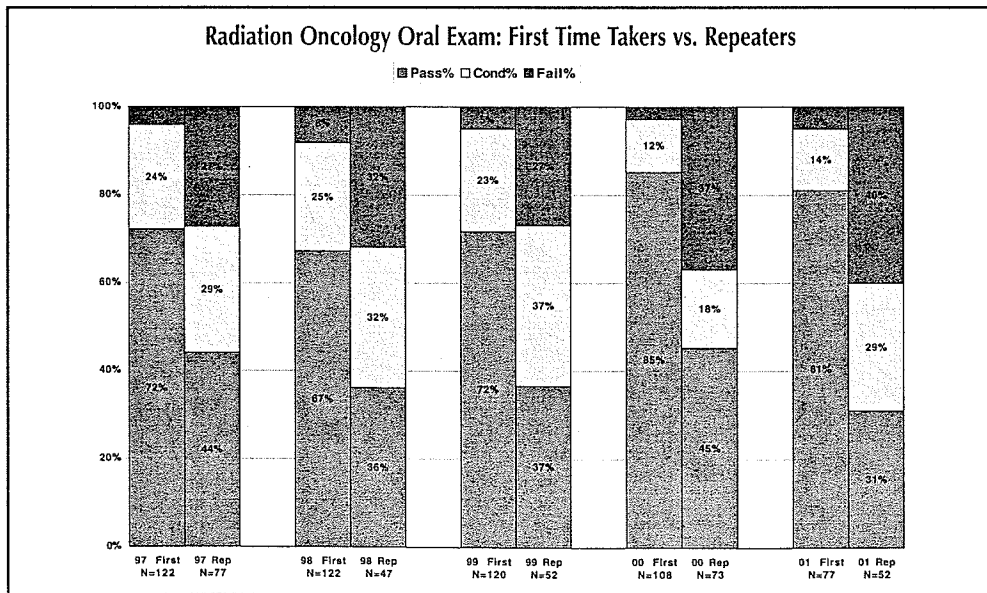
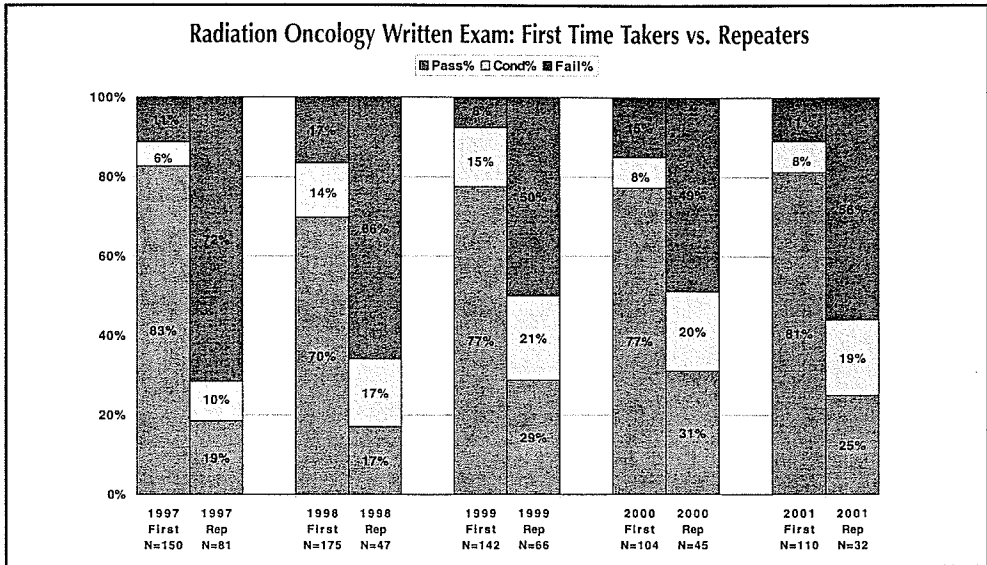

EXAMINATION STATISTICAL SUMMARY, CONTINUED...

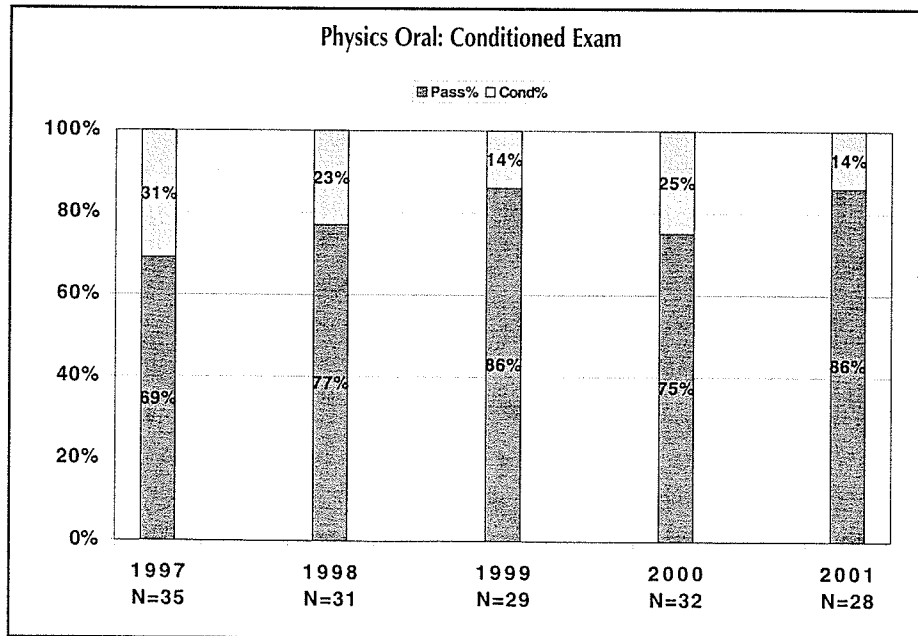
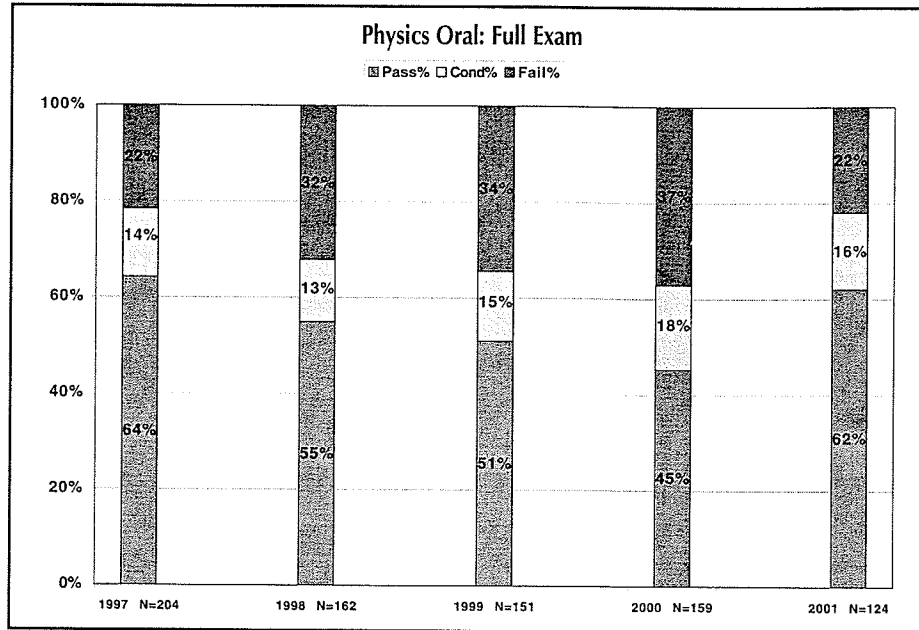

C HANGE OF ADDRESS NOTICE

Name _____

Previous Address	New Address
_____	_____
_____	_____
_____	_____

This is my home address office address

Home phone _____

Office phone _____

Fax _____

Mail to: American Board of Radiology
5441 E. Williams Blvd.
Suite 200
Tucson, AZ 85711

We welcome your comments.

2002–2003
SCHEDULE OF EXAMINATIONS

ORAL EXAMINATION

June 1–4, 2003

- Diagnostic Radiology
- Radiation Oncology
- Radiologic Physics

WRITTEN EXAMINATION

Sept. 12–13, 2002

- Diagnostic Radiology
- Radiation Oncology
- Radiologic Physics

CAQ EXAMINATION

Nov. 10–11, 2002

- Neuroradiology
- Vascular and Interventional Radiology
- Pediatric Radiology
- Special Competence in Nuclear Radiology

ORAL CONDITION EXAMINATIONS

Nov. 10–11, 2002

- Diagnostic Radiology
- Radiologic Physics

June 1–4, 2003

- Radiation Oncology

One Person's Reflections on the ABR Exam in Radiological Physics

The American Board of Radiology Board Exam in Radiological Physics was held on June 18, 1977 at Dallas (Southwestern Medical School). There were seven people taking the exam in Physics in a very large room that also had all of the people who are taking the Radiology Board Exams. There were probably about 40 or 50 of them also in the room. The room lighting is rather poor.

The exam consisted of two parts basically. In the morning there were 150 questions which were 3 types. First, there were multiple choice questions, possibly about 30 or 40 of them followed by about 50 or 60 true-false questions. However, each one of these true-false was of the multiple true-false variety in which 5 answers were given and each one had to be marked either true or false. So this meant that there were many, many more than 150 questions on this first part. In fact, even working as fast as possible I found that it was really impossible to complete the first part in the time allowed which was four hours.

We were supposed to be there at 8:00 in the morning. When the roll call was called there were 3 radiologists absent and it is standard procedure not to begin the exam until everyone is present. If they don't show up they have to wait until 8:50. So we had to sit around waiting until ten minutes to nine to begin. I understand the same thing has been the case for the past ten years. In any case we began at 8:50 and we were able to continue the first part of the exam til ten minutes to one. None of the people in Physics left before the four hours was up and in talking to them later everyone agreed that it was much too long and no one really could finish. I know in my case there were a number of rather ambiguous and difficult questions that I skipped over hoping to come back to them later at the end and I never did get back to them. There was really such a press for time.

Of these three types of questions, the true-false were by far the most difficult. One really didn't have time to think and analyse the situation carefully. One simply had to go as fast as possible, which meant in some cases that one was forced to make a guess. They were quite ambiguous.

Lets get back to the multiple choice questions. There were many types, such as basic general physics questions. Some questions involving medical terminology which I found to be rather difficult in some cases, other cases were pretty obvious. There were questions involving Nuclear Medicine, Diagnostic Radiology, and Radiation Therapy. Dosimetry was very heavily emphasized. The general physics questions were basically quite easy. One question involves a simple thing like throwing a ball up into the air with an initial velocity given; how far does it travel straight up? Another question was at what temperature do you have the same numerical value on both the Centigrade and Fahrenheit temperature scales? (-40°) One question involves a particle moving $6/10$ the speed of light and you were asked to figure out what was the ratio of the relativistic kinetic energy to the Newtonian kinetic energy. There were only a very few of general physics type questions this year. I understand that in past years there have quite a few of them.

Of course they were careful to give mixed units in these problems so that one had to be careful.

One type of question that I thought was very difficult involved a cross sectional cut through the body at the location of T-12 and we were asked a question about a number of organs and you had to tell which one the plane did not cut through. There were a number of medical questions. One involved different types of tumors-the sarcomas and other types-and you were asked to determine the type of tissue in which these tumors originated.

There were many questions on the exam having to do with the interaction of photons in matter. Much on photoelectric effect, Compton scattering, pair production. They asked about some of the fine points of interactions of radiation in matter.

There were quite a few questions on dosimetric techniques having to do with aspects of Bragg Gray cavity theory, of use of Victoreen chambers. One question asked to compare the kerma curve with the dose curve for infinitely thick media.

The nuclear medicine questions I thought were particularly difficult. Quite a few involved statistical considerations, e.g. Poisson, binomial, and normal distributions. There were a number of questions on radiobiology. You needed to know the names of the important people and to relate them to basic concepts, e.g. fraction, cell mitosis, etc.

In the multiple choice questions, a good bit of calculating was necessary to get the correct answers - most simple but time-consuming. Lots of questions on HVL, radioactive decay, etc. Question: A source decays at rate of 5% per hour. How long until it decays to 50% level?

At the end of the morning session, there were about 25 matching questions - these were probably the easiest to answer. Fairly basic concepts.

The second part of the exam began at 2:10 P.M. This session consisted of essay and problem questions. The number that you have to answer depends on whether you are taking the exam in Radiological Physics or one or two subfields only. Radiation Therapy & Diagnostic not too bad - Nuclear Medicine were very difficult I thought.

Here are some examples that I can recall. (Problems below are not exact, nor are they complete)

Therapy (4 given)

1. Three field plan in treatment. Dose rate in air given at isocenter. Use supplied TAR tables to determine dose rates at isocenter for each field. Then if times are all same what is it. Alternately if tumor doses are all to be the same, what should time be for each field? This is basically like a problem out of Johns book. What is total treatment times in each case, doses at d_{max} , etc. Compare the two plans.
2. Basic problems involving % depth doses. Also asked to determine separately primary and scatter contributions to dose. Tables of data, including zero area values, were supplied. Comment

on the use of zero area data.

3. General discussion & comparison of % depth dose, TAR, and TMR. Show how they are related, etc.
4. A problem involving radium in some rather odd geometrical shapes (disks, etc.) You had to determine exposure rates, I believe. (I skipped this one)

Therapy Protection (2 given)

Calculate dose from internally administered fictitious isotope. Nuclear data supplied. You had to go through the whole business but not too bad.

(I do not recall the second problem.)

Diagnosis (4 given)

1. Compare xeroradiography with film-screen and no screen systems for mammography. Discuss M_0 vs W anodes, Al vs M_0 filters, etc. Discuss entrance skin doses, image formation methods, etc.
2. Describe the slit method for carrying out a measurement of the MTF, give math involved, and discuss.
3. Cine problem involving overframing, etc. Several parts in this question not recalled. Also compare calcium tungstate with rare earth screens.
4. Discuss the sources of, and contributions to, noise in the radiographic image. (had several other parts)

Diagnosis Protection (2 given)

1. Room layout given for a 125 kVp radiographic tube. Workload given, make assumptions and calculate barrier thicknesses for the room, etc.

Nuclear Medicine (4 given)

1. Cal. flux density from a 1 mc ^{99m}Tc source at 1 & 5 cm. Then compute the exposure rate constant. Calculate the activity needed to deliver 8000 rads from ^{131}I to thyroid. Table of data supplied. Calculate % uptake and error in a ^{131}I situation.
2. Give full description of ^{59}Fe - Ga red cell volume (dual isotope) procedure and the ferrokinetics involved. Discuss origins of various peaks that appear in spectra (photopeak, escape peaks, etc.).
3. There was a problem involving scanning of a tumor and you were asked about the statistical evaluation of the scan. I do not recall the details on this problem. (It was one I skipped.)
4. There was a problem on: How do you do an absolute calibration of a ^{99m}Tc source?

Nuclear Medicine Protection

1. Calculation involving the dosimetry of internally administered isotopes. (A lot of emphasis on the exam seemed to be placed on this type of calculation).

This is a summary of some questions and statements about the ABR written exam which was given on June 18, 1977.

Morning Session Part I

(About 450)

This session consisted of a large number of true-false, multiple choice, and matching questions which dealt with basic radiological physics, ultrasound, anatomy and physiology, radiation protection, thermodynamics, and other miscellaneous topics in medical physics. It is hard to remember too many specific questions about this session. In general, I thought that the anatomy ^{and} ~~in~~ physiology were slightly difficult. The basic physics was moderately easy and the many short and specific problems which ~~made it to~~ ^{were to} be worked did require ^{the} use of a hand calculator for simple mathematics solutions. I believe it to be very important to budget time very carefully in this session in order to finish all of the questions on time. Many of these questions could be answered in just little more time than it takes to read the question carefully. However, a few did require a little scratch paper mathematical analysis in order to solve. The anatomy ^{and} ~~in~~ physiology did seem to be more difficult to me but as a physicist I felt inadequately prepared for some of the detailed questions in those ^{two} ~~3~~ areas. I would definitely recommend a couple of weeks study in those ~~3~~ areas before taking this exam unless a person felt that his background was adequate already.

Afternoon session Part II

This session consist of specific problems in the field which I chose, therapeutic radiological physics. I can remember in fairly good detail all of the problems which were on this Part II of the exam.

Problem 1. This problem consisted of a straightforward isocentric treatment plan for a cobalt 60 machine. Three rectangular ports, each of different size spaced 120° apart, were aimed at a point in tissue which was not the center of symmetry of the transverse plane anatomical section. Enough tabulated data was given in the form of a tissue air ratio table and a table of equivalent squares of rectangular fields and the necessary machine parameters like the isocentric output dose rate and other miscellaneous factors were given. One was asked to find (a) the treatment times for equal dose contributed per field at the tumor site (b) treatment time for a total of 180 rads per session each port being treated for the same time and (c) the maximum doses at maximum buildup in tissue was to be computed in each case.

Problem 2. This problem consisted of a calculation of the scattered radiation component at a certain depth d in tissue for a certain beam size. Actually what was given was a percent depth dose table which included the "0" area column in addition to other square field columns. One was asked to compute the primary and scattered dose fractions at a certain depth in tissue for a certain beam size. Of course, this makes use of the "0" area data in addition to the percent depth dose data for the given beam size. After that was done the question continued in an examination of how "0" depth data is measured or obtained experimentally for a given treatment machine and to list as many uses as one could think of for this type of data.

Problem 3. This problem consisted of an analysis of the dose rate due to a uniformly radioactive disc of radium 226 in equilibrium with its decay

products and a ring also with uniform activity per unit length. The disc and ring each contained the same number of milligrams of radium with the same filtration. One was asked to calculate or estimate the ratio of the dose rate produced by the ring divided by the dose rate produced by the disc along the central axis of each source. Also when this was finished the lateral dose rate ratio distribution was to be plotted or calculated. This problem of course is an example of the basic philosophy of the ^{Quimby -} ~~Quimby~~ Patterson Parker radium systems where in my opinion is illustrated only to point out the differences in the 2 systems.

example
Problem 4. This problem consisted of an isotope protection, a specified dose of an isotope having 2 beta emissions is given to a particular patient. The beta maximum energies and percentages are given, also the half life and the dosage in curies per kilogram. The organ uptake percentage is given and one is asked to calculate the organ dose rate and total dose for the decay of the isotope. After this is done, there are several other questions that involve the kind of assumptions that are made in this type of calculation and an estimation of the error caused by these assumptions.

Problem 5. This was also a protection problem which involved the design of the primary and secondary wall thicknesses for a certain cobalt 60 treatment room. The room plan layout was given, also the ^{workload} ~~workload~~ per week for the particular therapy ^{patient} load was given. The necessary information for concrete ^{10th value} ~~10 value~~ thickness and such information was also given. This problem seemed to be a straightforward room shielding type problem which involved the calculation of concrete thickness both in the primary beam and at several other selected points in the scatter beam regions. It appeared to be fairly long and tedious but otherwise fairly straightforward.

As I said at the beginning, I do feel that the test was fairly straightforward, certainly in the physics areas, and not too difficult overall except at the morning session, ^{which} ~~possibly~~ was long for the time allotted for its completion. The afternoon session could be completed early so that one could go over answers ~~in great detail~~ and still not exceed the time allotted. Perhaps the afternoon session seemed fairly easy since it dealt more specifically with the type of work which is routinely carried on in therapeutic radiological physics.

LHD:fz

Reference your letter of 25 July 77 regarding input to aid members of TRMP in preparation for their ABR examinations in Radiological Physics, I would like to provide the following advice to those preparing for the written examination.

The first portion of the examination is basically a high volume quick response multiple choice, multiple true false examination. There is insufficient time to reason through most questions. It is, therefore, necessary to study for quick recall of a large volume of facts, formulas, and information. There is very little opportunity to return to any questions which are skipped. One is well advised to keep a close watch on time. It is permissible to return to any question or page within the first part until the papers are turned in.

One matching question is recalled where in the transverse slice of computerized tomographic scanner was stated and a list of organs given which might be experienced in the normal anatomy at that level.

Both sections of the 1977 examination were heavily weighted toward radiation protection for diagnostic and therapeutic x-ray. Although tables, graphs, and charts were provided, the necessity to recall the exact form of each of the formulas in NCRP report #49 was totally unexpected. If this format is to be continued, it may be expected that reference material where one would customarily seek the equation and the accompanying table, chart, or graph concurrently may be separated and the candidate required to recall the equations independently.

The second portion of the examination was composed of questions any one of which could have required 1-1½ hours to complete. Although the questions were not especially difficult, value judgments, calculations, and a large



volume of writing can be expected. One would be well advised to take at least six sharpened pencils for this portion. In general, it might be said that the examination tests rapidity of recall, rapidity of action, and stamina more than specific data.

I hope you will find the above information of some value in the preparation of your document.

Jerome F. Wiot, M.D.
Cincinnati, Ohio
President

Luther W. Brady, M.D.
Philadelphia, Pennsylvania
Vice President

Kenneth L. Krabbenhoft, M.D.
Detroit, Michigan
Secretary

M. Paul Capp, M.D.
Tucson, Arizona
Treasurer

James H. Christie, M.D.
Albuquerque, New Mexico

Lawrence W. Davis, M.D.
Philadelphia, Pennsylvania

Juan A. del Regato, M.D.
Tampa, Florida

Jack Edeiken, M.D.
Philadelphia, Pennsylvania

Milton Elkin, M.D.
New York, New York

The American Board of Radiology

COMMITTEE ON RADIOLOGICAL PHYSICS
Jack S. Krohmer, Ph.D., Chairman

UNIVERSITY HEALTH CENTER
4201 ST. ANTOINE
DETROIT, MICHIGAN 48201

PHONE (313) 577-5077
(313) 494-4742

Theodore E. Keats, M.D.
Charlottesville, Virginia

Eugene C. Klatter, M.D.
Indianapolis, Indiana

Jack S. Krohmer, Ph.D.
Detroit, Michigan

Richard G. Lester, M.D.
Houston, Texas

Seymour H. Levitt, M.D.
Minneapolis, Minnesota

Robert W. McConnell, M.D.
Houston, Texas

Thomas F. Meaney, M.D.
Cleveland, Ohio

Robert G. Parker, M.D.
Los Angeles, California

William E. Powers, M.D.
Detroit, Michigan

Paul A. Riemenschneider, M.D.
Santa Barbara, California

Lee F. Rogers, M.D.
Chicago, Illinois

The attached material is a set of sample questions from previous American Board of Radiology written examinations for physicists. You will note that there are a group of questions from Part I of the examination which includes three types of questions as follows:

A-type Single best answer out of four or five choices.

X-type Multiple true or false answers. Any answer can be either true or false.

B-type Usual matching type of question. Any of the five answers can be correct for each of the four questions.

Performance characteristics of the question are stated for each question. The "p" value indicates the percentage of correct answers for all takers. The "r" value is a measure of the discriminating ability of the question as evaluated by the upper 10% of takers compared to the lower 10% of takers. Upper and lower 10% is determined by grade on the overall examination.

There are several questions from the Part II examination in the three fields: Therapeutic Radiological Physics, Diagnostic Radiological Physics, and Medical Nuclear Physics.

It should be noted that these are actual questions which were used on previous examinations. They will not be used in the future. These questions are being supplied simply to acquaint prospective candidates with the structure and level of difficulty of previous examinations. No change in structure or degree of difficulty is anticipated in future examinations.

Type A

For a nuclide X with the decay scheme

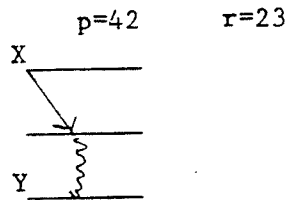

How many gamma rays are emitted per 100 disintegrations of X, if the coefficient for internal conversion is 0.25%

- A. 65
- B. 70
- C. 75
- D. 80
- E. 85

Type X

The velocity of sound in air is:

p=28 r=37

- A. not dependent on wavelength
- B. generally independent of pressure
- C. proportion to the square root of the absolute temperature
- D. proportional to the square root of the absolute temperature
- E. dependent on the square of the frequency

Type B

- 1) p=80 r=38
- 2) p=65 r=67
- 3) p=64 r=62
- 4) p=77 r=46

A 200 pound man is standing on a spring operated scale in an elevator. Match the conditions 1-4 with the scale readings A-E. (Scale readings A-E may be used more than once.)

- | | |
|--|---------------|
| 1. Elevator at rest | A. Zero |
| 2. Elevator accelerated upward at 32 ft/sec ² | B. 100 pounds |
| 3. Elevator descending at 32 ft/sec | C. 200 pounds |
| 4. Elevator falling freely | D. 300 pounds |
| | E. 400 pounds |

Type A

In order to produce an Al-27 compound nucleus with an excitation energy of 30.0 MeV, what projectile energy is required for the process $^{25}\text{Mg}(d, \text{---})^{27}\text{Al}^*$ where the asterisk denotes an excited nuclear energy state.

p=54 4=44

DATA:	^{27}Al	26.989amu
	^{25}Mg	24.9938amu
	^1H	1.008123amu
	^2H	2.014708amu
	931-meV =	1 amu

- A. 12.35 MeV
- B. 17.65 MeV
- C. 32.65 MeV
- D. 47.32 MeV
- E. 3764 MeV

Type X

p=83 r=12

Indicate which of the following statements concerning electron capture is/are true:

- A. May occur when the energy levels of the parent and daughter nuclei differ by less than 1.02 MeV.
- B. Is accompanied by emission of a neutrino.
- C. May have gamma-ray emission associated with it.
- D. May have characteristic x-rays associated with it.
- E. May have Auger electrons associated with it.

Type A

p=60 r=40

The dose per millicurie to the empty gallbladder (mass 10g, absorbed fraction 0.022) is 9 rads for ^{99m}Tc . With the kinetics assumed to be identical, what is the dose per millicurie to the gallbladder plus contents (mass 70g, absorbed fraction 0.066) for ^{99m}Tc ?

- A. 1.3 rads
- B. 3.9 rads
- C. 9 rads
- D. 63 rads
- E. 189 rads

Type X

p=81 r=23

Which of the following enters into the computation of the exposure rate constant (T_{∞}) for a radioactive nuclide?

- A. The energy (E_i) of photons emitted by the nuclide.
- B. The mass attenuation coefficient (μ/p) for photons of energy (E_i) in tissue.
- C. The fractional emission (n_i) of photons from the nuclide.
- D. The f-factor for photons of energy (E_i) in air.
- E. The mass energy absorption coefficient (μ_{en}/p) of air for photons of energy E_i .

Type A

p=38 r=35

If the rate of decay for a single radionuclide is plotted logarithmically as a function of time (i.e., $\log_{10}dN/dt$ vs. t), the slope of the line will be:

- A. $\lambda/303$
- B. -2.303λ
- C. $-\lambda$
- D. $2.303/\lambda$
- E. 2.303

Type B

p=	1) 83	r=	20
	2) 83		6
	3) 66		40
	4) 60		26

The radioactive nuclide A_ZX can spontaneously disintegrate by several modes of decay. For each of the modes of decay (1-4), select the most appropriate decay product nuclide (a-e).

- | | | | | |
|------------------------|----|-----------------------|----|-----------------------|
| 1. Gamma Emission | a) | $A-1$
X
$Z-1$ | d) | A
X
$Z+1$ |
| 2. Positron Decay | | | | |
| 3. Electron Capture | b) | A
X
Z | e) | $A+1$
X
$Z+1$ |
| 4. Internal Conversion | | | | |
| | c) | A
X
$Z-1$ | | |

Type A

A beam of 100 keV photons with a 1×10^{10} photons/cm² is incident upon a thin absorber. If 1% of the photons interact in the absorber and the mass energy absorption coefficient is 0.1 cm²/g and the total mass attenuation coefficient is 0.2 cm²/g, how much energy is absorbed by 1 cm² of the absorber?

- A. 1×10^8 keV
B. 5×10^8 keV
C. 1×10^9 keV
D. 5×10^9 keV
E. 1×10^{10} keV

Type X

Which of the following statements is/are true concerning the interaction of x- or gamma-ray photons with matter?

- A. For any Z, the Compton effect predominates for photon energies between 0.8 and 3 MeV.
B. For low Z materials, the Compton effect predominates over a much wider range of energies than 0.8 to 3 MeV.
C. For any Z, the photoelectric effect is dominant below 0.8 MeV.
D. For any Z, the pair production effect is dominant at energies greater than 4 MeV.
E. For very high Z materials, the pair production effect becomes dominant at energies below 4 MeV.

Type A

p=90 r=20

One cm of a material reduces the intensity of a collimated beam of gamma rays by a factor of 2. What is the photon mean free path?

- A. 0.34 cm
- B. 0.69 cm
- C. 1.00 cm
- D. 1.44 cm
- E. 2.88 cm

Type X

p=79 r=23

If 1 rad is the uniform dose to 10 gram (g) of unit density tissue, 5g of this tissue receive

- A. 0.5 rad
- B. 1.0 rad
- C. 2.0 rad
- D. 5 g rad
- E. 10 g rad

Type X

p=47 r=20

The gray is the special name in the SI system of units for which of the following:

- A. Specific energy imparted
- B. Absorbed dose
- C. Dose equivalent
- D. Absorbed dose index
- E. Kerma

Type A

p=50 4=8

Two similar phantoms are treated with radiation having different HVLs (half-value layers). If the entrance dose is the same for both phantoms but the exit dose is lower for one phantom, then the integral dose would be:

- A. About the same for both phantoms
- B. Greater for the phantom with the higher exit dose
- C. Greater for the phantom with the lower exit dose
- D. Dependent upon dose rate (rads/min)
- E. Dependent upon SSD (source-skin distance)

Type X

p=67 r=29

A thin pencil beam of ^{60}Co gamma rays is incident upon a mass of water thick enough to absorb essentially all of the incident energy.

- A. The area under the kerma curve and the absorbed energy curve as a function of depth to infinity is the same.
- B. The kerma curve shows a build-up point just like the absorbed dose curve.
- C. The point of maximum build-up on the absorbed dose curve will occur at approximately 1.0 cm depth.
- D. The kerma curve and the absorbed dose curve are parallel at several cm depth in the phantom.
- E. The absorbed dose curve will lie slightly above the kerma curve at several cm depth in the phantom.

Type A

p=42 r=38

Under ideal conditions, an ionization chamber containing one gram of air is exposed to a uniform flux density of gamma rays. With air wall equivalence, how much charge is collected from the chamber when it is exposed to one roentgen?

- A. 2.58×10^{-3} C
- B. 2.58×10^{-4} C
- C. 2.58×10^{-5} C
- D. 2.58×10^{-6} C
- E. 2.58×10^{-7} C

Type X

p=67 r=45

The line source used in measuring a modulation transfer function:

- A. Should have a sinusoidal structure
- B. Should have a uniform linear activity
- C. Should have a width at least 10 times less than the reciprocal of the highest resolvable frequency of the system being measured
- D. Can have internal structure, but only over a region less than 1/10 of the reciprocal of the highest resolvable frequency of the system being measured
- E. Should have a length no more than twice its width

Type X

p=76 r=38

On a volume basis a silicon detector is more sensitive than an air ionization chamber because:

- A. The atomic number is higher
- B. The polarizing potential is higher
- C. The density is greater
- D. W is lower
- E. It must be cooled

Type A

p=60 r=27

With only a few exceptions, the slopes (D_0) of the straight line portion of x-ray survival curves for mammal cells cultured "in vitro" falls between:

- A. 50 to 100 rads
- B. 100 to 200 rads
- C. 200 to 300 rads
- D. 300 to 400 rads
- E. 400 to 500 rads

Type A

p=81 r=38

The part of the cell cycle during which chromosomes are visible is:

- A. T
- B. M
- C. S
- D. G_1
- E. R

Type X

p=72

r=35

The oxygen enhancement ratio:

- A. is greater for photon beams than for neutron beams.
- B. Is important in deciding a fractionation schedule.
- C. May explain the failure to control some tumors by radiotherapy.
- D. Shows that oxygen is a sensitizing agent in the biological effect of radiation.
- E. Can be determined by cell survival studies.

Type A

p=50

r=23

A compound with an infinite biological half life in a particular organ may be labeled with one of two radionuclides A or B, each of which emits a single photon. Compared to A:

the absorbed dose constant for B is twice as great

the absorbed fraction for B is twice as great

the physical half life for B is half as great

For equal concentration of the radionuclides in the organ, the penetrating component of the radiation dose from B compared to A would be:

- A. four times greater
- B. Twice as great
- C. the same

Type X

p=65

r=29

Tritium contamination may be measured by:

- A. a gas-flow ionization chamber
- B. an end-window Geiger counter
- C. a sodium-iodide scintillation counter
- D. a gas-flow proportional counter
- E. a liquid scintillation counter

Type B

p=64

r=29

Match the following protection requirements with dose equivalent value.

- | | |
|--------------------------------------|---|
| 1. Control of area required | A. <2 mrem in an hour and <100 mrem in any 7 consecutive days |
| 2. Radiation area sign required | B. >2 mrem in an hour or >100 mrem in any 7 consecutive days |
| 3. Unrestricted area | C. >5 mrem in an hour to major portion of body |
| 4. High radiation area sign required | D. >100 mrem in 1 hour to major portion of body |

Type A

p=88 r=15

It is customary to use the notation y_1, y_2, \dots, y_m for measurements y in a sample of size m drawn from a population n . The mean of the sample measurements is:

A. not calculable from the description given

$$B. \bar{y} = \frac{1}{n} \sum_{i=1}^m y_i$$

$$C. \bar{y} = \frac{1}{i} \sum_{i=1}^m y_i$$

$$D. \bar{y} = \frac{1}{m} \sum_{i=1}^m y_i$$

$$E. \bar{y} = \frac{1}{i} \sum_{i=1}^{n_i} y_i$$

Type A

p=46 r=31

A promising new mode of therapy shows that 79 of a total of 121 patients get an excellent response, i.e., go three years disease-free. The 95% confidence interval estimate for p , the probability that a patient will remain disease-free, is equal to:

A. .20 to .40

B. .30 to .90

C. .50 to .60

D. .57 to .74

E. .90 to .95

Type A

p=65 r=54

The number of counts required to achieve a 0.1% standard error in percent of the mean at the 68.3% confidence level is:

A. 1,000

B. 10,000

C. 100,000

D. 1,000,000

E. 10,000,000

Type A

p=80 r=13

Indicate which is the correct sequence of the path of excretory wastes in man from the body to the outside.

A. Bladder, blood, kidney, ureter, urethra

B. Blood, kidney, urethra, bladder, ureter

C. Blood, bladder, urethra, kidney, ureter

D. Blood, kidney, ureter, bladder, urethra

E. Blood, bladder, ureter, kidney, urethra

Type A

p=85 r=15

Which of the following tissues is the most radiosensitive?

A. CNS (brain)

B. Cardiac

C. Skeletal

D. Thyroid

E. Hemopoietic

Type A

p=63 r=73

The plasma protein which is coagulated by the enzyme thrombin to produce a blood clot is:

- A. Albumin
- B. Fibrinogen
- C. Prothrombin
- D. Hemoglobin
- E. Ferritin

Type B

Match the following terms A-E with the definitions 1-4:

- | | |
|---------------------|---|
| A. Atrophy | 1. Irregularity of muscular action |
| B. Atelectasis | 2. A dilated artery or vein sac |
| C. Ataxia | 3. Collapse of a lung |
| D. Artherosclerosis | 4. Arterial lesions containing cholesterol deposits |
| E. Aneurysm | |

Type B

p=73 r=38

For each numbered term 1-4, match the most closely associated anatomic region A-E.

- | | |
|---------------|-------------------|
| A. Brain | 1. Hydronephrosis |
| B. Bone | 2. Osteoporosis |
| C. Kidney .40 | 3. Hydrocephalous |
| D. Joints .90 | 4. Arthritis |
| E. Liver | |

1979

TYRUX A

11. One cm of a material reduces the intensity of a collimated beam of gamma rays. What is the photon mean free path?

- a) 0.34 cm
- b) 0.69 cm
- c) 1.00 cm
- d) 1.44 cm
- e) 2.88 cm

$P = 90$
 $n = 20$

12. If 1 rad is the uniform dose to 10 gram (g) of unit density tissue, 5 g of this tissue received

- A. 0.5 rad
- B. 1.0 rad
- C. 2.0 rad
- D. 5 g rad
- E. 10 g rad

1977 TYRUX

$P = 79$
 $n = 23$

120 65. The gray is the special name in the SI system of units for which of the following:

- a) Specific energy imparted
- b) Absorbed dose
- c) Dose equivalent
- d) Absorbed dose index
- e) Kerma

1979 TYRUX

$P = 47$
 $n = 20$

T-3. Given the loop and disc of radius shown, if the loop (l), and disc (d) are of the same diameter (A) and have the same total radium loading, explain

- Why the ratio of the dose rates D_l/D_d is equal, greater or less than unity.
- How D_l/D_d behaves as "h" varies.
- How the dose distribution varies in a plane parallel to the loop and to the disc as a function of h.

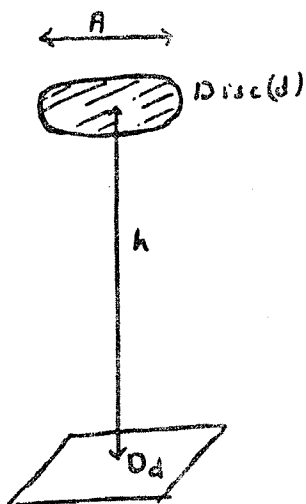
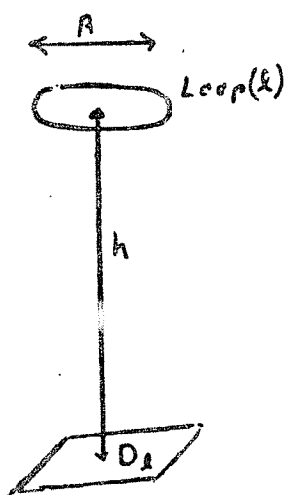

Problem 1

Part A:

A 4 MV x-ray beam is calibrated at 5 cm depth in a water phantom with a carbon wall ionization chamber of equilibrium thickness for ^{60}Co . The chamber has a volume V and a calibration factor of 6×10^6 R/coulomb for ^{60}Co . Stating all assumptions necessary at each step, rigorously derive a relationship between the reading R of the chamber and the dose D_{med} to the medium at 5 cm depth, using the approximation wherever necessary that the chamber wall is similar to the water medium. Simple substitution of C_{λ} is not an appropriate derivation; instead, the relationship between D_{med} and R must be derived in terms of mass stopping power ratios, mass energy absorption coefficients, etc.

Part B:

From the relationship derived in Part A and from data in Table 2, estimate the dose in water for a reading of 2.6×10^{-5} coulombs.

<u>TABLE 2</u>	
$f = 0.957$	$S_{\text{air}}^{\text{carbon}} (^{60}\text{Co}) = 1.010$
$A_C = A_{\text{eq}} = 0.985$	$S_{\text{air}}^{\text{carbon}} (4 \text{ MV x rays}) = 1.002$

Problem 2

(4)

Part A:

In figures (a) and (b) below, phantoms of two different shapes are irradiated with ^{60}Co fields of $10 \times 10 \text{ cm}^2$ area defined at points P_a and P_b . Points P_a and P_b are at depths of 10 cm each and are at the calibration distance from the source. The calibration dose rate in air is 100 rads/minute. With TARs from the attached Table³ calculate the dose rates at points P_a and P_b .

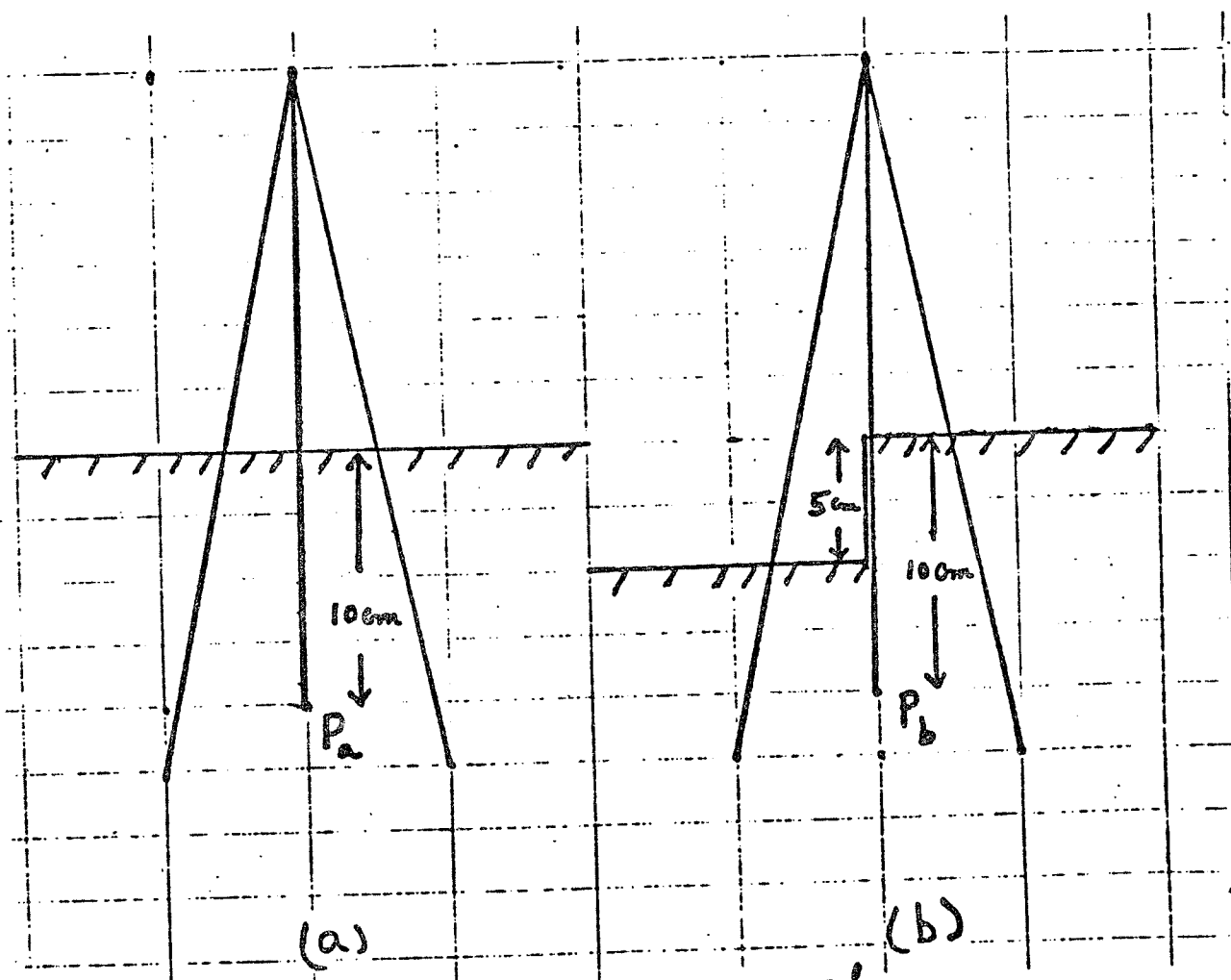

Table B-2, Johns supplied

Table 2d (Cont) Tissue-Air Ratios for Cobalt 60

d (cm)	8x15	8x20	10x10	10x15	10x20	12x12	15x15	15x20	20x20	20x30	25x25	30x30	35x35
0.5	1.037	1.041	1.035	1.042	1.046	1.041	1.051	1.056	1.063	1.071	1.073	1.080	1.084
1	1.032	1.035	1.031	1.038	1.043	1.036	1.048	1.054	1.062	1.069	1.072	1.079	1.084
2	1.005	1.009	1.004	1.013	1.018	1.014	1.025	1.032	1.040	1.049	1.052	1.059	1.065
3	.975	.980	.974	.985	.990	.985	.999	1.006	1.016	1.026	1.029	1.038	1.044
4	.942	.947	.940	.952	.959	.953	.968	.977	.987	.999	1.002	1.014	1.021
5	.907	.913	.905	.918	.925	.919	.936	.946	.957	.971	.974	.988	.996
6	.860	.876	.867	.882	.890	.883	.902	.912	.925	.940	.944	.959	.970
7	.830	.837	.827	.844	.853	.845	.866	.878	.893	.909	.913	.929	.941
8	.790	.798	.787	.805	.815	.806	.830	.843	.859	.877	.881	.899	.912
9	.751	.760	.747	.767	.778	.768	.793	.808	.825	.845	.849	.869	.882
10	.713	.722	.709	.729	.741	.730	.756	.771	.790	.811	.816	.837	.852
11	.675	.685	.672	.692	.704	.692	.719	.736	.755	.777	.782	.803	.820
12	.640	.650	.636	.657	.670	.658	.685	.702	.722	.744	.750	.772	.790
13	.607	.618	.603	.625	.638	.626	.653	.670	.690	.713	.720	.743	.762
14	.575	.586	.571	.593	.606	.594	.622	.639	.660	.684	.691	.715	.734
15	.545	.556	.540	.563	.576	.563	.593	.610	.633	.656	.662	.687	.706
16	.516	.527	.510	.533	.547	.533	.564	.582	.605	.628	.634	.660	.679
17	.488	.499	.483	.506	.519	.506	.536	.554	.577	.601	.608	.633	.653
18	.462	.474	.457	.479	.493	.479	.509	.528	.551	.575	.582	.607	.627
19	.438	.449	.433	.455	.469	.455	.485	.503	.526	.550	.557	.583	.603
20	.415	.426	.410	.431	.445	.431	.461	.479	.502	.527	.534	.560	.580
22	.369	.380	.364	.385	.399	.384	.413	.431	.456	.481	.488	.515	.535
24	.329	.340	.324	.345	.358	.345	.373	.390	.412	.438	.445	.471	.492
26	.294	.304	.290	.309	.322	.309	.336	.352	.373	.398	.405	.431	.451
28	.263	.270	.257	.276	.288	.276	.302	.320	.339	.362	.368	.393	.413
30	.233	.242	.228	.245	.257	.244	.268	.286	.305	.328	.335	.358	.377

* This entry is also the backscatter factor.

1978
PART II
THERAPY

35

nts

Problem 2

4)

Part B:

A transit dose measuring device installed in a ⁶⁰Co unit is used to correct the tumor dose for body inhomogeneities. Two opposing 10 x 10 cm fields are used at SSD 80 cm to treat the thorax of a patient of actual thickness 24 cm. The transit dose measuring device showed that the patient transmitted 32% of the radiation. With the attached tables 4-6, calculate the tumor dose for a given dose of 150 rads to each of the fields, assuming that the tumor is near the center of the patient:

- (i) Assuming unit density tissue.
- (ii) Taking into account inhomogeneities.

Circle the data in the tables you used in solving the problem.

(2)

Part C:

In Part B, why is the assumption necessary that the tumor is located near the center of the patient?

Table B-8, Johns supplied

TABLE 5

TABLE X-6
PARAMETERS USEFUL IN CORRECTING ISODOSE PATTERNS FOR AIR GAPS

Radiation	SSD (cm)	Absorption per cm	Isodose Shift (air gap is h cm)
HVL-2 mm Cu	80	10.5%	0.7 h
HVL-4 mm Cu	80	8.5%	0.7 h
Co-137	85	5.5%	0.4 h
Co-60	80	5.0%	0.67 h
4 Mv	100	4.0%	0.65 h
25 Mv	100	2.0%	1.0 h

TABLE 6

TABLE XII-5
PER CENT OF A COBALT 60 BEAM TRANSMITTED THROUGH A UNIT DENSITY PHANTOM
MEASURED UNDER CONDITIONS OF NO SCATTER
(Courtesy Brit J Radiol (5))

Thickness cm	% Trans.	Thickness cm	% Trans.	Thickness cm	% Trans.
12	48.0	20	28.1	28	16.7
14	41.4	22	24.6	30	14.7
16	36.2	24	21.6	32	12.9
18	32.0	26	19.0	34	11.4

oints

Problem 3

(6)

Part A:

Suppose one has a 20 x 20 cm beam of 20 MeV electrons striking a water phantom. With bone density = 1.5 g/cm^3 and lung density = 0.5 g/cm^3 , how far and in what direction would you estimate the 50% isodose line would shift if:

- (i) A one cm thick slab of bone were to replace the water between 1 and 2 cm depth?
- (ii) A one cm thick slab of bone were to replace the water between 10 and 11 cm depth?
- (iii) A two cm thick slab of lung were to replace the water between 1 and 3 cm depth.
- (iv) A two cm thick slab of lung were to replace the water between 10 and 12 cm depth?

(4)

Part B:

On the attached graph, draw the isodose distribution as accurately as you can for the 5, 50% and 90% isodose curves for electrons.

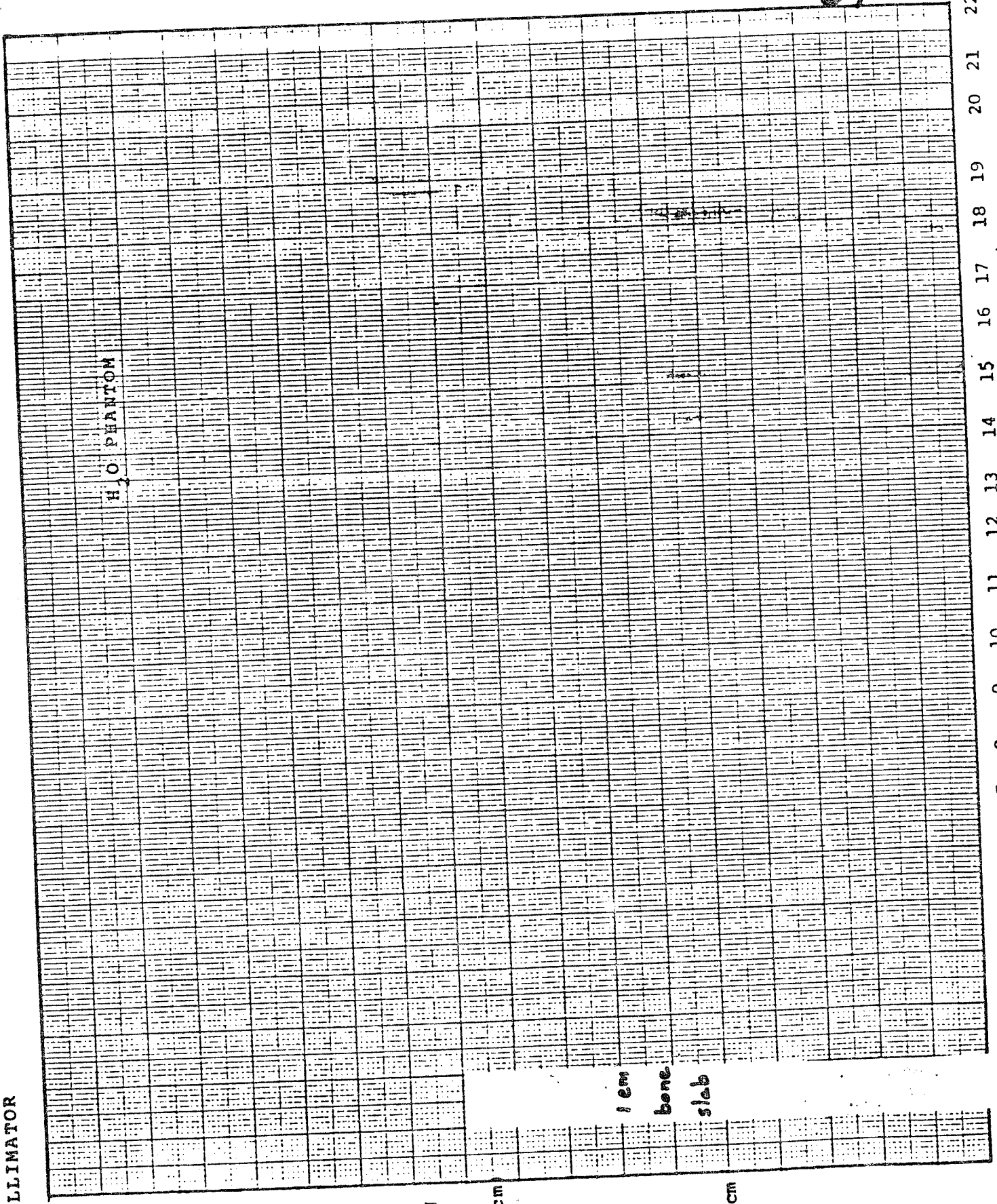

COLLIMATOR

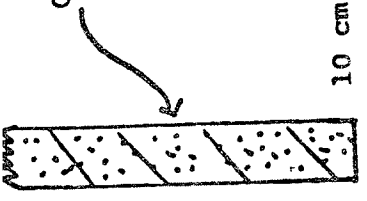

20 MeV
ELECTRON
BEAM



(20 x 20cm)



-10 cm



0

1

2

3

4

5

6

7

8

9

10

11

12

13

14

15

16

17

18

19

20

21

22

THE AMERICAN BOARD OF RADIOLOGY
1979 RADIOLOGICAL PHYSICS EXAMINATION: PART II

T-1

- pts. a) A treatment of the lower back is to be given at a source to skin distance of 135 cm. The beam size is 25 x 25 cm at this distance. A cylindrical lead block is used to shield a kidney and produces a shielded region 8 cm in diameter. Estimate the dose to the kidney at a depth of 5 cm and its relation to the dose in the open, unshielded portion of the field. The dose rate in free space at a distance of 80.5 cm is 60 rad/min, the radiation is from Cobalt 60. Assume the shielding block is thick enough to eliminate the primary beam so that only scattered radiation reaches the kidney.
- b) The arrangement of fields shown in Figure 6 is used to treat a tumor midway between the AP fields which are separated by 16 cm. The tumor is symmetrically situated between the oblique fields which are 20 cm apart. Cobalt 60 radiation at SSD 80 cm and field size 6 x 20 cm are used (See Table 3).
- pts. 1. Assuming each field receives the same given dose, find this given dose to yield a total tumor dose of 6000 rad. Calculate the dose at a point 0.5 cm below skin under the AP and the oblique fields.
- pts. 2. What given dose should each field receive so that the dose to the tumor from each of the fields is the same and the total tumor dose is 6000 rad? Calculate the dose at a depth of 0.5 cm below the skin for the AP and oblique fields.

$SAR + TAR_1 + \%DD$
Tables for Co-60
from Johns supplied

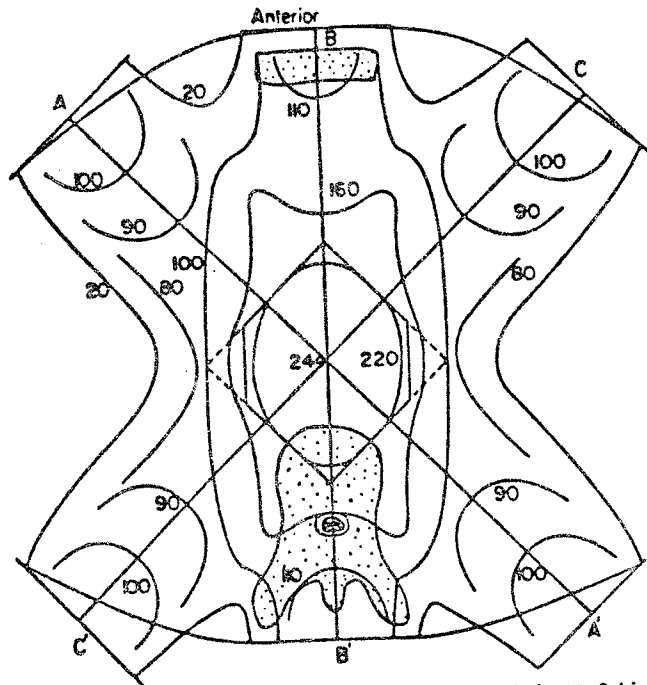

Isodose curves resulting from six 6 x 20cm cobalt 60 fields at SSD 80 cm arranged to treat the oesophagus.

Figure 6.

a)

pts.

1) Discuss a method for the energy calibration of electron beams. Include in your discussion both the theory upon which this method is based and the practical aspects of making such measurements in the field.

pts.

2) Discuss a method for the output calibration of electron beams. Include in your discussion both the theory upon which this method is based and the practical aspects of making such measurements in the field.

pts.

b) It is desired to treat a cancer of the tongue to 6000 rad in 8 days using a cylindrical volume radium implant with the lower end uncrossed. The cylinder is to be implanted with 1.0 mg needles of total length 4.5 cm and active length 3.0 cm, and is to be elliptical with dimensions 3.0 x 4.0 cm. The length of the cylinder will be about 3.5 cm. Use values given in Table 7 below. Determine the treatment time necessary.

VOLUME IMPLANTS			
R_v —mg hr to give 1000 rads to volume implant: Filtration 0.5 mm Pt			
Volume cm ³	R_v mg hr	Distribution Rules	
5	106	Volume should be considered as a surface with 75% radium and core with 25%. Cylinder Belt—30% radium with minimum 8 needles Ends—12.5% radium on each end Core—25% with minimum of 4 needles For each uncrossed end, reduce volume by 7.5% Length = 1.5 2.0 2.5 3.0 Diameter Increase mg hr 3% 6% 10% 15%	
10	168		
15	220		
20	267		
30	350		
40	425		
50	495		
60	556		
80	675		
100	782		
140	979		
180	1156		
220	1322		
260	1479		
300	1627		
340	1768		
380	1892		

The table was prepared from the original by Meredith (41) by multiplying his values by C = 1.066 (Eq. 14-4).

TABLE 7.

1977
PART II
THERAPEUTIC RADIOLOGICAL PHYSICS (PROTECTION)

PT-2. An isocentric 20 MV photon beam and 20 MeV electron beam unit (with beam stopper which protects against scatter from the patient of less than 30 degrees) is to be installed in the space shown. Concrete will be used for shielding in the walls. The workload (W) at 100 cm will be 50,000 rads/weeks, 20% electrons and 80% photons, and the maximum field size is 1200 cm².

- a. Give a brief analysis of the radiation protection problems.
- b. Compute the required thickness of wall B.
- c. Discuss the shielding necessary in the door at P.

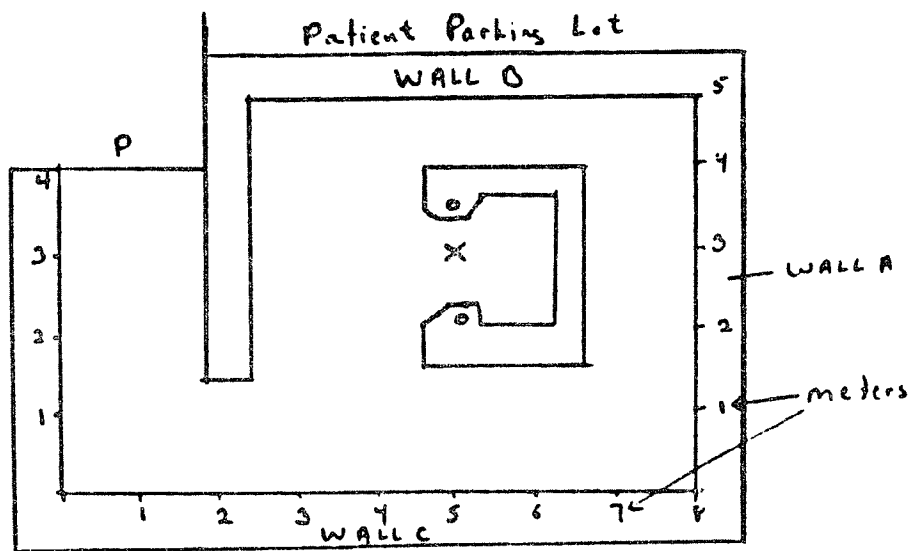

SCATTER FACTOR (400 cm ² FIELD)	(a)	30°	45°	90°	120°
		5.0×10^{-3}	1.4×10^{-3}	0.4×10^{-3}	0.3×10^{-3}
Tenth-Value-Layer (TVL) (cm of concrete)		30	25	20	15
Tenth Value-Layer (HVL) (cm of lead)		3.0	2.2	0.8	0.4

TABLE IV

51
✓

oints

Problem 5

From graphs E.1, E.3, E.6 and E.8 attached, estimate the thickness of concrete required to shield a controlled area from x rays produced by a 1 cm diameter, 3 mA, 6 MeV electron beam incident upon a thick steel target. The x-ray beam is used to treat a maximum expected workload of 40 patients/day, with an average treatment time of 4 minutes/patient.

(5)

Part A:

Assume that the barrier receives forward directed (0°) x rays from the target, with the barrier 4 m from the target and a use factor of 1.

(5)

Part B:

Assume that the barrier receives sideward directed (90°) x rays from the target, with the barrier 4 m from the target and a use factor of 1.

THE AMERICAN BOARD OF RADIOLOGY
1979 RADIOLOGICAL PHYSICS EXAMINATION: PART II

✓

PT - 6

pts.

a) You have just started your first day on the job in the radiotherapy department of a 500 bed community hospital. They have an inventory of "radium" tube sources and Fletcher-Suit type after-loading tandem and ovoid applicators. Their dedicated treatment planning computer is on order. The radiotherapist has a patient scheduled for a GYN tandem and ovoid implant two weeks from today at 7:45 a.m. State your analysis of the situation, and how you would provide good radiological physics services to the radiotherapist and the patient.

pts.

b) 1) List and describe briefly all tests that should be performed following a cobalt teletherapy source replacement. Indicate the acceptable range of measurements for each test listed.

pts.

2) Describe all equipment needed for these tests.

35

PART II MEDICAL NUCLEAR PHYSICS

Part A:

In the operation of a gamma camera, explain and discuss methods for measuring:

1. Spatial Resolution
2. Uniformity
3. Linearity
4. Sensitivity
5. Energy Resolution
6. Resolving time

Part B:

Discuss in detail the effect on the resultant image of photon energy, scatter, pulse height window settings and septal penetration.

MEDICAL NUCLEAR PHYSICS (PROTECTION)

Part A:

A nuclear medicine imaging department plans to use 10 mCi ^{133}Xe per patient and will perform a maximum of 10 studies per week. What ventilation rate is required to maintain air concentration of less than $1 \times 10^{-5} \mu\text{Ci/ml}$ when averaged over a 40 hour week. Assume a leakage rate of 25%.

Part B:

Is this ventilation rate adequate to provide the unrestricted area maximum permissible concentration of $3 \times 10^{-7} \mu\text{Ci/ml}$ at the exhaust vent? (Average over a one year period.)

Part C:

Describe emergency procedures to be used in case of accidental release of ^{133}Xe into an imaging room from storage, traps and/or the administration device.

68
✓

1977
PART II
MEDICAL NUCLEAR PHYSICS

Part A:

A patient is known to have a metastatic lesion somewhere on the anterior surface of his liver. Your Nuclear Medicine Lab is asked to provide information about the lesion using an Anger camera. You are given the following information:

The area of the anterior projection of the liver is 400 cm^2 .

The lesion is 3 cm^2 in projected area.

The lesion is sufficiently deep and nonfunctioning to yield a 6% lower count rate/area than surrounding tissue for the anterior projection.

For N values of x normally distributed about \bar{x} with standard deviation σ , the fraction of values of x greater than x to $k\sigma$ is tabulated:

k	fraction greater than x to $k\sigma$
1	0.16
2	0.023
3	0.0018

CASE 1: Another test has observed the lesion and has established its location. How many counts must be acquired in an anterior liver image to confirm a perfusion defect at this location?

CASE 2: The location has not been clearly established. Using the above table approximate the probability that, for an anterior image of 500,000 counts, a feature having the appropriate size and brightness is not the lesion, but is due to statistical fluctuations.

Part B:

A bolus of activity is injected into the blood, and a certain fraction of the blood concentration is taken up at a rate R_1 by some organ and another fraction of the blood concentration is cleared by the kidneys at a rate R_2 . Assume none is returned to the blood and that you have instantaneous mixing in the blood after injection. Illustrate graphically the activity in the blood, organ and kidneys as a function of time. Explain the various portions of the curve.

N-3. *Part A:*

Part B:

A 10 year old patient is given 2 mCi of macroaggregated albumin (MAA) tagged with ^{99m}Tc for a lung scan. Assume 80 percent of the activity taken up by the lung and the remainder distributed uniformly in whole body. The biological half-life of MAA is assumed to be 2 hours (lung) and 2 days (whole body). Using material supplied in enclosed tables:

- What is the dose to the lung of the patient from activity in the lung?
- What is the dose to whole body of the patient from activity uniformly distributed in the body?
- Consider the possibility of using MAA tagged with 300 μCi of ^{131}I for the lung scan (assume thyroid gland

PART II NUCLEAR MEDICINE

Absorbed Fractions for Uniformly Distributed Sources in Small Unit-Density
Ellipsoids Surrounded by Scattering Medium (Axes 1:2:4)*

Mass (g)	PHOTON ENERGY (McV)									
	0.080	0.040	0.020	0.010	0.100	0.140	0.204	0.303	1.460	2.750
1	0.045	0.021	0.010	0.008	0.008	0.009	0.010	0.010	0.009	0.007
2	0.058	0.027	0.013	0.011	0.011	0.011	0.013	0.013	0.011	0.009
4	0.073	0.035	0.017	0.014	0.014	0.014	0.016	0.016	0.014	0.012
6	0.082	0.040	0.020	0.016	0.016	0.016	0.018	0.018	0.016	0.014
8	0.092	0.045	0.022	0.018	0.018	0.018	0.021	0.020	0.018	0.015
10	0.100	0.049	0.024	0.020	0.019	0.020	0.022	0.022	0.019	0.016
20	0.125	0.063	0.032	0.026	0.025	0.025	0.028	0.028	0.024	0.020
40	0.155	0.081	0.042	0.034	0.032	0.032	0.035	0.035	0.030	0.025
60	0.192	0.101	0.052	0.043	0.040	0.041	0.044	0.044	0.037	0.031
80	0.229	0.121	0.063	0.051	0.049	0.049	0.055	0.052	0.045	0.037
100	0.244	0.131	0.069	0.056	0.053	0.053	0.057	0.056	0.049	0.040

TABLE IV

PART II NUCLEAR MEDICINE

Body Weights and Organ Weights (g) for Various Ages

ORGAN	NEWBORN	1 YR.	5 YR.	10 YR.	15 YR.	STANDARD MAN
Whole body	3,540	12,100	20,300	39,500	55,000	70,000
Brain	350	945	1,241	1,313	1,350	1,400
Heart	20	47	86	140	209	298
Intestines	146	398	550	820	1,350	1,700
Kidneys	23	72	112	187	247	300
Liver	136	333	591	918	1,289	1,700
Lungs	52	172	291	523	701	1,000
Pancreas	2.8	14	23	30	68	80
Spleen	9.4	31	54	101	138	150
Stomach	6.5	27	57	90	120	160
Thyroid	1.9	2.5	6.1	8.7	15.8	20
Testes	0.67	1.5	1.7	2.0	18	28
Ovaries	0.29	1.0	2.0	3.5	6.5	8.5

TABLE II

73

PART II NUCLEAR MEDICINE

Absorbed Fractions for Uniform Distribution of Activity in Small Spheres* and Thick Ellipsoids*

Mass (mg)	0.030 MeV	0.050 MeV	0.040 MeV	0.060 MeV	0.080 MeV	0.100 MeV	0.160 MeV	0.364 MeV	0.662 MeV	1.480 MeV	2.750 MeV
0.3	0.684	0.357	0.191	0.109	0.036	0.085	0.087	0.099	0.096	0.092	0.077
0.4	0.712	0.388	0.212	0.121	0.096	0.093	0.097	0.108	0.108	0.099	0.083
0.5	0.731	0.412	0.229	0.131	0.104	0.099	0.104	0.116	0.117	0.104	0.089
0.6	0.745	0.431	0.244	0.140	0.111	0.105	0.111	0.122	0.124	0.109	0.093
1.0	0.780	0.486	0.289	0.167	0.135	0.125	0.130	0.142	0.144	0.125	0.106
2.0	0.818	0.559	0.360	0.212	0.173	0.160	0.162	0.174	0.173	0.153	0.127
3.0	0.840	0.600	0.405	0.245	0.201	0.188	0.186	0.197	0.195	0.174	0.143
4.0	0.856	0.629	0.438	0.271	0.222	0.209	0.205	0.216	0.213	0.190	0.156
5.0	0.868	0.652	0.464	0.294	0.241	0.227	0.222	0.231	0.228	0.204	0.167
6.0	0.876	0.671	0.485	0.312	0.258	0.241	0.236	0.245	0.240	0.216	0.177

*The principal axes of the small spheres and thick ellipsoids are in the ratios of 1:1:1 and 1:0.667:1.333.

TABLE IV

PART II NUCLEAR MEDICINE

Absorbed Fractions for a Uniform Distribution of Activity in Ellipsoids*

MASS (mg)	0.030 MeV	0.050 MeV	0.040 MeV	0.060 MeV	0.080 MeV	0.100 MeV	0.160 MeV	0.364 MeV	0.662 MeV	1.480 MeV	2.750 MeV
2	0.702	0.407	0.317	0.131	0.072	0.099	0.113	0.112	0.134	0.099	0.096
4	0.762	0.485	0.325	0.176	0.127	0.133	0.144	0.148	0.155	0.133	0.120
6	0.795	0.529	0.345	0.206	0.157	0.155	0.163	0.170	0.173	0.155	0.134
8	0.815	0.560	0.366	0.228	0.179	0.172	0.178	0.187	0.189	0.171	0.147
10	0.830	0.583	0.385	0.247	0.196	0.185	0.190	0.200	0.202	0.183	0.156
20	0.868	0.649	0.460	0.308	0.250	0.233	0.234	0.245	0.250	0.223	0.187
30	0.884	0.685	0.508	0.346	0.284	0.265	0.264	0.273	0.280	0.248	0.207
40	0.893	0.709	0.541	0.374	0.310	0.290	0.287	0.294	0.301	0.267	0.222
50	0.900	0.727	0.567	0.397	0.332	0.312	0.305	0.312	0.317	0.282	0.235
60	0.905	0.741	0.585	0.416	0.351	0.330	0.321	0.327	0.330	0.294	0.247
70	0.909	0.753	0.600	0.432	0.368	0.346	0.335	0.340	0.341	0.306	0.257
80	0.912	0.763	0.613	0.446	0.383	0.361	0.348	0.351	0.351	0.316	0.265
90	0.916	0.772	0.624	0.459	0.397	0.374	0.359	0.362	0.360	0.325	0.274
100	0.918	0.780	0.634	0.471	0.409	0.386	0.369	0.371	0.368	0.334	0.283
120	0.924	0.793	0.652	0.492	0.431	0.407	0.388	0.389	0.384	0.350	0.298
140	0.929	0.804	0.670	0.511	0.450	0.425	0.405	0.405	0.399	0.364	0.310
160	0.933	0.814	0.688	0.528	0.466	0.440	0.421	0.420	0.415	0.378	0.321
180	0.937	0.821	0.708	0.544	0.480	0.454	0.436	0.433	0.432	0.391	0.331
200	0.940	0.828	0.729	0.559	0.491	0.466	0.451	0.446	0.449	0.403	0.340

*The principal axes of the ellipsoids are in the ratio of 1/1.8/8.27.

Points

Problem 1

(4) Part A:

A 0.2 mg point source containing ^{51}Cr is counted at 10 cm from the face of a one inch crystal. The decay scheme for ^{51}Cr is provided. The crystal is known to produce one pulse in the photopeak region for every two incident gamma photons. If the observed counting rate is 4610 cpm and the background rate is 150 cpm, calculate the activity of the source in μCi .

(3) Part B:

If the source is counted for 2 minutes and the background is counted for 5 minutes, what is the standard deviation of the activity in microcuries?

(2) Part C:

What mass in micrograms does this activity represent?

(1) Part D:

What is the specific activity of the source?

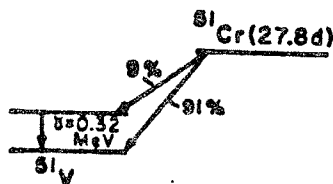

Figure 2-4 Scheme for decay of ^{51}Cr by electron capture.

THE AMERICAN BOARD OF RADIOLOGY
1979 RADIOLOGICAL PHYSICS EXAMINATION: PART II

80

✓

N-2

7 pts Part A

In the evolution of the Anger-type scintillation camera, a number of advances have occurred which have led to improved image quality. Furnish a brief description (not more than 3 sentences each) of each of the advances below, and why each contributes to improved image quality.

1. alkali photomultiplier tubes
2. threshold preamplifiers
3. thin crystals (1/4 or 3/8 in. rather than 1/2 in.)
4. crimped leaf collimators
5. X/Z and Y/Z ratio circuits
6. uniformity correction circuitry
7. time delay buffered storage of count rate data

3 pts Part B

For a scintillation camera, a parallel multihole collimator is replaced by a collimator of similar design, length and septal thickness except that the collimator hole diameter is halved. Assuming that the spatial resolution is determined entirely by the collimator, estimate the improvement in spatial resolution accompanying the exchange of collimators, and the factor by which the photon flux density must be increased to take full advantage of the improved spatial resolution. Briefly describe your reasoning.

In the intravenous administration of $^{99m}\text{TcO}_4^-$, the activity is removed from the blood as it passes through the kidney. In addition, activity is exchanged dynamically between the blood and the extravascular space consisting of a non-specific distribution throughout the interstitial space and a specific accretion of $^{99m}\text{TcO}_4^-$ by the thyroid, stomach, salivary glands and choroid plexus. Shown below is a multicompartamental model of the distribution of $^{99m}\text{TcO}_4^-$ with the extravascular space treated as one compartment and showing rate constants between the compartments.

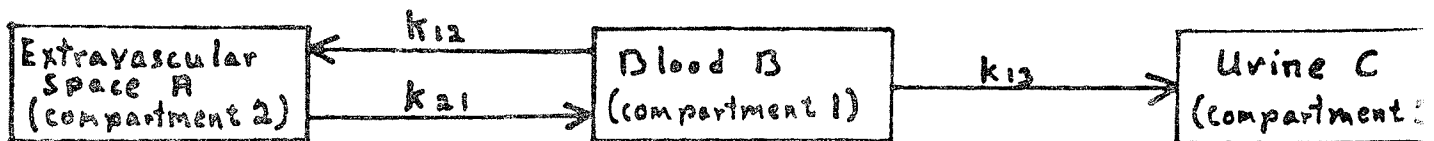

- 2 pts. a) From this model, develop differential equations for the rate of change of activity in each compartment.
- 1 pt. b) With the assumption that the activity in the blood is relatively constant, determine an expression for the activity in the blood as a function of rate constants and the activity in the extravascular space.
- 2 pts. c) From the expression in (b), derive identical expressions for the rate of change of activity in the extravascular space and in the kidneys as a function of the rate constants and the activity in the extravascular space.

To block the uptake of $^{99m}\text{TcO}_4^-$ into the extravascular space, organs in the space often are blocked by pretreatment with perchlorate.

- 1 pt. d) Show how the model in the diagram simplifies if blocking is complete.
- 2 pts. e) With the simplified model, describe an expression for the activity in blood as a function of time, original activity and the rate constant between the blood and urine compartments.
- 1 pt. f) With complete blocking, sketch on a semilogarithmic graph the activity in blood as a function of time.
- 1 pt. g) On the same graph, sketch a second curve representing the activity in blood as a function of time if blocking of the extravascular space is incomplete.

81 ✓

THE AMERICAN BOARD OF RADIOLOGY
1979 RADIOLOGICAL PHYSICS EXAMINATION: PART II

N-3

5 pts.

Part A

The equation for the beta dose inside an infinite medium is given by

$$D_{\beta} = 1.60 \times 10^{-8} \bar{E}_{\beta} \tau \text{ rad}$$

where \bar{E}_{β} is in MeV and τ is in disintegrations/gm. If the volume activity, τ , is given in mCi-week/kilogram, what will the value of the constant be? Calculate the surface dose of an infinite, plane beta-particle source of infinite thickness when $\tau = 50$ mCi-week/kilogram volume activity and $\bar{E}_{\beta} = 0.1$ MeV.

5 pts.

Part B

Consider a radioactive nuclide A decaying into a nuclide B which is also radioactive. Schematically:

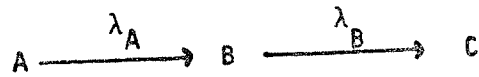

where λ_A and λ_B are the respective decay constants.

- 1) For the initial conditions $A = A_0$ and $B = 0$, derive an expression for $B(t)$ which will contain only the parameters λ_A , λ_B and A_0 .
- 2) Note that at an intermediate time, t_m , the amount B and therefore its activity passes through a maximum value. Derive an expression for t_m .



ints Problem 6

(5) Part A:

A nuclear medicine imaging department plans to use 10 mCi ^{133}Xe per patient and will perform a maximum of 10 studies per week. What ventilation rate is required to maintain air concentration of less than $1 \times 10^{-5} \mu\text{Ci/ml}$ when averaged over a 40 hour week. Assume a leakage rate of 25%.

(3) Part B:

Is this ventilation rate adequate to provide the unrestricted area maximum permissible concentration of $3 \times 10^{-7} \mu\text{Ci/ml}$ at the exhaust vent? (Average over a one year period.)

(2) Part C:

Describe emergency procedures to be used in case of accidental release of ^{133}Xe into an imaging room from storage, traps and/or the administration device.

pts. Part A

Determine the maximum permissible concentration for ^3H as tritiated water from the following information:

Critical organ: whole body (mass = 70,000 g)
Average energy released per decay = 0.0055 MeV

Physical half life: 12.3 years
Biological half life = 22 days

Fraction $^3\text{H}_2\text{O}$ absorbed from GI tract = 0.6
Daily water intake = 2200 ml

pts. Part B

Assuming exponential accumulation of the radionuclide in the critical organ, determine the time in days to reach 99% of the equilibrium concentration of $^3\text{H}_2\text{O}$ in the whole body.

AMERICAN BOARD OF RADIOLOGY

RADIOLOGICAL PHYSICS EXAM

1980

PART 2

Nuclear Medicine

Question 1

(4 pts)

Part A - A pulse height spectrum for ^{113m}In (γ ray of 0.393 MeV) was obtained with a single-channel pulse height analyzer calibrated from 0 to 500 keV. The window width was 2%. Using drawings to illustrate your answer, describe the changes in the spectrum if:

- 1) a 5% window were used.
- 2) the amplifier gain were twice as great.
- 3) the amplifier gain were half as great.
- 4) the upper discriminator of the window were removed.

(10 pts)

Part B - ^{24}Na decays to ^{24}Mg by β^- decay with a $T_{1/2}$ of 15 hr. Isomeric transitions of 4.14 MeV (<1%), 2.76 MeV (100%) and 1.38 MeV (100%) are present during the decay process. A pulse height spectrum for this nuclide exhibits peaks at 2.76 MeV, 2.25 MeV, 1.74 MeV, 1.38 MeV, 0.87 MeV and about 0.20 MeV. Explain the origin of each of the peaks.

Nuclear Medicine

Question 2

(10 pts)

A patient breathes air containing $1 \mu\text{Ci/cc}$ ^{133}Xe for 2 minutes in a lung function test. Calculate the beta doses to the lungs and other tissues in the body resulting from the solubility of Xenon in these tissues.

Mass of lungs	1000 gm
Average beta energy	0.13 MeV
Solubility coefficient (α_v)	
fatty tissue: air	1.7
nonfat tissue: air	0.13

Assume lung and tissue exposure results from equilibration with an air concentration of $1 \mu\text{Ci/cc}$ for 2 minutes.

✓

AMERICAN BOARD OF RADIOLOGY
RADIOLOGICAL PHYSICS EXAM

1980

PART 2

Nuclear Medicine

Question 4

(3 pts) Part A - From the data below, compute the subject and image contrast.

Subject Activity		Image Activity	
Target	Non-target	Target	Non-Target
100 cts/min	20 cts/min	80 cts/min	30 cts/min

For a target periodicity of 1.0 cm, determine the MTF.

(1 pt) Part B - From the data below, estimate the overall FWHM (mm) for the imaging system.

<u>Collimator Resolution FWHM (mm)</u>	<u>Scatter Component FWHM (mm)</u>	<u>Intrinsic Resolution FWHM (mm)</u>
8	10	7

(6 pts) Part C - Sketch pulse height spectra for the following situations:

- 1) ^{99m}Tc spectra at gain settings of 2, 4, and 8.
- 2) ^{99m}Tc spectra at window settings of 2, 5 and 10%
- 3) ^{99m}Tc spectra with a visible iodine x-ray escape peak.
- 4) ^{99m}Tc spectra with a 1 inch and 2 inch thick NaI crystal.
- 5) ^{99m}Tc spectra for a "hot" sample causing considerable pulse summation.
- 6) ^{99m}Tc spectra measured with a NaI and a Ge(Li) detector.

Joe ✓

1980

PART 2

Nuclear Medicine (Protection)

Question 6

(5 pts)

Part A - A patient has received 100 mCi of ^{131}I for treatment of thyroid cancer. Assume patient's 24 hour uptake is 25 percent and that the effective half-life of the iodine is 6 days. Should the patient be hospitalized, what should be done about the radioactive urine, and what other precautions should be taken with respect to this procedure?

(5 pts)

Part B - A department of nuclear medicine in a metropolitan hospital is conducting studies with Xenon-133 and releasing the recovered Xenon through a hood to a discharge point on the roof of the building. The velocity of flow of gas through the hood, when the area of the opening is 3.0 ft^2 , is 250 linear ft/min, as measured with a velometer. What is the maximum permissible weekly discharge rate? What are the restrictions when Iodine-131 is also discharged through the hood?

Maximum Permissible Concentrations of Radionuclides in Air

RADIONUCLIDES	UNRESTRICTED AREAS	RESTRICTED AREAS (40 HR WEEK)
	AIR (pCi/cc)	AIR (pCi/cc)
^{14}C	0.1	4
^3H	.2	5
^{35}S	.009	0.3
^{131}I	.0001	.009
^{125}I	.00008	.005
^{32}P	.002	.07
^{45}Ca	.001	.05
^{24}Na	.005	.1
^{42}K	.004	.1
^{51}Cr	.08	2
^{85}Kr	.3	10.
^{133}Xe	.3	10
^{82}Br	.006	0.2
^{36}Cl	.0008	.02

SOURCE: U.S. Code of Federal Regulations, Title 10, Part 20, as of December 10, 1969.

NOTE: The maximum permissible concentration depends on several factors, including the degree of solubility of the contaminant. The lowest concentrations specified in the regulations have been listed.

1. A film compressed between solid water and with its edge flush is exposed to an electron beam. The film is developed and scanned, thus producing a plot of optical density versus depth, \bar{x} .

A characteristic curve of optical density vs. absorbed dose is supplied.

Using the graph paper and the relation

$$R_p = .521 E_0 - .376, \text{ find the Energy } E_0$$

of the electron beam.

2. Define the following in terms of 6 given diagrams:

- a) BSF (A)
- b) PDD (A, S, d)
- c) TAR (A, d)
- d) TAR (A, d) in terms of PDD
- e) TMR (A, d)
- f) PDD at S versus PDD at S + K

where A = area

S = source to skin distance or isocentric distance

d = depth in tissue

3. A small volume (0.2 cm^3) shielded ionization chamber consisting of carbon, aluminum, and air is drawn. Its exact dimensions are given.

- a) Define \bar{x} or effective \bar{x} .
- b) Determine \bar{x} for the chamber, neglecting air.
- c) How does your result differ from that of water and what is the significance of this?

4. A 6 MeV accelerator is calibrated at 100 cm SSD at 5 cm. deep in water. The field size at d_{max} is $10 \times 10 \text{ cm}$. The electrometer reads 82.3 for a 20 sec. exposure. The Cobalt-60 calibration factor is 1.07 and the timer correction error is -0.04. C_A and %DD values are given.

- a) What is the dose rate at d_{max} ?
- b) What is the scattered radiation at 10 cm. deep in 2 minutes?
- c) How would you measure the timer error?

Protection Problem #1:

Apparent discrepancy between teletherapy licensing guide and CFR 20.105 (a) and (b).

- a) How might the NRC explain this apparent contradiction?
- b) What would be the difference in barrier thickness between $\bar{u}=1$ and $\bar{u}=1/4$?
- c) Why should we not use an occupancy factor of less than 1/8 for unrestricted areas?

Protection Problem #2:

- a) Explain the mechanism of neutron production in an 18 MeV accelerator.
- b) How would you measure the dose rate from neutrons?
- c) How would you plan protection from the neutrons produced?

December 1983

In the following pages are our recollections of the ABR written examination of 1983. We tried to recall question categories, subjects, and in some cases, exact questions, that we 1) couldn't answer and 2) will never forget as long as we live. The Part I was a jumble of basic physics to the point of ad nauseum. There are a lot of questions on such a diverse spectrum of subjects. Between the multiple choice, the multiple-multiple choice, and the true-false or matching questions, there are easily 1000 questions. We only took Part II in therapy and that part was seemingly more reasonable (reasonable being that they asked us recognizable things), but one must still work very fast in order to organize and write out the essay answers within the time period allowed.

We can't really give good advice on how or what to study--we passed, but we're not quite sure how.

Good Luck

WRITTEN BOARD EXAMINATIONS 6-7 October 1983

Part I PHYSICS

1. Many detailed question on ultrasound--about the speed of sound in various tissues, what changing transducer sizes would affect, what changing the MHz would do, freznel zone, Franhoffer zones, etc, ad nauseum
2. Many detailed question about NMR, about T1, T2, Larmor frequencies, reconstruction, magnest, the effect of changing magnet size, tissue characterization, the elements looked at, significant parameters of isotopes giving off resonance, etc, etc
3. Given a volume of mercury and it's linear expansion coefficient, what cross sectional area should the thermometer be in order that the centigrade degree marks are 2 mm apart?
4. Given the barometric readings at the top and bottom of a tall building, what is the height of the building?
5. Expected to know about linear stree on bones (biomechanics), shear forces, stress forces
6. Basic physics question on throwing projectiles in the air
7. Basic questions on electricity and batteries, EMF flow, circuit diagrams
8. Expected to know about fluid dynamics
9. Only one question on CT--what does a CT number represent? (Choice of density, linear attentuation coefficient, electron density?)
10. Statistics--define mean
11. The line source in measuring MTF question in the set of available ABR sample questions
12. Cell kinetics--most sensitive part of cell cycle
13. MIRD doses to empty gall bladder
14. Identifying the products of differnet types of radioactive decay
15. Units of dose equivalentents
16. Ionization chambers containing one gram of air
17. OER, RBE, LET
18. Hit theory, single hit, multiple hit, etc
19. Tissue radiosensitivity
20. Binary and octal

WRITTEN BOARD EXAMINATIONS 6-7 October 1983

Part I PHYSICS--continued.....

21. Computer bytes
22. Analog to digital conversion
23. Computer interfacing
24. Limiting rates and acceptance of digital impulses/flow
25. Compton electron recoil energies
26. Beta decay--conservation of mass and energy
27. Approximation of E_{av} in $1/3 E_{max}$

WRITTEN BOARD EXAMINATIONS 6-7 October 1983

Part I CLINICAL QUESTIONS

1. Given a CAT scan of pelvis--identify the prostate, bladder, rectum, head of femur
2. Given a CAT scan of abdomen--identify the kidney, aorta, pancreas, splinal column
3. Given a drawn diagram of the heart, identify the various chambers of the heart, major veins and vessels, heart valves
4. Given a set of six ultrasound scans--identify which represents a fetus, gall bladder with stones, aorta, and various other structures or conditions.
5. Trace the flow of blood through the heart and lungs
6. Match which diagnostic test are used to diagnose various conditions such as gall stones
7. What is a VAGUS?
8. What is an oligodendroma?
9. Match various cancers with their disease sites
10. CT of head and neck region--identify the optic nerve, eyeballs, brain hemispheres, bones in the region.
11. GI system--put in correct order the duodenum, ileum, jejunum, stomach, etc
12. Difference between sarcomas and carcinomas
13. Questions about buffers in the body--chemical composition, concentration, results of changing concentrations
14. Blood cell catagories--RBC, lymphocytes, erythrocytes, etc

Part II THERAPY PHYSICS

Therapy: Choose three out of four questions

CHOICE 1: Describe the dimensions, material, construction, density, placement, and purpose of linear accelerator beam flattening filters and scattering foils.

CHOICE 2: Describe the advantages of treating breasts by tangential opposed beams.

Draw the isodose curves in the breast with and without wedges in the beam.

How would you treat a patient if you needed to use a 15 degree wedge, but all you have available was a 30 degree wedge?

CHOICE 3: Told that you are to treat a hemibody at an extended SSD. Given various distances, field sizes, depth doses, etc. Calculate the μ needed to deliver a certain dose. (Took a long time to correct and justify each factor-- such as inverse square, equivalent squares of fields, Mayneord's F-factor, approximations).

What are the potential complications of these treatments?

CHOICE 4: Given a geometric picture of a simulation film. A surgical clip is off the central axis of the simulation film, you are to determine the actual distance that the clip is from the actual field border.

Derive the equation from basic geometry for a gap, or field matching at depth.

WRITTEN BOARD EXAMINATIONS 6-7 October 1983

Part II THERAPY PHYSICS

Radiation Safety: Choose one question.

CHOICE 1: Given a treatment room with a cobalt machine and given shielding, how much shielding should be added to present shielding when the machine is changed to a 6MV linear accelerator? You are given only information on present shielding and HVL's and TVL's of certain materials.

CHOICE 2: Given a diagram of a hospital floor--a set of rooms and nurses station. Told that patient in certain room has a Cs implant. You are given the dose rates at various points on the hospital floor and information (sex and ages) of the occupants of the adjoining rooms.

You are asked:

1. Whether the dose rates at each point are acceptable.
2. Whether the nurses at the nursing station need to be monitored with film badges.
3. If you could rearrange the patients in their rooms, which patients would you move and where.

Under all of the three questions, you were supposed to elaborate on permissible dose rates, and philosophy of radiation protection.

PART ONE - MULTIPLE CHOICE QUESTIONS
SECTION A

1. The potential energy of a proton in a 1 T magnetic field is given by:-

2. The field strength of a 0.5 T magnet was measured at a distance d meters as 15 gauss. If the distance was doubled, the field strength would be:-

3. The resistance of a 15 gage wire of 100 m length is 8Ω . 100 meters of a 10 gage wire made of the same material is connected to a 230 Volt circuit breaker. The current flowing was measured at 0.5 amps. The voltage in the circuit is:-

- A. 222.7 V B. 228.8 V C. 230 V D. 233.2 V E. 237.4 V

4. The mechanical advantage of a pulley system such as shown alongside are:-

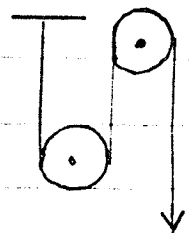

- A. 1 B. 2 C. 3 D. 4 E. 6

5. Consider a freshly prepared sample of Sr^{90} . Time taken (in hours) in total for γ^{90} to reach 90% of its peak activity will be:-

- A. 100 B. 150 C. 200 D. 215 E. 250

6. A daughter isotope with b hours half life is in equilibrium with a parent isotope with half life a hours. The activity of the daughter isotope is:-

64 mCi of the parent alone, the activity of the daughter 104 hours later will be:

- A. Zero B. 16 mCi C. 64 mCi D. 256 mCi E. 1 Ci

7. If the radius of the first orbit of an atom is a , the radius of the second orbit will be:

- A. $a\sqrt{2}$ B. $2a$ C. $3a$ D. a^2 E. $a^{3/2}$

8. A 10 kg mass travelling with a velocity of 1 m/sec collides with a 1 kg mass at rest. After the collision, both of the bodies travel together. Their combined velocity is:

- A. 1 m/sec B. 1.1 m/sec C. 0.9 m/sec D. 0.5 m/sec

9. Which of the following circuits represents a voltage follower?

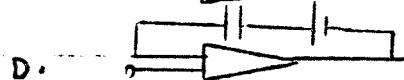
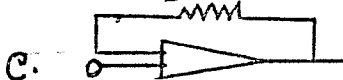

10. The absorbed dose at the center of a 1 gram mass was estimated as 1 rad. Assuming little absorption in tissue, dose to the same point surrounded by 2 grams of tissue is:

- A. 0.5 rad B. 1 rad C. 2 rads D. 4 rads

11. A 6 MV linear accelerator is used to treat a tumor at 10 cm depth. The treatment was done with a 110 cm SSD. However, the depth dose tables are available only for 100 cm SSD. Assuming $d_{max} = 2$ cm,

correction factor that must be used to multiply the percentage depth dose obtained from the table is:

A. $\left(\frac{112}{110}\right)^2 \cdot \left(\frac{102}{120}\right)^2$

B. $\left(\frac{112}{120}\right)^2 \cdot \left(\frac{110}{102}\right)^2$

C. $\left(\frac{110}{112}\right)^2 \cdot \left(\frac{120}{102}\right)^2$

D. $\left(\frac{110}{112}\right)^2 \cdot \left(\frac{102}{120}\right)^2$

E. $\left(\frac{112}{102}\right)^2 \cdot \left(\frac{110}{120}\right)^2$

12. In survival studies with human cells, the extrapolation no has been found to be in the range of:

A. 0 to 1 B. 1 to 2 C. 2 to 5 D. 5 to 10 E. 10-20

13. In normal human beings, no of platelets per cubic mm of blood is in the range of:

A. 2000 B. 20000 C. 200000 D. 2 million E. 6 million

14. A source yields an average count rate of 5 cpm. Assuming that counting follows Poisson statistics, probability of obtaining exactly 4 counts in a minute is:

A. 0.01 B. 0.18 C. 0.8 D. 0.95 E. 0.25

15. If the gross count rate from a sample is 10000 cpm and the background count rate is 100 cpm, the most efficient distribution of counting time will be in the ratio:

A. 9:1 B. 1:9 C. 10:1 D. 1:10 E. 100:1

16. The statistical parameter used to test for the significance of the difference between two measurements is called:

A. Mean B. Standard deviation C. χ^2 D. t value

17. The number of bits in the memory needed to represent a 256 x 256 matrix, with each pixel representing seven shades

of Gray is:-

- A. 46000 B. 8.4×10^6 C. 66000 D. 10^6 E. 10^9

18. In principle, FeSO₄ dosimeter measures a change in — of a solution:-

- A. Temperature B. Optical density
C. pH D. Solubility E. Concentration

19. Movement of ions across a cell membrane is accomplished by a mechanism known as:-

- A. Osmosis B. Diffusion C. Active transport
D. Capillary action E. Pinocytosis

20. Best definition of a transducer is that it is a device that:-

- A. Converts one form of energy into another
B. Transmits ultrasound
C. Receives ultrasound
D. Generates pressure waves from electricity

21. Which of the following cells is not a white blood cell?

- A. Lymphocyte B. Monocyte C. Neutrophil
D. Thrombocyte E. Granulocyte

22. Cells arranged in decreasing order of sensitivity are:

- A. Fibrocytes, Sperm, Endothelium, Lymphocyte
B. Lymphocyte, Sperm, Endothelium, fibrocyte
C. Sperm, Endothelium, Fibrocyte, Lymphocyte
D. Endothelium, Fibrocyte, Sperm, Lymphocyte
E. Lymphocyte, Endothelium, Sperm, Fibrocyte

23. In Computed Tomography, the Hounsfield number assigned to water is:-

- A. -1000 B. -100 C. 0 D. 100 E. 1000

24. Correction must be applied to the measurements taken with a Free air chamber for all of the following except:-

- A. Photon attenuation between diaphragm and collecting volume
B. Recombination of ions produced
C. Ionization produced by photons scattered from beam
D. Ionization produced by electrons originating outside the collecting volume
E. Loss of ionization due to inadequate separation of electrodes

25. The "master gland" of the human body whose secretions control the actions of other endocrine glands is:-

- A. Pineal gland B. Thyroid gland C. Pituitary gland
D. Suprarenal gland E. Parathyroid gland

26. In imaging with a gamma camera, an acceptable value for information density in counts/cm² is:

- A. 20 B. 200 C. 2000 D. 20000 E. 200000

27. Concrete used as a shield for high ~~density~~ energy gamma radiation should have a minimum density of:

- A. 2.2 g/cm³ B. 137 lb/ft³ C. 235 lb/ft³
D. 1.47 g/cm³ E. 2.35 g/cm³

28. The best possible configuration for a beta shield is:-

- A. Low Z plastic B. High Z lead C. Medium Z

29. If a GM counter with a resolving time of $150 \mu\text{s}$ yields a count rate of 10000 cpm , the true count rate would be:-

- A. 10200 B. 10256 C. 10375 D. 10762
E. 11024

30. You are interested in finding the TMR value for a rectangular field of size $12 \times 6 \text{ cm}^2$. However the TMR tables list only values for square fields. The needed TMR would be listed under a field size of:

- A. 6×6 B. 8×8 C. 10×10 D. 12×12 E. 7×7

31. A lateral film of the lumbar spine was taken for a patient whose thickness was 40 cm . If the target to skin distance was 60 cm and if the skin to film distance is 5 cm , magnification factor will be:

- A. 1.1 B. 1.2 C. 1.3 D. 1.4 E. 1.5

32. An ionization chamber has been calibrated at 22°C and 760 mm Hg . If measurements are made at 21.5°C and 754 mm Hg , the reading of the instrument should be multiplied by:-

- A. 0.9904 B. 0.9938 C. 1.006
D. 1.010 E. 1.015

33. What is the minimum detectable activity (at 95% confidence level) for a well type scintillation counter whose background is 16 cpm and whose sensitivity is 50%?

- A. 4 RA B. 2 RA C. 16 RA D. 32 RA E. 64 RA

34. Hematocrit is the term used to describe the % of _____
in the plasma:-

- A. White Blood cells B. Red blood cells C. Platelets
D. Formed elements E. Protein

35. The sudden blocking of an artery by some foreign material is termed:

- A. Blood clot B. Stenosis C. Embolism
D. Fibrosis E. Sclerosis

36. The most significant contribution to genetically significant dose arises from:-

- A. Natural Background B. Medical exposure
C. Nuclear Power D. Nuclear explosions E. Internal activity

37. In the region of medical interest, the range of electrons may be denoted approximately by:

- A. 1 MeV/cm B. 1 MeV/cm C. 1 MeV.cm²/gm
D. 2 MeV/cm E. 2 MeV/(gm/cm²)

38. The signal to noise ratio of the conventional well counting system can be improved considerably by using:

- A. Shielded sources B. Higher gain C. Lower voltage
D. Discriminators E. Count rate meters

39. The major part of the radiation damage produced in mammals arises from:

- A. Direct effects B. Ionization of nucleoproteins
C. Inactivation of enzymes D. Hemorrhage
E. Production of free radicals

40. The organ which serves as the reservoir of erythrocytes is:

- A. Bone Marrow B. Spleen C. Liver
D. Pancreas E. Heart

41. In any counting experiment, an acceptable loss of count rate would be:

- A. 1% B. 2% C. 3% D. 5%
E. 10%

42. Temporary sterility can be induced in the human male after a radiation dose of:

- A. 50 rads B. 100 rads C. 150 rads
D. 200 rads E. 250 rads

43. Treatment planning should aim at an accuracy of:

- A. 0.1% B. 0.5% C. 1%
D. 2% E. 5%

44. In a Technetium - Molybdenum generator, an acceptable level of Molybdenum contamination in the Technetium extracted is:-

- A. 0.1% B. 0.5% C. 1%
D. 2% E. 5%

SECTION B

In this section, each question is followed by four or five statements. Mark each statement as True or False.

71. According to NCRP Report 39, 0.5 rem/year is the maximum permissible dose equivalent for :-

- A. Individual member of the public
- B. Member of the public, occasionally exposed
- C. Fetus, during the gestation period
- D. Family of patients administered with radioisotopes
- E. Occupational workers under 18 years.

72. The isotopes of Iodine that have been used for 24 hour thyroid uptake studies are :-

- A. Iodine 123
- B. Iodine 125
- C. Iodine 128
- D. Iodine 129
- E. Iodine 131

73. The isotopes whose internal structure confirms the validity of shell structure are :-

- A. ${}^2_1\text{H}$
- B. ${}^3_2\text{He}$
- C. ${}^4_2\text{He}$
- D. ${}^2_2\text{He}$
- E. ${}^6_2\text{He}$

74. The capacitance of a parallel plate capacitor depends upon :-

- A. Area of the parallel plates

- B. Distance between the plates
- C. Voltage applied between the plates
- D. Nature of the dielectric material
- E. The material of the plates

75. Photoelectric effect :-

- A. Cannot occur with a loose electron.
- B. Coefficient increases as Z increases
- C. Coefficient decreases as energy decreases
- D. Most probably occurs with electron closest to nucleus
- E. Is almost always followed by a fluorescent xray.

76. In calorimetric measurements, the heat produced can be measured with:

- A. Thermocouples
- B. Thermopiles
- C. Thermistors
- D. Resistance bridges
- E. Pyrometers

77. Oxygenated blood is found in :-

- A. Right Atrium
- B. Left Atrium
- C. Right Ventricle
- D. Left Ventricle
- E. Pulmonary artery

78. Among victims of an Atom Bomb explosion, there has been noted an increase in :-

- A. Leukemia
- B. ...

- C. Still births
- D. Mental retardation
- E. Genetic disorders

79. Hall effect is:

- A. An example of force on a charged particle
- B. Dependent on the intensity of electromagnetic field
- C. Dependent on the nature of charge carriers
- D. Dependent on the speed of charge carriers
- E. Measured by determining the voltage induced.

80. The gravity on the moon is one-sixth the gravity on the earth; this means:-

- A. A person will weigh $\frac{1}{6}$ his earth weight.
- B. He can lift weights six times greater.
- C. He can run six times faster.
- D. His metabolic rate will be one sixth
- E. He can jump six times higher.

81. Which organ is not part of the nervous system?

- A. Diencephalon
- B. Pia Mater
- C. Foramen Magnum
- D. Epidural space
- E. Semilunar folds

82. The width of the penumbra depends upon:

- A. Focal spot size
- B. Source to image receptor ~~size~~ distance
- C. Source to object distance

D. Object to image receptor distance

E. Field size

83. Study the radioactive decay scheme given alongside and then answer the following questions:

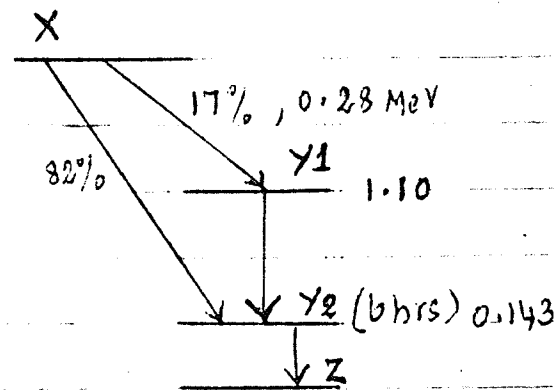

A. Beta particles are emitted in 17% of disintegrations.

B. Highest energy of beta particle emitted is 0.68 MeV.

C. Y2 is a metastable isotope.

D. The atomic number of Y2 is one greater than X.

E. Two gamma photons are emitted for each disintegration of X.

84. In a radioisotope that decays exclusively by isomeric transition, the following radiations are possible:-

A. Gamma Radiation

B. Conversion Electrons

C. X radiation

D. Auger electrons

E. Antineutrinos

85. For Aluminium, the electron energies are: K shell

1.559 KeV, LI shell 0.087 KeV, LII shell 0.072

KeV, M shell 0.005 KeV. Which of the following

characteristic X-rays are theoretically possible:-

A. 1554 eV

B. 1472 eV

C. 1487 eV

D. 15 eV

E. 5 eV

86. A Tc^{99m} generator :-

A. Can be milked daily

B. Radioassays must be carried out separately for each eluate.

C. Cannot be used for more than a week.

D. Will always yield Tc^{99m} contaminated with Mb^{99} .

E. Yield a constant amount of Tc^{99m} per constant volume of the eluate.

87. Given P_{15}^{31} is a stable isotope :-

A. P_{15}^{30} would be a positron emitter

B. Electron capture is possible with P_{15}^{28}

C. The half life of P_{15}^{33} would be of the order of days.

D. P_{15}^{33} would be a pure beta emitter.

E. P_{15}^{29} would emit neutrons.

SECTION C

In this section, four or five items are given followed by an equal number of questions. Match the question with the item which forms the most appropriate answer.

Match the hormones with the organs secreting them:-

- A. Norepinephrine
- B. Glucagon
- C. Progesterone
- D. Thyroid Stimulating Hormone
- E. Thyroxine

137. Thyroid gland

138. Pituitary gland

139. Pancreas

140. Ovary

141. Adrenal medulla

Consider the case of an atom with three principal quantum numbers:- (The same answer may apply to more than one question)

1. 2

2. 7

3. 3

4. 0

142. Number of different values of spins

143. Total number of different magnetic orbital quantum numbers.

144. Total number of orbital quantum numbers

145. No. of electrons with 1 as principal quantum numbers

146. The orbital quantum numbers corresponding to $n = 1$

Match up the types of cancer with the type of cell or organ.

Where it originates

- A. Adenoma
- B. Lymphoma
- C. Osteoma
- D. Chondroma
- E. Melanoma

- 147. Cartilages
- 148. Pigmented cells
- 149. Glandular epithelium
- 150. Lymphoid tissue
- 151. Bone

Match up the clinical test with the purpose for which it is done.

- A. Serum bilirubin test
- B. Schilling's test
- C. T3 test
- D. Glucose test
- E. BUN test

- 152. Thyroid function
- 153. Diabetes
- 154. Vitamin B-12 absorption
- 155. Liver function
- 156. Kidney function

Match the parts of the Semihilation Spectrum, with their appropriate names.

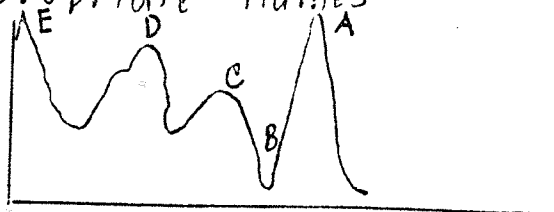

- 157 Compton Edge
- 158 Compton Plateau
- 159 X ray peak
- 160 Photopeak
- 161 Backscatter peak

Match the following electronic circuits with their appropriate function.

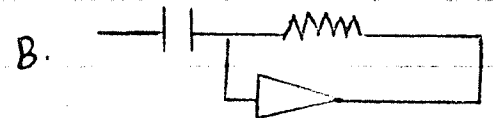
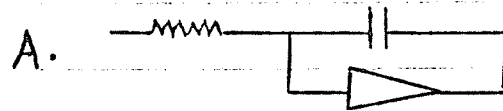

- 162 Adder
- 163 Current Source
- 164 Current Voltage converter
- 165 Integrator
- 166 Differentiator

A CT view of the portion of digestive tract was given and five organs identified with letters A to E. Identify these organs.

- 167 Jejunum
- 168 Cecum
- 169 Greater Omentum
- 170 Gall Bladder
- 171 Duodenum

Another CT view of the heart and the great vessels were

With areas marked A - E. Identify these regions.

- 172. Aortic arch
- 173. Left Ventricle
- 174. Right Atrium
- 175. Superior Vena Cava
- 176. Pulmonary artery

From long experience, it is known that the count rate from a scintillation counter for some setting. Given the following sets of background count rates (cpm), match them with their appropriate characterizations.

- A. 100, 100, 100
- B. 99, 100, 101
- C. 85, 97, 108
- D. 70, 70, 70
- E. 95, 95, 95

- 177. Inaccurate
- 178. Accurate
- 179. Imprecise
- 180. Precise
- 181. Biased

Match the dimensions given with the quantities for which they are appropriate.

- A. T^{-1}
- B. MLT^{-1}
- C. MLT^{-2}
- D. ML^2T^{-3}
- E. L^2T^{-2}

- 182. Absorbed dose
- 183. Activity

184 Power

185 Momentum

186. Force

Match the type of cells with the system in which they commonly occur.

A. Basal cell

B. Ganglion

C. Phagocytes

D. Glomerulus cell

E. Leydig cell

187. Reticuloendothelial system

188. Nervous system

189. Urogenital system

190. Reproductive system

191. Skin

Match the accelerator with its principle of operation.

A. Van de Graaf generator

B. Linear Accelerator

C. Betatron

D. Cyclotron

E. Microtron

192. Accelerates charged particles across Dees placed in a magnetic field

193. Electrons accelerated by oscillating electric field of a microwave cavity.

194. Electrons are transported by belt to higher voltage

195. High frequency electromagnetic waves accelerate electrons.

196. Electrons are accelerated by changing magnetic fields.

I. THERAPEUTIC RADIOLOGICAL PHYSICS

I A 6 MV photon beam from a linear accelerator is used to treat a patient with AP thickness of 20 cm. The field configuration at 100 cm SAD is shown alongside, with the shaded area under a block. The machine has an output of 220 rads/min at 100 cm and d_{max} depth. Given the following information:-

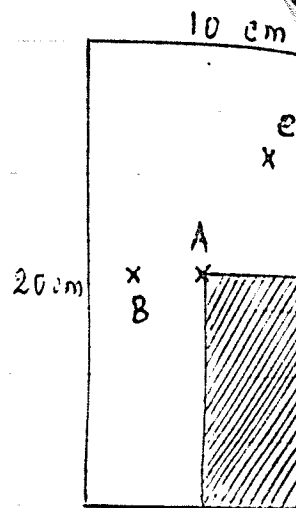

- 1) Off axis ratio table at d_{max}
- 2) TMR table listing values of TMR at various depths for field sizes of 5×5 , 10×10 and 15×15

Calculate the dose rate at the following points:

- a) Point A at a depth of 10 cm for unblocked field
- b) Point B at a depth of 5 cm for the blocked field
- c) Point C at a depth of 10 cm for the blocked field

It may be assumed that off axis ratios do not change with a change in depth.

II. Given a figure similar to that drawn alongside, with the inner contour representing the inhomogeneity and the slanted line representing a photon beam:

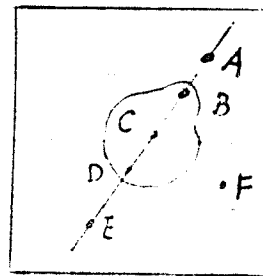

(a) Discuss the change in dose at the points A through F.

(b) Discuss how you would correct for the inhomogeneity using the following methods:

- (i) TAR
- (ii) Bath's power law method
- (iii) GSDose Shift method

Use any one method to illustrate the example.

(c) What is a CT number? How do you use this number in radiation therapy when it is obtained from a diagnostic CT image?

III Discuss total body irradiation as a technique to treat myeloid leukaemia, with reference to the following points.

(a) What kinds of beams and energies would you use (e.g. electron, photon, neutron etc)?

(b) Describe the characteristics of the beam and actual technique of irradiation.

(c) How would you calibrate such a beam and how would you obtain the percent depth doses?

(d) How would you treat normally inaccessible areas such as inter-finger space and axilla?

IV Given two figures similar

to those given alongside.

Using the notation that

d_1, d_2 etc are depths

of points P_1, P_2 etc,

D_1, D_2 are doses in air

at these points and D_1', D_2'

are doses in water at these

points, d_{max} being the maximum depth, give the

mathematical definition of the following quantities

used in therapeutic radiological physics, taking care

to include the parameters that are normally associated

with them:

(a) Inverse Square Law

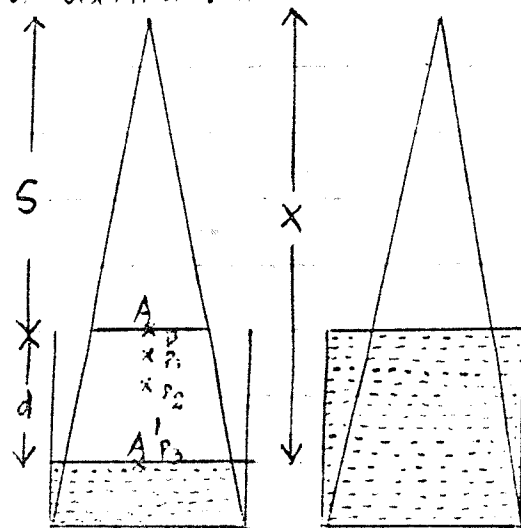

- (b) Peak Scatter factor
- (c) Percent depth dose (must be defined using two entirely different sets of points)
- (d) Tissue Air Ratio
- (e) Tissue Maximum Ratio
- (f) Scatter factor
- (g) Tissue Phantom Ratio (can it be defined using the quantities given in the illustration, or are additional assumptions necessary?)

V Given alongside is a layout of a 6 MV linear accelerator facility. The machine is located at point P, at 10' from the

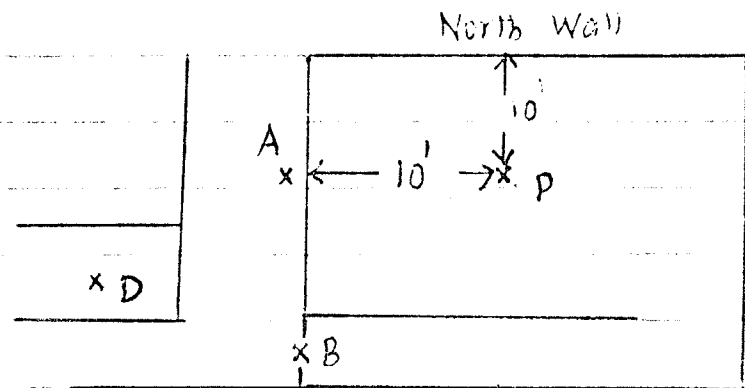

North and West walls. (No other distances were given, but presumably the layout was to scale). Approximately 10% of the beam is pointed towards the East wall for total body irradiations. Making whatever assumptions necessary, calculate the shielding necessary at the points given below:

- A) Control Room
- B) Lead lining for the door
- C) Outside the East wall
- D) Janitor's closet
- E) Ceiling, which is never occupied

VI Briefly discuss the radiation protection aspects of using brachytherapy sources. Consider aspects of storage, preparation, transportation, personnel monitoring etc. How would you calculate shielding necessary after the sources are inserted into the patient?

II. DIAGNOSTIC RADIOLOGICAL PHYSICS

I. (a) List and discuss the different parameters that influence image resolution in Computed Tomography.

What factors must be taken into account in comparing the performance of several different CT scanners?

(b) What is the maximum resolution that can be obtained with a pulsed Ultrasound system with a pulse duration of 2 μ s? Is this resolution considered acceptable?

II. Discuss magnetic resonance imaging in comparison with conventional imaging techniques. What are its principal advantages? How does it differ from computed tomography in scans of white and gray matter of the brain? How can pulse sequencing be used to enhance the relative contrast between tissues?

III Discuss mammography from the point of view of equipment and techniques used today.

Discuss changes in image quality and patient dose with operating parameters.

How does the resolution in mammography change with the imaging method used?

What are the different methods of designating the dose to the breast in mammography? In your opinion, which method is superior? Why?

IV What are the components of a digital subtraction angiography system? How does the resolution obtained in this procedure compare with the resolution obtained in conventional radiography?

and fluoroscopy?

V What are the special considerations in pediatric radiology? What additional precautions must be taken to ensure minimal exposure to the pediatric patient?

Enclosed are:

(1) Graph relating R/min^{ma} at 1m for different combinations of Filtration and KVp.

(2) Table relating skin exposure to dose to thyroid, red marrow and gonads for different types of examinations and different depths of organs (values listed are in units of rads/R)

Calculate the dose to the thyroid, red marrow and gonads of a male child who undergoes an abdominal examination of 60 KVp, 5 mas.

VI You have been chosen to supervise and evaluate the ^{radiation protection} ~~the~~ ⁱⁿ the setup of a laboratory that will use labeled monoclonal antibodies in tumor ~~for~~ detection. Discuss the various factors that you must consider during the course of this project.

III MEDICAL NUCLEAR PHYSICS

I. Describe the principle underlying Single photon emission computed tomography (SPECT).

Describe the characteristics of the essential auxiliary instrumentation needed.

What is the order of resolution obtainable with the procedure?

II. What tests would you do for performance evaluation of a gamma camera? What are the parameters that are measured by these tests?

What is meant by peaking a gamma camera? How is it done?

What are the effects of a pulse pile up?

III. Your department head, who is a physician, has made you responsible for setting up a system for cardiac imaging. He has very little knowledge of physics, so you have to evaluate the systems commercially available and choose one. Describe the various characteristics that you would consider in comparing systems.

IV. Commercially produced I^{123} (Half life 13.3 hours) is often contaminated with I^{124} (Half life 4.2 days) and the extent of contamination is often difficult to determine using an isotope calibrator. An article on this subject appeared in the Journal of Nuclear Medicine. It detailed a method by which the I^{124} contamination was determined. The I^{123} sample was placed in the isotope calibrator and

another with the sample surrounded by a $\frac{1}{4}$ " thick lead shield. From these two measurements, the activity of the contaminant was calculated using a mathematical expression. The problem involves the derivation of that expression. You are given a graph which shows:

- 1) Decay of the mixture over several days
- 2) Decay of the mixture, inside the $\frac{1}{4}$ " lead shield over several days
- 3) Decay of pure I^{123} over several days
- 4) Decay of pure I^{124} over several days

V. In a radiation accident, a worker was exposed to Tc^{99m} and I^{131} , with a resulting intake of 80 hours at their respective maximum permissible concentrations. During the year, he has accumulated an external exposure of 1 rem. Does the accidental exposure exceed the applicable guidelines? Given:

$$\text{MPC of } Tc^{99m} = 4 \times 10^{-5} \text{ } \mu\text{Ci/ml}$$

$$\text{MPC of } I^{131} = 9 \times 10^{-9} \text{ } \mu\text{Ci/ml}$$

$$\text{ALI of } I^{131} =$$

$$\text{ALI of } Tc^{99m} =$$

VI. What precautions would you use in case of patients who have been treated with I^{131} for thyroid cancer and hospitalized?



Wayne State University
School of Medicine

C.7 PHYSICS OF NUCLEAR MEDICINE

- (I) You have been asked to review proposals for human research that will include the administration of diagnostic doses of radiotracers in clinical use to normal subjects. List and, from the perspectives afforded by the ALARA principle, comment on the principles by which a Radiation Safety Committee could, in general, evaluate such proposals.
- (II) Briefly discuss the principles of radioprotection as they apply to clinical practice of nuclear medicine. Provide specific examples of the applications of each of these principles.
- (III) Outline a bioassay program suitable for research workers involved in labelling compounds with I-125 and/or I-131.
- (IV) Briefly describe the methods used to monitor for stray radioactivity following a spill involving 37 MBq of I-131. Provide an outline of decontamination procedures in such a situation and describe what future actions, if any, may be necessary.



Wayne State University
School of Medicine

C.8 PHYSICS OF NUCLEAR MEDICINE

- (i) Using diagrams to aid you, describe the principle components of a scintillation camera (single crystal, Anger design) and define the function of each component.
- (ii) By considering each component of the detector head in turn, starting with the collimator, describe how each may contribute to the degradation of a theoretically perfect image.
- (iii) Since the first introduction of a commercial scintillation camera in 1963 a number of technological improvements have been made. What are they and what has been their impact on total system performance?
- (iv) The most recent innovation has been the introduction of "digital" scintillation cameras. In what manner are these cameras different from the traditional analog design? What advantages are gained by using such a design? What are the inherent disadvantages of a "digital" scintillation camera?



C.9 PHYSICS OF NUCLEAR MEDICINE

- (i) Describe the essential features of a system used for gamma-ray spectroscopy.
- (ii) Scintillation detectors have a relatively poor energy resolution. As a consequence, semiconductor detectors have been introduced to improve the resolving power of gamma spectrometers. Discuss at least two types of semiconductor detectors used in gamma spectrometry. Why are they not used more routinely in nuclear medicine applications?
- (iii) Describe a system that may be used to image the I-127 content of the thyroid.
- (iv)
 - (a) Describe those factors that contribute to dead-time,
 - (b) define "paralyzable" and "non-paralyzable",
 - (c) describe one method by which dead-time may be determined.
- (v) Sketch and describe the changes in a differential pulse-height spectrum (energy spectrum) for Cr-51 (320 keV) if:
 - (a) a larger NaI (Tl) crystal were used
 - (b) a one-inch slab of lucite were interposed between the Cr-51 source and the NaI scintillation detector
 - (c) a one-inch slab of lucite were placed behind the Cr-51 source.
- (vi) A source is to be counted in the presence of background (T , or total counts) and taken for the background alone (B). If σ_T and σ_B are the respective standard deviations, derive an expression for the standard deviation (σ) of the net counting rate. How should the time available for counting be optimally divided between the two measurements?



Wayne State University
School of Medicine

C.10 PHYSICS OF NUCLEAR MEDICINE

- (i) Describe the underlying principles of single photon emission computed tomography (SPECT) using a rotating scintillation camera. How does this method compare to limited angle tomography ?**
- (ii) Some greater constraints must be placed upon the system performance to produce high quality tomographic images. What are these constraints and what quality control procedures must be introduced to ensure that performance is maintained ?**
- (iii) Describe at least three possible sources of image artifact. Sketch how these might appear in a liver tomogram and describe how they may be avoided.**
- (iv) Attenuation correction is an important aspect of tomographic reconstruction techniques. Why is this so, how is it achieved, and why is the attenuation factor, that is used, usually less than the linear attenuation coefficient for that photon energy in tissue ?**



Wayne State University
School of Medicine

c.11 PHYSICS OF NUCLEAR MEDICINE

- (i) Briefly define the following NEMA (National Electrical Manufacturers Association) terms as appropriate for a scintillation camera:
- | | |
|--------------------------------------|--|
| (a) intrinsic spatial resolution | (e) intrinsic count rate performance |
| (b) intrinsic energy resolution | (f) multiple window spatial registration |
| (c) intrinsic flood field uniformity | (g) system sensitivity |
| (d) intrinsic spatial linearity | (h) system spatial resolution with and without scatter |
- (ii) Describe the historical evolution of the scintillation camera in terms of intrinsic spatial resolution and intrinsic flood field uniformity. Be sure to include in your analysis a plot of these values as a function of the year from 1970 to the present.
- (iii) Describe the effects of crystal thickness on intrinsic spatial resolution, system spatial resolution without scatter, and system sensitivity for Tc-99m and I-131.
- (iv) What are the sources of intrinsic flood field non-uniformity? With reference to three manufacturers discuss recent innovations in design introduced to correct for such scintillation camera defects.
- (v) What scintillation camera performance parameters are most important for the following clinical applications:
- liver tomography
 - cardiology



Wayne State University
School of Medicine

C.12 PHYSICS OF NUCLEAR MEDICINE

Radioactive calcium can be used for metabolic bone studies. It was routine in your laboratory to give 1 MBq of Ca-47. However, you are now asked to switch to Ca-45 because of its increased availability.

- (i) Making reference to the decay schemes of Ca-47 and Ca-45, calculate the relative radio-toxicity of these two isotopes. Make reasonable assumptions regarding the biological half-life of calcium. Based on your calculation what would the equivalent dose of Ca-45 be as compared to a dose of 1 MBq of Ca-47 ?
- (ii) Using the formulation of the MIRD of the Society of Nuclear Medicine, calculate the radiation dose from 100 kBq of Ca-45 to the bone marrow. Assume 3000 g as the weight of the bone marrow. Consider only decay processes which occur during more than 1% of Ca-45 decays.
- (iii) How do you amend your radio-isotope licence so that you can order Ca-45 ?
- (iv) When the first delivery of Ca-45 is made to your laboratory, how will you determine the quantity which has been delivered and its radionuclidic purity ?
- (v) How is Ca-45 produced ?

Note: The decay schemes of Ca-45 and Ca-47 taken from the MIRD pamphlets will be provided as reference material if this question is asked on the examination.



Wayne State University
School of Medicine

D.1 RADIOLOGICAL PHYSICS

- (i) Briefly define or explain:
- | | |
|----------------------------------|------------------------------|
| (a) photoelectron | (f) characteristic radiation |
| (b) Compton wavelength | (g) ion pair |
| (c) Auger effect | (h) electron-hole pair |
| (d) internal conversion electron | (i) recoil electron |
| (e) annihilation quantum | (k) absorption edge |
- (ii) Five basic ways in which an x-ray photon can interact with matter are listed below. Briefly discuss the five effects and identify the ones which are of importance in diagnostic radiology:
- | | |
|--------------------------|-------------------------|
| (a) coherent scattering | (d) pair production |
| (b) photoelectric effect | (e) photodisintegration |
| (c) Compton effect | |
- (iii) Four factors determine the degree of attenuation of an x-ray beam as it passes through matter. These are the photon energy and the density, atomic number and electron density of the absorber. Discuss how these four factors affect the first four effects in (ii).
- (iv) Define kerma K and absorbed dose D . For a monoenergetic photon beam express K and D in terms of photon fluence ϕ and the mass attenuation coefficient μ/ρ . Show that K and D may also be expressed in terms of the photon energy fluence ψ and the mass energy transfer μ_{tr}/ρ and mass energy absorption μ_{ab}/ρ coefficients respectively.
- (v) Give the maximum energy transferred to the electron for the first four effects discussed in (ii). For Compton effect sketch the maximum and average energy given to Compton recoil electron (normalized to incident photon energy) as a function of photon energy in the photon energy range from 10 keV to 100 MeV.



Wayne State University
School of Medicine

D.2 RADIOLOGICAL PHYSICS

(I) Briefly define or explain:

- | | |
|---------------------------------|------------------------------|
| (a) activity A | (f) half-life $t_{1/2}$ |
| (b) specific activity a | (g) mean lifetime τ |
| (c) carrier-free source | (h) decay constant λ |
| (d) branching ratio | (i) decay chain |
| (e) energy level width Γ | (k) daughter activity |

(ii) For a typical radioactive nucleus sketch graphs relating activity to time t on (a) a semi-log plot, and (b) a linear plot.

Show $t_{1/2}$ and τ on the abscissa and calculate the relationship between τ , λ and $t_{1/2}$.

(iii) Consider the two-step process in which a radioactive parent nuclide P decays to an unstable daughter nuclide D , which in turn decays to a stable granddaughter nuclide G :



Represent the number of parent, daughter and granddaughter nuclei present at some arbitrary time $t > 0$ by P , D and G . Assume that at $t = 0$, $P = P_0$ and $D = D_0 = G = G_0 = 0$.

(a) Derive the general relationship for $D(t)$ in terms of $P(t)$ and the decay constants λ_P and λ_D .

(b) Sketch the activities A_P and A_D vs time t for a typical example where $\lambda_P < \lambda_D$. Calculate the time t_{\max} for the maximum in daughter activity and show that this occurs when both the parent and the daughter have the same activity. Show that for $\lambda_P \approx \lambda_D$, t_{\max} may be expressed as $t_{\max} \approx (\lambda_P \lambda_D)^{-0.5}$. Assume $\lambda_P = \lambda_D (1 - \epsilon)$, where $\epsilon \ll 1$.

(iv) Sketch and compare activity curves A_P and A_D vs t for the following conditions:

(a) $\lambda_P > \lambda_D$, short lived parent, (b) $\lambda_P < \lambda_D$, long lived parent, (c) $\lambda_P \ll \lambda_D$, very long lived parent, and (d) $\lambda_P \ll t \ll \lambda_D$, almost stable or constantly replenished parent. Define transient and secular equilibrium.



Wayne State University
School of Medicine

D.3 RADIOLOGICAL PHYSICS

(i) Briefly define or explain:

- | | |
|--------------------------|----------------------------------|
| (a) neutron activation | (f) fission fragments |
| (b) isomeric transition | (g) nuclear chain reaction |
| (c) neutron fluence rate | (h) moderator in nuclear reactor |
| (d) annihilation photon | (j) artificial radioactivity |
| (e) specific ionization | (k) natural radioactivity |

(ii) Discuss the interactions of the particles listed below with matter in general and tissue in particular.

- alpha particles (kinetic energy: few MeV)
- beta particles (kinetic energy: few MeV)
- thermal neutrons
- fast neutrons.

(iii) Nuclide A is bombarded by neutrons with a fluence rate ϕ ($\text{cm}^{-2}\text{s}^{-1}$) and an unstable nuclide B is produced. The cross-section for the reaction is σ (cm^2). Nuclide B decays with a decay constant λ_B into a stable nucleus C: $A \xrightarrow{\sigma\phi} B \xrightarrow{\lambda_B} C$. The activity $A_B(t)$ is usually given as: $A_B(t) = A_s (1 - \exp(-\lambda_B t))$, where $A_s = \sigma\phi N_A(0)$ is called the saturation activity and an assumption is made that $\lambda_B \gg \sigma\phi = 0$.

- derive a relationship for $A_B(t)$ for situations in which the above assumption is not valid and show that this general relationship transforms into $A_B(t) = A_s (1 - \exp(-\lambda_B t))$ for $\lambda_B \gg \sigma\phi = 0$.
- show that the time t_{\max} for maximum activity of nuclide B is given by:
$$t_{\max} = (\lambda_B - \sigma\phi)^{-1} \ln(\lambda_B / \sigma\phi).$$

(iv) When a radioactive nuclide has a daughter of shorter half-life, it is often possible to separate the two, mechanically or chemically. Several such systems, known as nuclear generators, are in use. Name at least three such systems and sketch the activity of parent and daughter:

- with no removal of daughter, (b) with periodic removal of the daughter.



Wayne State University
School of Medicine

D.4 RADIOLOGICAL PHYSICS

- (I) Briefly define or explain:
- | | |
|----------------------------|-------------------------------|
| (a) nuclear excited state | (f) annihilation quantum |
| (b) atomic excited state | (g) internal conversion yield |
| (c) fluorescence yield | (h) characteristic radiation |
| (d) average β energy | (i) bremsstrahlung |
| (e) isomeric state | (k) mass deficit |
- (ii) Discuss α decay in general, give the general relationship for the total energy Q_α liberated in α decay and sketch an energy level diagram for a typical α decay.
- (iii) Use the invariant $E^2 - p^2c^2 = \text{inv}$ to derive a general relationship for threshold in a nuclear reaction $A(a, b)B$, where a is the projectile.
- (iv) Use the general relationship derived in (iii) to show that the threshold E
- for the photodisintegration of deuteron is $E_\gamma = E_B (1 + E_B/2 m_d c^2)$, and
 - for the pair production in the field of nucleus is $E_\gamma = 2 m_e c^2 (1 + m_e c^2/m_A c^2)$, where E_B is the deuteron binding energy and $m_d c^2$, $m_A c^2$ and $m_e c^2$ are the rest energies of the deuteron, nucleus, and electron respectively.
- (v) Sketch and briefly discuss the curve E_B/A vs A , where E_B is the total binding energy of any nucleus and A is its atomic mass. Indicate and briefly discuss the regions representing fusion and fission on the curve.



Wayne State University
School of Medicine

D.5 RADIOLOGICAL PHYSICS

(i) Briefly define or explain:

- | | |
|------------------------------------|--|
| (a) nuclear resonance fluorescence | (f) Cerenkov radiation |
| (b) gamma ray spectroscopy | (g) internal conversion coefficient |
| (c) Mossbauer effect | (h) Auger electrons |
| (d) characteristic x ray | (i) mass energy absorption coefficient |
| (e) triplet production | (k) threshold for nuclear reaction |

(ii) Discuss the gamma decay in general, give a typical example with an energy level diagram and explain the internal conversion and isomeric transitions.

(iii) An electron beam with kinetic energy of 10 MeV impinges onto a thick lead target. Explain what type of radiation is produced in the target and sketch the energy spectrum and angular distribution.

(iv) Sketch a diagram representing the three most important modes of photon interactions with a medium, briefly discuss the three effects, and state the dependence of the appropriate mass attenuation coefficient upon the photon energy and atomic number of the medium.

(v) On a graph exhibiting atomic number Z vs log photon energy, sketch two curves: one giving equal probability for photoeffect and Compton effect, and the other equal probability for Compton effect and pair production.



Wayne State University
School of Medicine

D.6 RADIOLOGICAL PHYSICS

- (i) Define attenuation and absorption coefficients for photon beams and discuss the difference between the two coefficients.
- (ii) Prepare a table showing the relationship between the linear, mass, atomic and electronic attenuation coefficients and show suitable units of these coefficients.
- (iii) Define the mass energy transfer and mass energy absorption coefficient, discuss the relationship of these two coefficients with the mass attenuation coefficient, express kerma and absorbed dose in terms of the mass energy transfer coefficient and mass energy absorption coefficient respectively, and discuss the conditions under which these relationships are valid.
- (iv) Briefly discuss the various types of interactions contributing to the mass attenuation coefficient. Sketch the mass attenuation coefficient for water and lead on a log-log graph in the energy range from 10 keV to 100 MeV indicating the regions where a certain type of interaction predominates.
- (v) On a graph exhibiting atomic number Z vs log photon energy sketch two curves, one giving equal probability for photo-effect and Compton effect and the other equal probability for Compton effect and pair production.
- (vi) On a log-log graph sketch, for air, the mass attenuation coefficient μ/p , mass energy transfer coefficient μ_{tr}/p , and mass energy absorption coefficient μ_{en}/p in the photon energy range from 10 keV to 100 MeV.



Wayne State University
School of Medicine

D.7 RADIOLOGICAL PHYSICS

- (i) Briefly define or explain:
- | | |
|-------------------------|--------------------------------|
| (a) fluorescent yield | (f) Klein-Nishina coefficients |
| (b) Auger effect | (g) photoelectrons |
| (c) internal conversion | (h) triplet production |
| (d) K-edge | (j) annihilation photon |
| (e) Rayleigh scattering | (k) characteristic radiation |
- (ii) Sketch a diagram representing the three most important modes of photon interactions with a medium, briefly discuss the three effects and state the dependence of the appropriate attenuation coefficient upon the photon energy and atomic number of the medium.
- (iii) Briefly discuss the processes that follow the three modes of interactions in (ii).
- (iv) For Compton effect, state the three relativistic equations which represent the conservation of energy and momentum and are used in the derivation of the Compton relationship
- $$\lambda' - \lambda = \lambda_c (1 - \cos \theta).$$
- (v) Using the Compton relationship derive expressions for the energy of the scattered photon and the kinetic energy of the recoil electron. Show that the maximum energy of the backscattered photon is equal to 255 keV irrespective of the incident photon energy.
- (vi) At a photon energy $h\nu$ of 4 MeV in lead, the atomic attenuation coefficients for photoeffect τ , Compton effect σ and pair production κ are $0.567 \cdot 10^{-24}$ cm²/atom, $7.878 \cdot 10^{-24}$ cm²/atom, and $5.782 \cdot 10^{-24}$ cm²/atom, respectively. Calculate the mass attenuation coefficient μ/ρ , the mass energy transfer coefficient μ_{tr}/ρ , and the mass energy absorption coefficient μ_{ab}/ρ (the bremsstrahlung fraction g is 0.130). Clearly explain the steps involved in the calculation.



Wayne State University
School of Medicine

D.8 RADIOLOGICAL PHYSICS

- (i) Define the stopping powers attributed to ionizational and radiation losses and discuss the difference between the stopping power and linear energy transfer (LET).
- (ii) Use principles of classical mechanics to derive an expression for the mass ionizational stopping power S_{ion} for a heavy charged particle interacting with orbital electrons in a medium. Discuss the role of I , the mean excitation energy of the atom, in the Heitler's quantum mechanical derivation of S_{ion} .
- (iii) Discuss the differences between Heitler's derivation of S_{ion} for heavy charged particles and Bethe's derivation of S_{ion} for electrons. Describe the energy and atomic number dependence of S_{ion} for electrons in the energy range from 10 keV to 100 MeV and sketch S_{ion} for electrons in water and lead in the same energy range.
- (iv) Discuss the energy and atomic number dependence of the radiation loss stopping power S_{rad} for electrons in the energy range from 10 keV to 100 MeV and sketch S_{rad} for electrons in water and lead on the diagram in (iii).
- (v) Define the mean ionizational stopping powers for the following situations:
 - (a) monoenergetic electrons set in motion in medium
 - (b) electrons with a distribution of initial energies such as are produced by monoenergetic photons
 - (c) electrons with a distribution of initial energies such as are produced by a spectrum of photon energies



Wayne State University
School of Medicine

D.9 RADIOLOGICAL PHYSICS

- (i) A photon of energy $h\nu$ interacts with lead:
- give the general relationship between $h\nu$ and the maximum kinetic energy E_{max} of the free electron produced through photoeffect, Compton effect or pair production;
 - Assume $h\nu = 2 \text{ MeV}$. Calculate E_{max} for the three effects.
- (ii) Plot a graph showing the maximum and the average kinetic energy of a Compton recoil electron as a function of photon energy $h\nu$ in the energy range from 10 keV to 100 MeV.
- (iii) The Klein-Nishina formula relating the Compton differential cross-section $d_{\theta}\sigma_c/d\Omega$ with the photon scattering angle θ is given by:

$$\frac{d_{\theta}\sigma_c}{d\Omega} = \frac{r_0^2}{2} \times \frac{1 + \cos^2\theta}{[1 + \alpha(1 - \cos\theta)]^2} \times \left\{ 1 + \frac{\alpha^2 (1 - \cos\theta)^2}{[1 + \cos^2\theta][1 + \alpha(1 - \cos\theta)]} \right\}$$

where $r_0 = 2.8 \text{ fm}$ is the classical electron radius and $\alpha = h\nu/m_0c^2$ with $m_0c^2 = 0.511 \text{ MeV}$.

Show that for $\alpha = 0$ and any θ , and for $\theta = 0$ and any α , $d_{\theta}\sigma_c/d\Omega$ transforms into the classical scattering coefficient per electron $d_{\theta}\sigma_0/d\Omega$. Integrate $d_{\theta}\sigma_0/d\Omega$ over $d\Omega$ to get $\sigma_0 = 66.5 \cdot 10^{-30} \text{ m}^2$. Plot $d_{\theta}\sigma_c/d\Omega$ vs θ for photon energies $\sim 0, 1 \text{ MeV}$ and 10 MeV .

- (iv) From $d_{\theta}\sigma_c/d\Omega$ given in (iii) calculate the differential cross-section $d_{\theta}\sigma_c/dE$, which gives the number of Compton collisions that lead to electrons with kinetic energies in the range E to $E + dE$, to get:

$$\frac{d_{\theta}\sigma_c}{dE} = \frac{3}{8} \frac{\sigma_0}{\alpha h\nu} \times \left\{ 2 - \frac{2E}{\alpha(h\nu - E)} + \frac{E^2}{\alpha^2(h\nu - E)} + \frac{E^2}{h\nu(h\nu - E)} \right\}$$

Plot this relationship as a function of the electron kinetic energy E for photon energies $h\nu$ of 0.5 MeV and 1 MeV .

- (v) Using the invariant $E^2 - p^2c^2 = \text{inv}$ calculate the thresholds for pair production and triplet production.



Wayne State University
School of Medicine

D.10 DOSIMETRY

(i) Briefly define or explain:

- | | |
|--------------------------------|--|
| (a) 1 Roentgen | (f) mass energy attenuation coefficient |
| (b) electronic equilibrium | (g) beam defining diaphragm |
| (c) W for air | (h) chamber temperature and pressure correction factor |
| (d) polarizing electrode | (i) collection efficiency |
| (e) chamber calibration factor | (k) initial and general recombination |

(ii) Define exposure and show that 1 R corresponds to an absorbed dose in air of 0.873 cGy.

(iii) Derive the expression relating absorbed dose D_{med} to exposure X at a point in medium, given as:

$$D_{\text{med}} = X f_{\text{med}}$$

where f_{med} is the R to cGy conversion factor. Plot f_{med} vs photon energy for bone, muscle and air, in the photon energy range from 10 keV to 10 MeV.

- (iv) The most common technique for measurement of exposure is based on calibrated ionization chambers. The calibration factors for these chambers are usually obtained from National Standardization Laboratories which use standard free air ionization chambers for absolute calibrations.
- Sketch a standard free air ionization chamber and an associated simple electronic circuit, clearly label its components and discuss its operation;
 - Sketch a typical thimble ionization chamber and discuss the effect of wall material and wall thickness on the exposure measurement;
 - Sketch a typical saturation curve for an ionization chamber and discuss its behavior.
- (v) Discuss at least two other techniques which are routinely used for exposure calibration of diagnostic x-ray beams.



Wayne State University
School of Medicine

A.1 PHYSICS OF RADIATION ONCOLOGY

(i) With a simple diagram illustrate the two steps involved in energy transfer from a photon to the medium and clearly define the following:

- | | |
|----------------------------|-----------------------------|
| (a) kerma | (f) bremsstrahlung |
| (b) absorbed dose | (g) Auger electron |
| (c) exposure | (h) delta rays |
| (d) electronic equilibrium | (j) fluorescent yield |
| (e) conversion electrons | (k) effective atomic number |

(ii) Write kerma and absorbed dose in terms of the photon energy fluence and mass attenuation coefficients both for a homogeneous photon beam with energy $h\nu$ and for a heterogeneous photon spectrum with maximum energy $h\nu_{\max}$.

(iii) Briefly discuss the Bragg-Gray cavity theory and clearly define the parameters involved.

(iv) Discuss the method to measure dose in a medium using a cavity ionization chamber with a wall material different from the material of medium. Clearly define the steps involved and identify any approximations.

(v) Define the "dose in free space" and explain the situations for which this parameter is useful in radiotherapy.

(vi) Discuss the method to determine dose in a medium using an exposure calibrated ionization chamber.



Wayne State University
School of Medicine

A.2 PHYSICS OF RADIATION ONCOLOGY

- (i) Draw a schematic diagram of a typical x-ray tube with associated electronics, used in radiotherapy and clearly label the components. Discuss several methods for voltage rectification and briefly state the main differences between therapy and diagnostic radiology x-ray tubes.
- (ii) Treatment times on x-ray machines and cobalt machines are usually controlled by an electrically driven timer which is started by the switching-on of the beam and which ends the exposure at some preset time. Discuss the shutter error associated with the timer, explain a method for its measurement on a given machine, and explain how it is used in setting the treatment times in practice.
- (iii) Betatrons and microtrons are used in some therapy departments for photon and electron therapy. Show the two machines schematically. Briefly discuss their mode of operation and consider the advantages and disadvantages of the two machines over the linear accelerators.
- (iv) Discuss the role and typical properties of targets and flattening filters used in linacs and betatrons in the production of clinical x-ray beams. Also discuss the methods used to produce a clinical electron beam from the pencil beam which exits the linac or betatron.



Wayne State University
School of Medicine

A.3 PHYSICS OF RADIATION ONCOLOGY

- (I) Illustrate two different methods used to bring a source into ON position on a radiotherapy isotope machine. Also sketch a standard isotope source capsule with typical dimensions.
- (II) Radium-226, Cesium-137, Iridium-192 and Cobalt-60 are isotopes used in brachytherapy. Photon energy, specific source activity, half-life and means of production are the parameters determining the usefulness of a given radioisotope for radiotherapy.

Discuss the advantages and disadvantages of each of the four isotopes when used in brachytherapy.

- (III) Calculate the maximum activity that can be produced in 10 g of ^{59}Co when it is irradiated in a neutron fluence rate ϕ of $10^{13}\text{cm}^{-2}\text{s}^{-1}$. The atomic weight of cobalt is 58.94, and the activation cross section is $\sigma=37$ barns/atom. First calculate the time t_{max} in which the maximum activity of cobalt-60 will be achieved. Do not assume in your derivation that $\lambda(^{60}\text{Co}) \gg \sigma \cdot \phi \approx 0$.
- (IV) Cobalt units can be calibrated either in air by exposure measurements or in water by measurement of ionization in a calibrated ionization chamber. Discuss in detail the two calibration options and indicate how they are related to each other.



Wayne State University
School of Medicine

A.4 PHYSICS OF RADIATION ONCOLOGY

- (i) Compare the power delivered to the target of an x-ray tube operated at 100 kVp/50 mA/3 phase 12 pulse rectified, to the power delivered to the target of a 20 MV linac operated at 50 pps with an electron current pulse width of 2 μ s and a height of 50 mA.
- (ii) Discuss the radiation protection considerations for 25 MV linear accelerator to be used in the photon (25 MV) and electron mode (6 MeV / 30 MeV). Consider the following:
 - (a) government regulations and regulatory agencies;
 - (b) room design to accept standard radiotherapy procedures as well as options for intraoperative radiotherapy, total body electron irradiations and total body photon irradiations;
 - (c) instrumentation and procedures for making the radiation survey, including a neutron survey and a survey to evaluate the production of radioactive gases and ozone.
- (iii) Discuss in detail the measurements which a medical physicist should perform on a linear accelerator (calibration and acceptance testing) before it is accepted and put into clinical operation (photons and electrons).
- (iv) Discuss in detail the measurements a physicist should perform around a linear accelerator installation (radiation survey of installation) before the machine is put into clinical operation (photons and electrons).



A.5 PHYSICS OF RADIATION ONCOLOGY

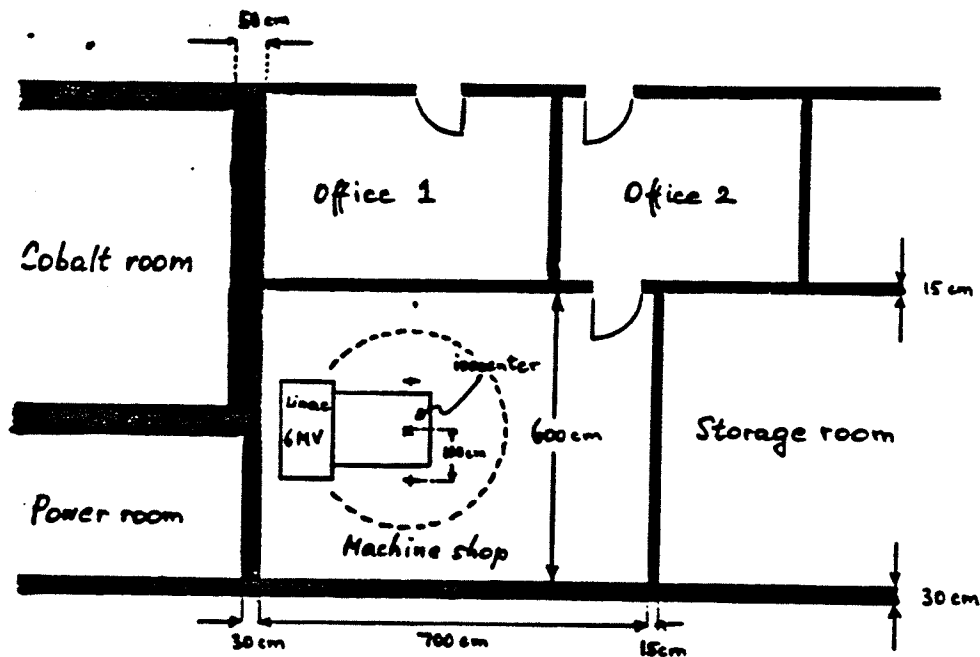

- (i) A new 6 MV isocentric accelerator without a beam stopper is to be installed in the room presently occupied by a machine shop as shown on the sketch above. The room is in a basement and there are operating theatres above. The existing dimensions of the room and wall thicknesses are given on the sketch. Maximum field size at an SAD of 100 cm is 40-40 cm². The ceiling is 4 m high and the ceiling slab is 15 cm of concrete. Assume that 25 patients will be treated daily. Prepare and sketch the necessary reconstruction information for the architect on:
- proposed machine position in the room,
 - position and thickness of a maze if required,
 - total and additional thicknesses of walls and ceiling,
 - safety and accessory features to be installed in the room,
 - thickness and position of the door.
 - Would the reconstruction plan be any different if the treatment machine in addition to 6 MV photons has a 6 MeV electron capability?
 - Show the saving in wall and ceiling thickness if the machine is purchased with a beam stopper.
- (ii) Discuss the area radiation survey procedure that should be performed after the room is reconstructed and the treatment unit is installed and operational. List the equipment to be used in the survey and suggest some typical measurement results for the installation.



Wayne State University
School of Medicine

A.6 PHYSICS OF RADIATION ONCOLOGY

- (I) Draw a schematic diagram of a high energy electron linear accelerator and clearly label the components.
- (II) Give a range of values and units for the following parameters of a typical linear accelerator:
- | | |
|---------------------------------|---|
| (a) peak beam current | (f) beam current pulse width |
| (b) average beam current | (g) electron gun voltage |
| (c) modulator pulse width | (h) length of accelerating waveguide |
| (d) peak modulator current | (i) target material and thickness in a
25 MV Linac |
| (e) radiofrequency of operation | (j) electron kinetic energy in the wave-
guide |
- (III) Sketch the E field motion in:
- a uniform waveguide and
 - a disk-loaded waveguide
- and discuss the phase and group velocity for the two types of waveguides.
- (IV) Discuss the disk-loaded waveguide in particle acceleration.
- (V) Show that particle velocity should equal phase velocity for acceleration in a linac.



A.7 PHYSICS OF RADIATION ONCOLOGY

(I) Briefly define or explain:

- | | |
|--------------------------|---------------------------|
| (a) isocenter | (f) surface dose |
| (b) AP/PA | (g) build-up region |
| (c) output factor OF | (h) depth of dose maximum |
| (d) collimator factor CF | (j) SSD |
| (e) exit dose | (k) SAD |

(II) Define the following functions used in radiation therapy dose calculations, sketch the relevant geometry and clearly state what beam parameters the functions are influenced by:

- | | |
|------------------------------|-------------------------------------|
| (a) percentage depth dose P | (e) scatter-air ratio SAR |
| (b) tissue-air ratio TAR | (f) scatter maximum ratio SMR |
| (c) tissue-maximum ratio TMR | (g) zero area percentage depth dose |
| (d) tissue-phantom ratio TPR | (h) primary beam |

(III) Sketch the following percentage depth doses P in water:

- 100 kVp, cobalt, and 10 MV x ray: P as a function of depth for a $10 \times 10 \text{ cm}^2$ field with SSD 100 cm
- SSD 80 cm and SSD 120 cm: P as a function of depth for a cobalt beam with a field of $10 \times 10 \text{ cm}^2$
- cobalt beam and 250 kVp, 4 MV, 6 MV, 10 MV and 25 MV x rays: P as a function of beam effective energy at a depth of 5 cm with a field of $10 \times 10 \text{ cm}^2$.

(IV) Sketch TAR and TMR as a function of depth in water for a cobalt beam, $10 \times 10 \text{ cm}^2$ field size.

(V) Derive the following relationships:

- between P and TAR, (b) between S and SAR, (c) between TAR and TMR
- Make sketches and clearly identify the steps involved in the derivations.

(VI) Briefly discuss at least three methods for heterogeneity corrections in dose calculations with photon beams.

A.8 PHYSICS OF RADIATION ONCOLOGY

(i) Briefly define or explain :

- | | |
|---|---------------------------------|
| (a) kinetic energy of electrons | (f) stopping power ratio |
| (b) electron fluence | (g) Cerenkov radiation |
| (c) delta rays | (h) Fricke dosimetry |
| (d) practical range of electrons | (j) G-value |
| (e) secondary electrons | (k) calorimetry |

- (ii) Discuss at least three techniques which may be used to determine the kinetic energy of an electron beam impinging onto a phantom. Define energies for which the methods are applicable.**
- (iii) Sketch percentage depth dose and isodose distributions for a typical 10-10 cm² electron beam with initial kinetic energies of 6, 15 and 25 MeV.**
- (iv) Briefly discuss the method for absorbed dose measurement in an electron beam with an ionization chamber. Clearly define the parameters used.**
- (v) Briefly discuss the missing tissue and the inhomogeneity corrections for electron beams.**
- (vi) Briefly discuss mycosis fungoides, its clinical manifestations, course and currently used treatment modalities. Total skin electron irradiation (TSEI) is a proven treatment modality. Discuss in detail the changes and measurements that should be made on a standard linear accelerator before it can be applied for TSEI. Also discuss a few treatment techniques currently employed for TSEI in various centers. State typical doses and fractionations used.**



Wayne State University
School of Medicine

A.9 PHYSICS OF RADIATION ONCOLOGY

- (I) Interest in afterloading in brachytherapy has grown in recent years with the development of sophisticated interstitial techniques and remote intracavitary systems. Explain fully why afterloading is advantageous and point out improvements possible with remote afterloading.
- (II) Remote afterloading in gynecological brachytherapy opens the door to high dose rate therapy. What could be the advantages and possible disadvantages of such an approach? How can doses delivered at high dose rate be compared with previously used doses delivered at low dose rate?
- (III) Describe an afterloading technique for implanting ^{192}Ir sources for endobronchial or cervix cancer treatments.
- (IV) A variety of sources is used in afterloaders and these often differ markedly in size and shape from traditional ^{226}Ra sources. Discuss the practical problem of source calibration. In terms of what quantities could a source be calibrated? Suggest two alternative ways of obtaining an accurate calibration value for a set of spherical 2.5 mm diameter ^{137}Cs sources in a newly installed unit (400 MBq approximate activity).



Wayne State University
School of Medicine

A.10 PHYSICS OF RADIATION ONCOLOGY

(i) Briefly define or explain :

- | | |
|--------------------------|--------------------------------|
| (a) wedge filters | (f) tray factor |
| (b) compensating filters | (g) laser alignment devices |
| (c) bolus | (h) optical distance indicator |
| (d) lung shielding | (i) shielding block |
| (e) wedge factor | (k) immobilization device |

(ii) State and briefly discuss the therapeutic modalities available for treatment of carcinoma of the breast. Discuss in detail a standard radiation treatment of the breast or chest-wall, its main problems and some technical innovations that have recently been proposed to solve the problems. Also state the typical total dose and fractionation used.

(iii) It is now generally accepted that radiation therapy is the treatment of choice for Hodgkin's disease in early stages. Discuss in detail the technique of irradiation, the treatment prognosis, the total dose and fractionation used.

(iv) The justification of radiotherapy for carcinoma of the larynx and hypopharynx lies in its ability to cure and yet preserve function. Discuss in detail the irradiation techniques used in treatment of carcinoma of the larynx and state the total dose, fractionation and dose-time relationship used.



Wayne State University
School of Medicine

A.11 PHYSICS OF RADIATION ONCOLOGY

- (I) There is a growing trend towards the use of total body irradiation (TBI) with photon beams prior to bone marrow transplantation (BMT) for leukemic patients. Discuss the rationale for TBI prior to BMT, the dose regimen usually given, the medical problems encountered during or after TBI, as well as the theoretical advantages or disadvantages of delivering the dose in a single fraction as compared to multiple fractions.
- (II) Briefly discuss at least two different methods used in various treatment centers for production of large photon fields for TBI.
- (III) Discuss the dosimetric measurements that must be performed by a medical physicist before a standard therapy unit can be applied for TBI with photon beams.
- (IV) Briefly discuss the following:
 - (a) ALL
 - (b) radiation "sickness"
 - (c) blood counts
 - (d) pneumonitis
 - (e) extended SSD treatment
 - (f) renal shielding
 - (g) partial lung shielding
 - (h) aplastic anemia
 - (i) use of CT for determination of lung dose
 - (j) methods for lung dose reduction in TBI



Wayne State University
School of Medicine

A.12 PHYSICS OF RADIATION ONCOLOGY

Conventional radiotherapy is performed with photon and electron beams; there are, however, other directly or indirectly ionizing particles, such as protons, pions, heavy ions and neutrons, that have been used or proposed for cancer therapy. State the rationale for use of these particles and briefly describe the physical effects they produce in tissue.

(II) Briefly define or explain:

- | | |
|--|---|
| (a) Bragg peak | (f) Coulomb interaction |
| (b) rest masses of negative pion, neutron and proton | (g) characteristic mesic x rays |
| (c) ionizational stopping power | (h) star formation |
| (d) radiation loss | (i) approximate range of a 50 MeV π^- in tissue |
| (e) elastic scattering | (j) approximate range of a 100 MeV - proton in tissue |

(III) Two types of machines (D-T generators and cyclotrons) are used for production of neutron beams in radiotherapy. Draw a schematic diagram of the two machines, clearly label the components, and explain the basic physical processes in neutron production.

(IV) Briefly discuss the production of proton and pion beams in radiotherapy. Also discuss the difference between interactions with tissue of a high energy proton and a negative pion. Why are positive pions not suitable for radiotherapy?

(V) Plot a percentage depth dose curve for a 14 MeV neutron beam in water and compare it to a percentage depth dose curve for a typical cobalt beam.

(VI) Plot percentage depth dose curves for a 100 MeV proton beam and a 50 MeV negative pion beam in water and explain the procedure employed to make the beam useful in radiotherapy.



B.1 PHYSICS OF DIAGNOSTIC RADIOLOGY

(i) Briefly define or explain:

- | | |
|--------------------------|--------------------------------|
| (a) thermionic emission | (f) rotating anode |
| (b) field emission | (g) saturation voltage |
| (c) space charge effect | (h) heel effect |
| (d) focusing cup | (j) heat unit |
| (e) line focus principle | (k) grid controlled x-ray tube |

(ii) Draw a schematic diagram of a typical x-ray tube with the associated filament and high voltage circuitry providing single phase rectification. Clearly label the components.

(iii) Discuss in detail the two types of x rays produced when an electron beam with a given kinetic energy impinges onto a tungsten target.

(iv) An electron beam with a given kinetic energy E_k impinges onto a target. Sketch and compare the spectra and photon angular distributions for the following conditions:

- $E_k = 100$ keV, tungsten target vs molybdenum target,
- tungsten target, $E_k = 100$ keV vs $E_k = 5$ MeV,
- tungsten target, $E_k = 100$ keV vs electrons accelerated in a 100 kVp self-rectified x-ray tube.

(v) Discuss heat production and distribution in x-ray tubes and explain how the anode design and kilovoltage waveform affect the operation of the tube. Sketch a typical x-ray tube rating chart and, on another diagram, typical anode heating and cooling curves.

(vi) The rate at which heat is produced in the focal spot area of an x-ray tube is given by:

$$P(W) = kVp \cdot ma \cdot w,$$

where w is the waveform factor. Give w for (a) constant potential, (b) 3 phase/12 pulse, (c) 3 phase/6 pulse, and (d) single phase.

Also give the relationship between heat measured in heat units and in joules.



Wayne State University
School of Medicine

B.2 PHYSICS OF DIAGNOSTIC RADIOLOGY

- (i) Briefly define or explain:
- | | |
|--------------------------------|---|
| (a) mechanical x-ray switch | (e) spinning top used to check timer accuracy |
| (b) thyatron | (f) voltage ripple |
| (c) grid-controlled x-ray tube | (g) rotating anode |
| (d) silicon controlled switch | (h) waveform factor |
- (ii) Discuss x-ray switches (mechanical and electronic) and x-ray timers (mechanical, synchronous, electronic and phototiming).
- (iii) Draw a diagram relating x-ray tube current with anode voltage for two filament temperatures, T_1 and T_2 with $T_1 < T_2$. Explain the particular curve behavior.
- (iv) Discuss and show schematically various methods for reaching the high anode voltages in x-ray units:
- | | |
|---|--|
| (a) self-rectified circuits | (e) full-wave rectified/3 phase/12 pulse |
| (b) half-wave rectified/single phase | (f) constant potential |
| (c) full-wave rectified/single phase | (g) capacitor discharge |
| (d) full-wave rectified/3 phase/6 pulse | (h) medium and high frequency generators |

For each method above also sketch the anode voltage as a function of time and prepare a table giving the ripple factor in per cent of maximum voltage



B.3 PHYSICS OF DIAGNOSTIC RADIOLOGY

(i) The attenuation of x rays in the body can be presented in the form of percentage depth dose curves for beam central axes and with isodose distributions similar to those used in radiotherapy for planes containing the beam central axis. Define percentage depth dose and isodose distributions in general and sketch the percentage depth dose distributions for the following beams:

- | | |
|--------------------------|-------------------------|
| (a) 50 kVp, SSD = 50 cm | (d) Cobalt, SSD = 80 cm |
| (b) 80 kVp, SSD = 50 cm | (e) 10 MV, SSD = 100 cm |
| (c) 130 kVp, SSD = 50 cm | |

where SSD stands for source-to-skin distance and the field size for all beams is $10 \times 10 \text{ cm}^2$.

(ii) In diagnostic radiology the photon beam attenuation through photon absorption phenomena gives the ideal photon image, while the attenuation through scatter contributes no useful information and only degrades the final image quality. Discuss the origin of scatter, its physical characteristics and its relationship with beam parameters. Also define radiologic contrast and discuss the contrast reduction by scattered radiation.

(iii) Radiographic grid is utilized to remove scatter radiation from large x-ray fields. Discuss the grid in general and briefly define or explain:

- | | |
|----------------------|-------------------------------|
| (a) grid ratio | (f) parallel grid |
| (b) linear grid | (g) grid cassette |
| (c) focused grid | (h) Bucky factor |
| (d) convergent line | (i) moving grid |
| (e) convergent point | (k) primary grid transmission |

(iv) In addition to grids, various other techniques have been proposed to decrease the deleterious effect of scatter on the final radiographic image. Discuss at least two of these techniques.



B.4 PHYSICS OF DIAGNOSTIC RADIOLOGY

- (i) The quality of an x-ray beam is best defined by a photon spectrum, i.e., photon fluence per energy interval $d\phi/dE$ vs photon energy E . Sketch a typical photon spectrum obtained from a 100 kV constant potential x-ray tube with a tungsten target and briefly discuss a technique for the measurement of the energy spectrum.
- (ii) Briefly discuss the effects of peak tube potential, high voltage waveform and beam filtration on the x-ray spectrum produced by a diagnostic x-ray system.
- (iii) The quality of an x-ray beam is also given by the half-value-layer HVL. Define HVL and explain the procedure for its measurement. Sketch typical attenuation curves obtained with aluminum, and: (a) a 100 keV monoenergetic x-ray beam, and (b) a 100 kVp heterogeneous x-ray beam. Discuss beam hardening, define the homogeneity coefficient and sketch on the same diagram two photon spectra, one for a 150 kVp (tungsten target) x-ray beam before it passes through a lead filter and the other for the same beam transmitted through the lead filter. Briefly discuss the difference between narrow and broad beam attenuation.
- (iv) Explain how you would obtain the HVL from the photon spectrum sketched in (i).
- (v) Briefly define or explain:
- | | |
|-------------------------|--------------------------------------|
| (a) inherent filtration | (f) Thoraeous filter |
| (b) added filtration | (g) wedge filter |
| (c) aluminum equivalent | (h) beam alignment |
| (d) compound filter | (i) x-ray collimator |
| (e) K-edge filter | (k) effective energy of x-ray beam . |
- (vi) Image formation in diagnostic radiology depends upon the differential attenuation between tissues. Discuss in detail this differential attenuation and sketch the linear attenuation coefficient as a function of photon energy for tissue, bone and air in the diagnostic energy range. Also sketch and discuss the penetration by photons of an arbitrary thickness of air and bone relative to the penetration of soft tissue in the photon energy range between 10 keV and 100 keV.



Wayne State University
School of Medicine

B.5 PHYSICS OF DIAGNOSTIC RADIOLOGY

- (i) Two basic factors determine the clarity of the radiographic image: radiographic contrast and image quality. The radiographic contrast depends on three factors: subject contrast, film contrast and scatter radiation plus fog.
 - (a) define subject contrast and discuss in detail its dependence on the physical properties of the object and the radiation source;
 - (b) define film contrast and discuss in detail its dependence on the physical properties of the film, film processing, and radiation source;
 - (c) discuss scatter radiation and fog and explain why they decrease the radiographic contrast.
- (ii) The radiographic image quality is affected by quantum mottle, unsharpness and resolution.
 - (a) Discuss in detail quantum mottle (noise) and explain how it is affected by the speed of a film-screen combination. Discuss the effect of film graininess on radiographic mottle;
 - (b) Define unsharpness, sometimes referred to as blur. Show that it consists of various components, such as: geometry, motion, absorption screen and parallax unsharpness. Briefly discuss these;
 - (c) Define and discuss resolution and explain how it is measured. Also define the contrast transfer function CTF and show its relationship to resolution.
- (iii) Illustrate by diagrams the change in geometric unsharpness with:
 - (a) size of the apparent focal spot of the x-ray tube,
 - (b) distance between the object and the detector,
 - (c) distance between the x-ray tube and the object.
- (iv) The imaging properties of an x-ray tube depend upon the focal spot. The size of the focal spot is studied using a pinhole camera or by taking a picture of a line-pair resolution test pattern. Discuss and illustrate by diagrams the two techniques for focal spot size measurement.
- (v) Discuss the variation of the focal spot size with x-ray tube current and x-ray tube potential.



Wayne State University
School of Medicine

B.6 PHYSICS OF DIAGNOSTIC RADIOLOGY

- (i) Discuss in detail the physical characteristics of x-ray film.
- (ii) Discuss in detail the formation of the latent image from the photon image with x-ray film.
- (iii) Briefly discuss the film development process and clearly state the parameters affecting it.
- (iv) Discuss in detail the photographic characteristics of x-ray film. Sketch a typical saturation curve for x-ray film and define or explain:
- | | |
|--------------------------------------|------------------------------|
| (a) photographic density | (f) speed or sensitivity |
| (b) film contrast | (g) reciprocity law |
| (c) radiographic vs subject contrast | (h) film fogging |
| (d) film gamma | (i) sharpness |
| (e) film latitude | (k) toe and shoulder regions |
- (v) Briefly discuss some of the factors of geometry and trigonometry which influence the quality of the radiographic image. Define or explain:
- | | |
|------------------------|----------------------------|
| (a) focal spot | (f) absorption unsharpness |
| (b) magnification | (g) geometric unsharpness |
| (c) penumbra | (h) screen unsharpness |
| (d) object distortion | (i) edge transmission |
| (e) motion unsharpness | (k) focus-film distance |
- (vi) Derive the inverse square law relationship.



Wayne State University
School of Medicine

B.7 PHYSICS OF DIAGNOSTIC RADIOLOGY

- (i) The radiographic film is relatively insensitive to x-ray photons. Intensifying screens, which increase recording speed by an order of magnitude or more and which also increase the gamma of film, have been introduced to medical radiography to improve receptor sensitivity. Sketch typical H & D curves for film with no screens and film with screens and numerically indicate the improvements in gamma and speed.
- (ii) Discuss in detail the physical aspects of the intensifying process and define or explain:
- | | |
|---------------------------|-------------------------|
| (a) fluorescence | (f) phosphor |
| (b) phosphorescence | (g) K-absorption edge |
| (c) activator | (h) rare earth elements |
| (d) impurity | (i) valence band |
| (e) conversion efficiency | (k) photocathode |
- (iii) Briefly define or explain the following parameters in relationship to intensifying screens:
- | | |
|-----------------------------------|--------------------------------------|
| (a) quantum detection efficiency | (f) effect of temperature on screens |
| (b) conversion efficiency | (g) screen blur and its sources |
| (c) receptor sensitivity | (h) effect of screens on phototimers |
| (d) speed of intensifying screens | (i) screen asymmetry |
| (e) halation | (k) quantum mottle |
- (iv) Intensifying screens are used in film radiography, fluoroscopy and photofluorography. Discuss the components of screens, give at least five materials used as phosphors and for each phosphor discuss the important properties, such as:
- | | |
|---------------------------|-------------------------------------|
| (a) conversion efficiency | (d) absorption of x-ray photons |
| (b) emission spectrum | (e) effect of screens on resolution |
| (c) unsharpness of screen | (f) intensification factor |
- (v) Briefly discuss and compare the relative merits used in selecting a film-screen system for general radiography, mammography and extremity radiography in a modern radiology department.



Wayne State University
School of Medicine

B.8 PHYSICS OF DIAGNOSTIC RADIOLOGY

- (i) Intensified radiography or fluoroscopy has three basic components: the image intensifier tube, an optical system for coupling the image intensifier to the viewing system, TV camera or film, and the film or TV monitor. Sketch the arrangement of an image intensifier with its accessories to carry out fluoroscopy.
- (ii) Sketch an image intensifier tube and clearly label and discuss its components. Define the following parameters of an intensifier tube:
 - (a) brightness gain
 - (b) minification gain
- (iii) Discuss the physical principles involved in the production of the visible radiological image with an image intensifier. Also discuss the image quality obtained with image intensifiers (quantum mottle, contrast, resolution and image distortion).
- (iv) Sketch a diagram of a cineradiography system, clearly identify and briefly discuss its major components. Also discuss the synchronization of film movement and x-ray exposure.
- (v) The first prerequisite for optimum cinefluorography is a good x-ray photon image. Briefly discuss methods for optimizing the photon image and explain the effect the following factors have on the photon image:

(a) scatter	(d) quantum mottle
(b) motion unsharpness	(e) contrast
(c) geometric unsharpness	



B.9 PHYSICS OF DIAGNOSTIC RADIOLOGY

- (i) Sketch a block diagram of a fluoroscopy unit based on an image intensifier/closed circuit TV system and clearly label its main components.
- (ii) Briefly define or explain:
- | | |
|------------------------------------|--|
| (a) video signal | (f) bandwidth of video signal |
| (b) horizontal scan lines | (g) the gamma |
| (c) electron gun | (h) lag in TV camera |
| (d) scanning frame | (i) electrical enhancement of fluorescence |
| (e) interlaced horizontal scanning | (k) electroluminescence combined with photo-conductivity |
- (iii) Sketch the vidicon TV camera used in fluoroscopy, clearly label its components and explain its operation. Also briefly discuss the plumbicon and image orthicon cameras and state their advantages and disadvantages in comparison with commonly used vidicon cameras.
- (iv) Discuss the production of the video signal in the target of the vidicon camera.
- (v) Discuss the production of the visible image from the video signal in the TV monitor.

REFERENCE

The Physical Basis of Medical Imaging, by Coulam



Wayne State University
School of Medicine

B.10 PHYSICS OF DIAGNOSTIC RADIOLOGY

(i) Briefly define or explain:

- | | |
|----------------------------|----------------------------------|
| (a) spatial frequency | (f) contrast transfer function |
| (b) modulation | (g) Wiener spectrum |
| (c) Fourier transformation | (h) quantum noise |
| (d) amplitude spectrum | (j) linear imaging |
| (e) band width | (k) linearity of imaging systems |

(ii) Define the concept of linear systems and give their main characteristics. List at least three linear imaging systems and one example of a non-linear system.

(iii) Briefly discuss with sketches the resolution and its measurement when it is defined by:

- the smallest distance between two objects that can just be resolved in the image as being separate, and
- the largest number of lines per millimeter on a bar pattern which could just be distinguished in the image.

(iv) State for which of the following the image unsharpness cannot be specified by the line pair concept:

- | | |
|-------------------------|-----------------------|
| (a) x-ray focal spot | (d) image intensifier |
| (b) x-ray film | (e) TV camera |
| (c) intensifying screen | (f) object motion |

Explain why.

(v) Define, discuss and sketch the Point Spread Function (PSF) and the Line Spread Function (LSF).

- Discuss the technique for measurement of the two functions;
- Sketch experimental configurations for the LSF measurement of:
 - image intensifier, 2. screen/film combination, and 3. x-ray film alone. Sketch typical LSF's for 1., 2., and 3. above, and discuss what effect if any the x-ray focal spot will have on the measurement of LSF;
- Discuss the limitations of the two functions in resolution specification of complex x-ray systems.



Wayne State University
School of Medicine

B.11 PHYSICS OF DIAGNOSTIC RADIOLOGY

- (i) Describe the relationship between the point spread function PSF and image quality. Explain why this concept is impractical.
- (ii) Define and briefly discuss the Edge Response Function ERF. Sketch the experimental arrangement for its measurement.
- (iii) Define and discuss the modulation transfer function MTF, explain its relationship to and advantages over the LSF and the ERF. Also clearly state the limitations of the MTF concept.
- (iv) Briefly discuss the techniques used for measurement of the MTF and sketch examples of MTF's for the following:
 - (a) film alone
 - (b) focal spot
 - (c) intensifying screens, and
 - (d) image intensifier
- (v) Briefly discuss the MTF for moving objects.



Wayne State University
School of Medicine

B.13 PHYSICS OF DIAGNOSTIC RADIOLOGY

Mammography, a technique for the radiographic examination of the breast, poses special problems because of the low subject contrast given by the visualized tissues and the high resolution required.

- (i) Describe the characteristics of the following x-ray equipment used in mammography:
 - (a) x-ray target and filter
 - (b) focal spot
 - (c) anode voltage
 - (d) exposure time and output exposures
 - (e) target-to-image receptor distance
- (ii) Briefly discuss the characteristics of both screen-film and xeroradiography imaging systems and explain how the two systems are used in high resolution mammography. State the advantages and disadvantages of each system when used in mammography.
- (iii) Briefly discuss four other breast imaging techniques and explain their advantages and disadvantages.
- (iv) Explain briefly how you would periodically calibrate a unit used routinely for mammography, clearly state the machine parameters to be checked as well as the method and equipment to be used in the calibration.
- (v) Briefly discuss the risks involved in performing routine mammography using x rays.



Wayne State University
School of Medicine

B.15 PHYSICS OF DIAGNOSTIC RADIOLOGY

(i) Briefly define or explain:

- | | |
|------------------------------|---------------------------|
| (a) array processor | (f) convolution filtering |
| (b) pixel | (g) dual energy CT |
| (c) voxel | (h) cardiovascular CT |
| (d) CT wedge calibration | (j) quantitative CT |
| (e) filtered back projection | (k) Hounsfield number |

(ii) Sketch and label the major components of a modern CT scanner capable of acquiring data for a tomogram in less than 5 seconds.

(iii) Describe with sketches the fundamental principles of x-ray transmission tomography, including data acquisition and image reconstruction.

(iv) Compare the various types of x-ray detectors which have been used in CT.

(v) Discuss the beam hardening effect and define the Hounsfield scale of CT numbers. Also define the CT number level and window used to specify the grey-tone display of the image.

(vi) Give typical numerical values for the following parameters as they pertain to CT imaging:

- (a) x-ray tube kilovoltage
- (b) effective photon energy for the measured attenuation coefficients
- (c) the spatial resolution (at high contrast)
- (d) the image display matrix size
- (e) the image noise
- (f) the CT number values for: air, lung, feet, brain, water, trabecular bone, cortical bone
- (g) the patient dose per tomogram and per complete examination (e.g., 10 tomograms).

REFERENCE

The Physical Basis of Medical Imaging, by Coulam



B.14 PHYSICS OF DIAGNOSTIC RADIOLOGY

(i) Briefly define or explain the following parameters related to digital radiography:

- | | |
|---------------------|-------------------------|
| (a) CPU | (f) motion artifact |
| (b) array processor | (g) saturation artifact |
| (c) ADC | (h) video frame |
| (d) aliasing | (i) contrast media |
| (e) interlacing | (k) photoconductor |

(ii) Current digital radiographic (DR) systems can be divided into two categories: digital videofluoroscopy systems and scan projection radiographic (SPR) systems. Sketch and clearly label the primary components of:

- (a) a conventional film-based radiography system
- (b) a conventional intensified videofluoroscopy system
- (c) a digital videofluoroscopy system
- (d) an SPR system

(iii) What are the advantages and disadvantages of each system discussed in (ii).

(iv) Briefly discuss the procedures and equipment used in DR to digitize the analog voltage signals which are produced by the video camera. Also discuss the effects of various digitization processes on the horizontal and vertical resolutions of the final analog image. Give typical values for resolution capabilities of imaging techniques of (ii).

(v) The procedure most frequently performed using the digital fluoroscopy system is the digital subtraction angiography (DSA). Discuss the rationale for and procedures employed in subtraction techniques in general and clearly state the advantages of DSA over conventional angiography techniques.

(vi) Briefly discuss:

- (a) pencil beam
- (b) fan beam, and
- (c) area beam SPR systems.

State the advantages and disadvantages of each in comparison with digital videofluoroscopy systems.

REFERENCE

Recent Developments in Digital Imaging, edited by Kunio Doi, Lawrence Lanzl, and Pei-Jan Paul Lin.



B.12 PHYSICS OF DIAGNOSTIC RADIOLOGY

- (i) Briefly discuss the general aspects of a quality control program in a typical radiology department.
- (ii) Explain the procedure and equipment used for the quality control tests of the following parameters of radiographic equipment:
- | | |
|---|-------------------------|
| (a) kVp : Ardram-Crooks cassette,
Wisconsin cassette and voltage divider | (f) radiation output |
| (b) mA stations | (g) half-value layer |
| (c) exposure timer | (h) film-screen contact |
| (d) focal spot | (i) phototimer |
| (e) collimator/beam alignment | (k) grid alignment |
- (iii) Explain the procedure and equipment used for the following routine quality control tests on fluoroscopic equipment:
- | | |
|----------------------|-------------------------------|
| (a) kVp | (e) collimator/beam alignment |
| (b) focal spot | (f) high contrast resolution |
| (c) output | (g) low contrast resolution |
| (d) half-value layer | |
- (iv) Briefly discuss routine quality control procedures on film processor units:
- | | |
|------------------|------------------|
| (a) sensitometry | (b) densitometry |
|------------------|------------------|
- (v) Briefly describe a quality control program for image intensifiers, clearly stating what parameters you would measure and how you would perform the measurements.

B.16 PHYSICS OF DIAGNOSTIC RADIOLOGY

- (i) Briefly define or explain:
- | | |
|------------------------|--------------------------------|
| (a) foil electret | (f) photoconductor |
| (b) corona charging | (g) edge enhancement |
| (c) polymer | (h) electrostatic latent image |
| (d) ion pair | (j) triboelectrification |
| (e) electron-hole pair | (k) electrographic toner |
- (ii) Electrostatic imaging is sometimes considered as a possible alternative to radiology based on film. Compare the latent images in the two techniques and discuss in general the advantages and disadvantages of electrostatic imaging compared to film.
- (iii) Electrostatic imaging has been performed either in the charge cancellation mode (xero-radiography) or in the charge accumulation mode (ionography or electron radiography). Discuss and show schematically the two modes, and point out the advantages or disadvantages of each of them.
- (iv) Gases, liquids and solids have been used as radiation sensitive media in electrostatic imaging. Briefly discuss the various materials employed and explain the reasons for their use.
- (v) Briefly discuss and sketch the development process of electrostatic latent images with electro-graphic toner techniques.
- (vi) Electrostatic latent image subtraction can be performed by applying the charge accumulation mode at one polarity to get the primary latent image, and the charge cancellation mode at the opposite polarity to get the subtracted image. Briefly discuss the technique.



Wayne State University
School of Medicine

B.17 PHYSICS OF DIAGNOSTIC RADIOLOGY

- (i) Briefly describe the following radiological procedures:
- | | |
|-----------------------------|---------------------------|
| (a) angiography | (f) myelography |
| (b) aortography | (g) mammography |
| (c) arteriography | (h) stereorentgenography |
| (d) cholangiography | (i) ventriculography |
| (e) intravenous pyelography | (k) pneumoencephalography |
- (ii) Contrast media are used in radiology to improve the visualization of some organs in the body. The three most common types of contrast agents are: air, compounds containing iodine, and compounds containing barium. Discuss the important radiological properties of these agents, list at least five examples of their use in radiology and plot the mass attenuation coefficients for air, iodine and barium in the photon energy range between 10 keV and 100 keV.
- (iii) The purpose of subtraction techniques in radiology is to make diagnostically important information easier to see. Briefly discuss the general principles of subtraction radiology.
- (iv) Briefly define and discuss the following subtraction techniques:
- (a) photographic
 - (b) digital subtraction angiography (DSA)
 - (c) K-edge fluoroscopy and radiography
 - (d) dual energy subtraction



Wayne State University
School of Medicine

B.18 PHYSICS OF DIAGNOSTIC RADIOLOGY

- (i) Describe the theory behind "Dichromatic Absorptiometry of Vertebral Bone Mineral Content". Assume that the energy source has two monochromatic photons at 44 keV and 100 keV (i.e., Gd-153).
Be sure to include in the discussion the importance of:
- (a) selection of photon energy and effect on mass absorption coefficient for bone and soft tissue
 - (b) correction for spill-over and background
 - (c) derivation of equation for bone mineral content
- (ii) Describe one other technique commonly used to evaluate bone mineral content. Compare it with the above technique, in terms of diagnostic accuracy, availability, radiation exposure, etc.

REFERENCE

Noninvasive Bone Measurements: Methodological Problems (J. Dequeker and C. C. Johnston, Jr., eds.) IRL, Oxford, England (1982). *Noninvasive Measurements of Bone Mass & Their Clinical Applications*, edited by Stanton Cohn (CRC, Boca Raton, FL, 1981)



Wayne State University
School of Medicine

C.1 PHYSICS OF NUCLEAR MEDICINE

(i) Briefly define or explain:

- | | |
|---------------------|------------------------------|
| (a) dynode | (f) valence band |
| (b) photocathode | (g) forbidden zone |
| (c) fluorescence | (h) energy gap |
| (d) phosphorescence | (j) surface barrier detector |
| (e) luminescence | (k) n-type semiconductor |

(ii) Describe in detail the principle of operation of a scintillation counter. Draw a diagram of a typical counter and clearly label its components. Also describe in detail a photomultiplier tube and describe its operation.

(iii) Discuss photon energy spectrometry based on scintillation detectors. Sketch a typical pulse height spectrum and define the following features:

- | | |
|--------------------------------------|-------------------------------|
| (a) photopeak | (e) coincidence-sum peaks |
| (b) Compton valley, edge and plateau | (f) backscatter peak |
| (c) x-ray escape peaks | (g) annihilation peak |
| (d) annihilation escape peak | (h) characteristic x-ray peak |

(iv) Discuss the photopeak energy resolution in scintillation spectrometry and give typical values for at least three different scintillation materials. Discuss the reasons for a relatively poor resolution of scintillation detectors. Sketch a pulse height spectrum obtained with a NaI(Tl) crystal for a Cs-137 gamma source (photon energy 662 keV). Indicate which features of (iii) you will observe on the spectrum.



Wayne State University
School of Medicine

C.2 PHYSICS OF NUCLEAR MEDICINE

(I) Briefly define or explain:

- | | |
|---|----------------------|
| (a) radiation quality | (f) ALARA principle |
| (b) somatic effects | (g) Gray |
| (c) stochastic effects | (h) Sievert |
| (d) relative biological effectiveness (RBE) | (j) NRC |
| (e) maximum permissible dose | (k) LD ₅₀ |

(ii) What is the dose rate at the point where a beam of energetic beta particles is incident upon the body if, over an area of 1 cm², 100 beta particles are crossing per second? Give your answer in SI units and state any assumptions you find necessary to make.

(iii) A patient receives 5.5 GBq of I-131 for treatment of thyroid metastases.

- What precautions must be taken to ensure proper protection of other persons?
- Should the patient's urine be collected? If so, for how long and how should it be disposed of? What are the arguments against such collection?

(iv) The chairman of the local university physics department is referred to the nuclear medicine department for a bone scan. During the examination he asks a number of questions pertinent to radiation safety. Give your responses to the following questions:

- To which official agencies is the department responsible for:
 - procurement, 2. storage, 3. usage (in vivo), and 4. disposal of radiation material?
- What are the detrimental effects of radiation at the levels in use in a nuclear medicine department?
- Are there any realistic circumstances in diagnostic nuclear medicine when a potentially dangerous dose of a radiopharmaceutical agent may be administered to a patient?
- What are the sources and magnitudes of natural background radiation? How may these be modified?
- What instruments would you want to have available for purposes of monitoring radiation levels, and why?



Wayne State University
School of Medicine

c.3 PHYSICS OF NUCLEAR MEDICINE

(i) Briefly define or explain:

- | | |
|-----------------------|----------------------------------|
| (a) beta particle | (f) linear energy transfer (LET) |
| (b) alpha particle | (g) half-value layer (HVL) |
| (c) ionization | (h) positron decay |
| (d) K-absorption edge | (j) electron capture |
| (e) ion pair | |

- (ii) Describe the processes by which the energy from a beta particle emitted from an I-131 atom within the thyroid may be absorbed by the surrounding tissue. What biological damage may result from these processes?
- (iii) Using the principle of conservation of energy and momentum, show that a photoelectric process cannot take place with a free electron.
- (iv) For Tc-99m and I-131 sketch graphs showing the energies of Compton-scattered photons versus angle.
- (v) Discuss the implications of these graphs for imaging with a scintillation camera having a NaI(Tl) detector which is 1/2" thick. Refer specifically to detector photopeak efficiency and the (in) ability of pulse height analysis to discriminate against photons scattered in the patient.



Wayne State University
School of Medicine

C.4 PHYSICS OF NUCLEAR MEDICINE

- (i) Describe the operation of three types of personnel radiation monitors that depend on different methods to detect and integrate the radiation exposure dose. Indicate the advantages and disadvantages of each type of detector.
- (ii) A surface is surveyed with a G-M counter for contamination and a small spot of contamination is found which gives a reading of 15,000 counts/min.
The normal background reading is 45 counts/min. The counting rate becomes negligible when a 5 mm plastic absorber is placed over the area. The counting rate for a bismuth-210 beta reference source counted in a similar manner is 9400 counts/min but is known to emit 32,600 beta particles/min. What is the rate of emission of beta particles from the contaminated surface?
- (iii) What factors modify the count rate detected by the G-M detector used in (ii) above ?
- (iv) A patient, whose thyroid weighs approximately 20 grams, is given an oral dose of 3.5 MBq of I-131. Using the "classical" method of calculation (not MIRD), what is the initial beta dose rate in Grays to the thyroid if the uptake is 30% ? See attached table for details of I-131 beta decay.
- (v) How much I-125 and P-32 may be discharged by a hospital if the water bill shows that the institution uses $1.2 \cdot 10^7$ cubic feet/annum ? Allowable average concentrations of I-125 and P-32 are 4×10^{-5} $\mu\text{Ci/ml}$ and 5×10^{-4} $\mu\text{Ci/ml}$, respectively.
- (vi) What factors will modify the amounts calculated in (v) above ?
- (vii) A nuclear medicine department releases spent Xe-133 through a vent on the roof of the building. The flow rate of the air through the hood which has an opening of 1 m^2 is 7.1 linear m/min. What is the maximum permissible weekly discharge rate ? (Air concentrations of Xe-133, averaged over 1 year, shall not exceed 3×10^{-7} $\mu\text{Ci/ml}$).



Wayne State University
School of Medicine

C.5 PHYSICS OF NUCLEAR MEDICINE

- (i) Sketch a Poisson distribution which would correspond to the distribution of counts from a radioactive source, where determinations have been made for a fixed period of time. Assume that the true average is 1000 counts per 10 seconds. Indicate on the graph the range in counts in which 66%, 95%, and 99% of the observations should fall.
- (ii) Give an analytical expression for the Poisson distribution and derive an expression for the variance of the mean.
- (iii) If the "true" background radiation level is 1000 counts per minute, which of the following techniques would best estimate this background activity and why? Justify the error propagation assumptions that you make
- counting background 100 times for 1 minute and then taking the mean of the readings
 - counting the background in one 100 minute sample.
- (iv) Nuclear medicine imaging procedures are often terminated using "count density" criteria. Making assumptions regarding system spatial resolution of a gamma camera, suggest what count density is required to demonstrate that a 10 per cent change in counts per centimeter squared is significant at a 95 per cent confidence level?
- (v) Let pixels of two digitized gamma scintillation camera images be represented by $X(i,j)$ and $Y(i,j)$ with assumed errors of $\Delta X(i,j)$ and $\Delta Y(i,j)$ respectively. What is the error of a picture element formed by:

$$X(i,j) \cdot Y(i,j) \text{ , and by: } X(i,j) + Y(i,j) ?$$

What is the error of a picture element after an image has been spatially smoothed?
Assume the smooth has weighting of 4 (central pixel), 2 (four closest neighbours) and 1 (next closest neighbours), i.e. :

$$\begin{array}{ccc} 1 & 2 & 1 \\ \hline 2 & 4 & 2 \\ \hline 1 & 2 & 1 \\ \hline \end{array}$$



Wayne State University
School of Medicine

C.6 PHYSICS OF NUCLEAR MEDICINE

- (I) What are the relevant design parameters for collimators used in clinical radionuclide imaging? How do these characteristics affect the performance of the collimator?
- (ii) What collimators would you select for each of the following procedures? Explain the reasons for your choice.
 - (a) first-pass angiography
 - (b) images of the knee using gallium-67 citrate ("spot views")
 - (c) a lung scan to detect metastases in a patient with local recurrence of thyroid cancer treated with radiiodine three days earlier.
- (iii) Outline the gamma camera quality control protocol that should be established when setting up a nuclear medicine department. Indicate the frequency of the procedures to be performed and briefly describe the techniques used.
- (iv) Draw five examples of abnormal test patterns obtained using a bar phantom, making reference to the type of equipment malfunction involved.



Wayne State University
School of Medicine

D.11 DOSIMETRY

(i) Briefly define or explain:

- (a) guard electrodes
- (b) air-wall material
- (c) collection efficiency
- (d) Roentgen
- (e) build-up cap

- (f) W for air
- (g) extrapolation chamber
- (h) chamber calibration factor
- (j) ion pair
- (k) initial and general recombination

(ii) Draw schematically and briefly discuss the standard free air ion chamber and clearly state its limitations.

(iii) Draw schematically a parallel-plate (pancake) and a thimble ion chamber, label their main components and show a simple electronic circuit associated with them.

(iv) Draw a saturation curve for a typical parallel-plate ion chamber irradiated with a continuous photon beam and briefly discuss the behavior of the saturation curve as a function of radiation intensity, electrode separation and photon energy.

(v) Briefly discuss the use of ferrous sulphate dosimetry and calorimetry as the only alternatives to ion chambers in absolute dosimetry.



Wayne State University
School of Medicine

D.12 DOSIMETRY

- (i) **Thermoluminescent Dosimetry (TLD) is the most prominent of the numerous relative dosimetry techniques. Discuss the basic physics behind the TL process, show schematically a typical apparatus for TLD measurements and clearly label the components.**
- (ii) **Briefly define or explain :**
- | | |
|--------------------------|--|
| (a) TLD phosphor | (f) infrared emission of the planchet |
| (b) TLD-100 | (g) activation energy |
| (c) glow curve | (h) supralinearity |
| (d) photomultiplier tube | (j) pre- and postirradiation annealing |
| (e) optical filter | (k) recombination center |
- (iii) **Name at least five substances which are currently used as TL dosimeters, and give their main characteristics such as: effective atomic number, relative sensitivity, spectral response, temperature of dosimetric peaks, etc.**
- (iv) **Name at least five relative dosimetry techniques other than TLD and briefly discuss their main characteristics.**

American Board of Radiology
Radiological Physics Exam - Part I 1985

After taking this exam the following topics were noted as being stressed in multiple questions. This topic list was prepared in the event that I would have to retake this exam (luckily I did not)!

INTERACTIONS - PHOTONS & PARTICULATES

Mass Attenuation Coefficients
Photon Interactions (PE, COMP, PP)
Know equations!!! ie. E_{ce} , E_{photon} , E_{pe} , etc.
Know what each interaction depends on ie. Z, etc.
Shielding - Barriers

ELECTRICITY

Ohm's Law
Circuits - Relationships & Design

BASIC PHYSICS

Force, Pressure, Work, Sound, etc. - Know Equations

RADIATION BIOLOGY

Latent Periods vs Radiation Induced Disease
Doses---> Effects ie. Ranges for certain effects
Survival Curves
Human Data vs Theory
Quasi-Threshold

DIAGNOSTIC RADIOLOGY

Tubes - Know interrelationships ie. Anode Angle effects
what?
Procedure Setups ie. mAs, kVp etc.
Barriers

INSTRUMENTATION

Instrument of choice in particular situations ie. scatter
measurements

RADIOACTIVE DECAY

Types - nuclear events leading to each decay process
MeV - amu mass conversion calculation

COUNTING STATISTICS

Std. Deviation of counts, count rates
Optimum division of counting times

ULTRASOUND

Scan types vs application

CT

Enhancement results ie. Which pathophysiological conditions
are best represented by contrast
Review Anatomy - Scans

ABR Part I - 1985 cont'd.

RADIATION SAFETY

Calculation of doses and permissible times
MPD for organs, different groups of population
Sign posting requirements

ANATOMY & PHYSIOLOGY

Know malignant vs benign disease types
Bone anatomy
Hormone to organ matching
Point of origin
Organ most affected

IMAGE INTERPRETATION

CT images: Abdomen & Pelvis
MR images: Head & Body

American Board of Radiology
Examination for Certification in Physics (Therapy)
October, 1985

Part I. Part I was divided into the three types of questions which are discussed in the ABR pamphlet. There were approximately 175 questions of each type which means that there were probably about 1000 total answers. Approximately 10 to 15% (more than I would have expected) were on anatomy, physiology and endocrinology. There were 4 CT slices of the chest and abdomen which required identification of anatomical structures. These were not particularly difficult since identification was required only for major structures. The questions on radiation biology were concerned with the basic parameters such as D_0 , D_q , n and survival curves. There were also questions on RBE, OER and some knowledge of BIER doses was needed.

There were very, very few questions on ultrasound, CT or MRI but there were many, many questions on statistics, and nuclear medicine counting, (standard deviation, distributions, etc.). A calculator (non-programable of course) with some stat functions would be very helpful and save a lot of time. The diagnostic x-ray questions were mostly in the area of tube characteristics (falling load, focal spots, etc.).

Nuclear physics questions were in the area of radiation/matter interaction and required knowledge of the P.E., Compton and pair production parameters. There were not many computer questions and most of those were about binary/octal numbers.

Health physics was covered with questions on radiation detection instrumentation. Knowledge of different type of detectors and their application was needed. There were H.P. questions which required some dose calculations and took some time.

An overall review of glossary terms would be helpful. There were many questions on the units and relationship between force, energy, power, momentum, etc., and on the analytical description of physical laws such as the uncertainty principle, phase/group relationship.

Part II. There were six essay questions (some with multiple parts) with four to be answered. The therapy questions were as follows:

1. Four field pelvis dosimetry. Given TAR and OCR tables and various dimensions and a 200 rad target dose, determine doses at various locations. The technique was SSD. This required a great deal of calculation and took about 1/3 of the allotted time.

2. Given 8 Mev e^- impinging on a 2 cm unit density tissue overlying 0.5 density lung, determine how much lung is irradiated. How could you reduce the volume of lung irradiated?

Therapy Essay (cont)

3. Describe the main features of the new dosimetry protocol (TG21). How does it differ from the old method?
4. Describe what produces skin sparing for high energy photons and what parameters affect the depth of maximum dose.
5. Given the dimensions of a tumor volume, 0.5 mCi 125 Iodine seeds and the Anderson nomogram, plan the implant (spacing, location, etc).
6. Low energy e- impinge on a cheek. How would you protect the bucal mucosa and what are the doses received.

Radiation Protection:

1. Given 140 (7 x 20) mRe of Cesium in a 1" Pb pig (HVL = 0.65 cm) improperly stored in a housekeeping closet with a typist in the next room 0.5 m away for 5 days, 7 hrs/day and 50% transmission through the wall, determine the dose received, the NRC regs which were violated. What must be included in the incident report and what topics should be discussed during counseling.

DIAGNOSTIC

=====

- I. A physician is complaining of poor fluoroscopic images...
 - a. discuss the components which affect image quality
 - b. how would you test these components?
 - c. compare patient and II entrance doses

- II. Computerized tomography...
 - a. discuss factors which affect large area detection, resolution, and dose efficiency
 - b. an artefact caused by petrous bone in the skull occurs on a properly calibrated, functioning CT. What causes this artefact? How would you eliminate it?
 - c. For a 320X320 matrix, how many projections are needed to suppress aliasing? Give reasoning.

- III. Digital Subtraction Angiography
 - a. what additional equipment would you need to add/replace in a conventional angiography room to do DSA?
 - b. describe the following modes: mask mode, road mapping, dual energy, and time interval
 - c. describe a method of doing edge-enhancement using a computer

- IV. Magnetic Resonance Imaging
 - a. describe the process of obtaining a spectrum of a small liquid or tissue sample. What would the spectrum look like for pure water?
 - b. describe spin-echo and inversion recovery pulse sequences
 - c. describe how you would obtain 2-D spatial information during a spin-echo sequence

DIAGNOSTIC PROTECTION

=====

- I. Shielding design using the short-cut (table) method.

- II. Comparison between angiography and cine exposure. What are the factors which contribute to the dose?

NUCLEAR MEDICINE PHYSICS

=====

I. Blood volume calculation. Given cpm data for standard, whole blood, plasma, and water:

- a. calculate plasma volume, blood volume, red cell volume, and hematocrit
- b. what precautions should be followed?

II. Positron Emission Tomography

- a. describe the principle of PET
- b. what are the advantages vs. disadvantages of PET compared with traditional nuclear imaging techniques?
- c. name 3 nuclei used in PET imaging and give the activation equations to produce them

III. Fourier Transforms

- a. describe the FT of 128 X 128 nuclear medicine images
- b. describe how to use a sinc function to enhance a particular frequency
- c. describe the correlation of two 128 X 128 matrices

IV. Dose calibrator

- a. describe the components of an ionization dose calibrator. use diagrams
- b. for the range of energies and gamma ray constants used in nuclear medicine, what component is adjusted to compensate for this?
- c. what QA program should be implemented for the dose calibrator and how do you use Co-57 to do energy dependence testing?

NUCLEAR MEDICINE PROTECTION

=====

I. Absorbed Fraction Method

- a. explain the theory of calculating doses by this method. use equations and explain all variables and constants
- b. what is the cumulative activity for the following conditions:

instantaneous uptake, only T(b) considered
instantaneous uptake, only T(p) considered
instantaneous uptake, only T(e) considered
uptake not instantaneous

- c. what is meant by "dose reciprocity"?

II. A nuclear medicine department performs 3 lung scans per day using Xe-133. After the first study, the trap malfunctions. Given the room volume and exchange rate between the room and the rest of the hospital, (airloss per hour = 30%):

- a. how long before room concentration falls below the MPC value?
- b. how long for hospital as a whole to fall below MPC?
- c. assume the trap to be 95% efficient - given the gamma ray exposure rate for Xe-133 at 1 cm, what is the exposure rate at 2 meters after 48 hours?

1. A 6 MV photon beam is used to treat a patient 20 cm thick at 100 SAD. The machine has an output of 220 rad/min at 100 cm at depth of d_{max} . Calculate dose rates at the following points
- A at depth 10 cm for unblocked field
 - B at depth 5 cm for blocked field
 - C at depth 10 cm for blocked field

given off axis ratio table
 TMR table for fields 5X5, 10X10, and 15X15 at different depths
 TMR for 0X0 field is not given
 the following diagram

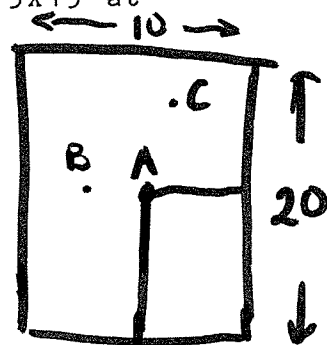

- 2a. Given a figure similar to that drawn below, discuss the change in dose at the points A - F.

- b. Discuss how you correct for inhomogeneities using the following methods: 1. TAR
 2. Batho power 3. don't remember.

- c. What is a CT number?
 How do you use this number in therapy when the CT scan has been obtained for diagnostic purposes?

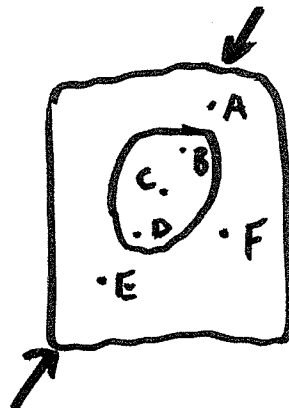

3. Total body Irradiation to treat mycosis fungoides

- a. What modality do you use for your beam? (photons? electrons? neutrons?)
- b. Describe the characteristics of the beam and the energy used.
- c. How do you calibrate and obtain the percent depth dose table, and etc.
- d. How do you treat between fingers?

Protection Question

Given a diagram of a hospital floor, a new room needs to be added and used for Cs-137 implant patients.

- a. Prepare an instruction sheet for nurses.
- b. What should you advise visitors?
- c. Calculate the thickness of a wall between two rooms and what material do you use for shielding?
Given: 250 mCi Cs-137
HVL of lead
HVL of concrete
- d. Is it necessary to shield the door, (door was about 12 feet from edge of patient's bed)?

PART ONE - MULTIPLE CHOICE QUESTIONS

Four hours duration: 1 PM to 5 PM

Examination consisted of three major sections.

Section A: Questions 1 through 70 (70 questions)

Each followed by five answers.

One answer is correct or best choice

Section B: Questions 71 - 136 (66 questions)

Each question is followed by (in most cases) 4 or (in some cases) 5 statements.

Each of the given statements must be labeled as True or False in the context of the question.

Section C: Questions 137 - 256 (120 questions)

This section uses matchups.

Four of five items are given followed by an equal number of questions.

Match the question with the best possible answer.

PART TWO - SPECIALIZED EXAMINATIONS

Three types of specialized examinations

Two hours for each examination. Given one after the other.

1. Therapeutic Radiological Physics: Four questions in therapeutic physics, out of which three must be answered.

Two questions in protection, one must be answered.

2. Diagnostic Radiological Physics: Four questions in diagnostic physics, three of which must be answered. Two

questions in protection, one must be answered.

3. Nuclear Medical Physics: Four questions in nuclear medicine physics, three of which must be answered.

Two questions in protection, one must be answered.

THE AMERICAN BOARD OF RADIOLOGY
1978 RADIOLOGICAL PHYSICS EXAMINATION: PART I

PU

2-35

Category L

Item Type B

Pictorial Material

¹⁴⁵
137. Match the following terms A-E with the definitions 1-4:

1978 Type A

- | | |
|---|---------------------|
| 1. Irregularity of muscular action | A. Atrophy |
| 2. A dilated artery or vein sac | B. Atelectasis |
| 3. Collapse of a lung | C. Ataxia |
| 4. Arterial lesions containing cholesterol deposits | D. Artherosclerosis |
| | E. Aneurysm |

149. For each numbered term 1-4, match the most closely associated anatomic region A-E.

1978 Type B

- | | |
|-------------------|-----------|
| 1. Hydronephrosis | A. Brain |
| 2. Osteoporosis | B. Bone |
| 3. Hydrocephalous | C. Kidney |
| 4. Arthritis | D. Joints |
| | E. Liver |

R=73
R=38

PART II DIAGNOSTIC RADIOLOGICAL PHYSICS (PROTECTION)

Part A

Determine the wall, floor and ceiling shielding protection for a typical body CT unit installed in the center of a 16 x 16 ft² room. Justify any assumptions you make. Attached are a table from NCRP Report #49 and exposure data for a typical CT unit which you may wish to use. State your results in practical terms suitable to the understanding of an architect, structural engineer or contractor.

Part B:

Discuss the radiation safety measures you would take in the design, installation, and evaluation of the CT scanner facility to make it as cost effective as possible.

TABLE 5—Minimum shielding requirements for radiographic installations

WUT ^a in mA min			Distance in meters from source to occupied area										
100 kV ^b	125 kV ^b	150 kV ^b	1.5	2.1	3.0	4.2	6.1	8.4	12.2	12.2	12.2	12.2	12.2
1,000	400	200											
500	200	100											
250	100	50											
125	50	25											
62.5	25	12.5											
Type of Area	Material	Primary protective barrier thickness ^c											
Controlled	Lead, mm ^c	1.95	1.65	1.4	1.15	0.9	0.65	0.45	0.3	0.2	0.1	0.1	0.1
Noncontrolled	Lead, mm ^c	2.9	2.6	2.3	2.05	1.75	1.5	1.2	0.95	0.75	0.55	0.35	0.35
Controlled	Concrete, cm ^d	18	15.5	13.5	11.5	9.5	7	5.5	4	2.5	1.5	0.5	0.5
Noncontrolled	Concrete, cm ^d	25	23	20.5	18.5	16.5	14	12	10	8			
		Secondary protective barrier thickness ^e											
Controlled	Lead, mm ^c	0.55	0.45	0.35	0.3	0	0	0	0	0	0	0	0
Noncontrolled	Lead, mm ^c	1.3	1.05	0.75	0.55	0.45	0.35	0.3	0.05	0	0	0	0
Controlled	Concrete, cm ^d	5	3.5	2.5	2	0	0	0	0	0	0	0	0
Noncontrolled	Concrete, cm ^d	11.5	9.5	7.5	5.5	4	3	2	0.5	0	0	0	0

^a W—weekly workload in mA min, U—use factor, T—occupancy factor.

^b Peak pulsating x-ray tube potential.

^c See Table 26 for conversion of thickness in millimeters to inches or to surface density.

^d Thickness based on concrete density of 2.35 g cm⁻³ (147 lb ft⁻³).

^e Barrier thickness based on 150 kV.

TYPICAL SCANNING TECHNICS

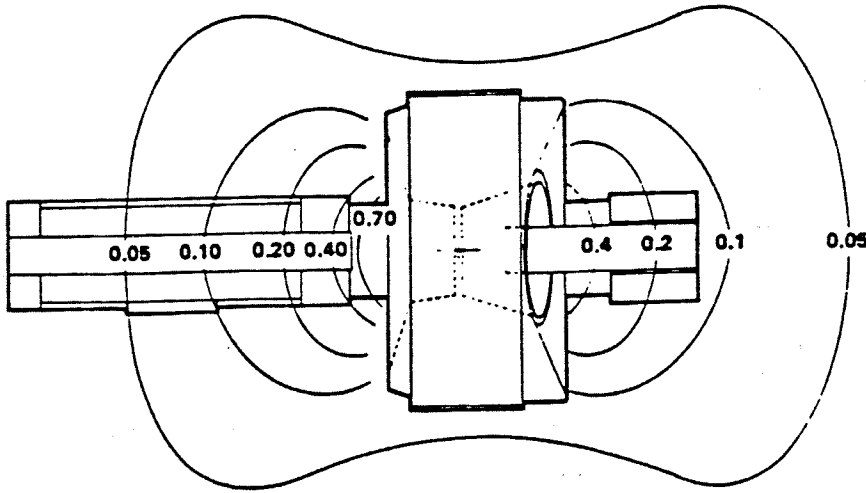

CT/T Survey Parameters

Phantom	42 cm Alcohol	kVp	120
Views	288	mA	200
Scan Time	4.8 sec.	Pulse	
Filter	Body	Width	2.2 ms

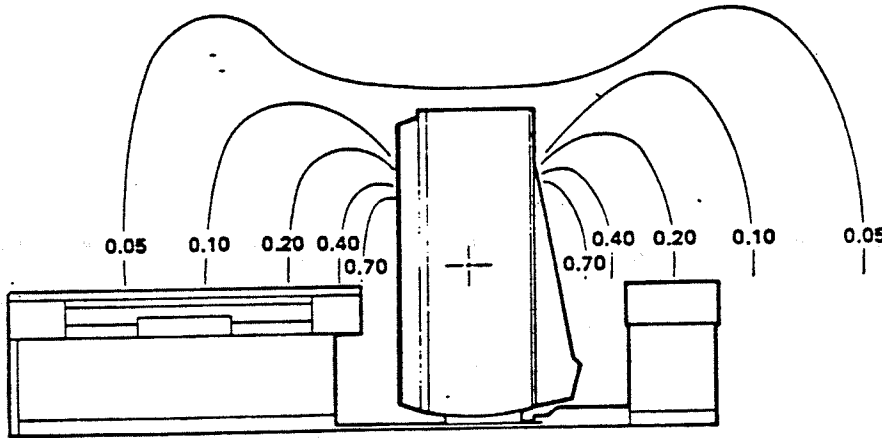

CT/T Survey Parameters

Phantom	42 cm Alcohol	kVp	120
Views	288	mA	200
Scan Time	4.8 sec.	Pulse	
Filter	Body	Width	2.2 ms

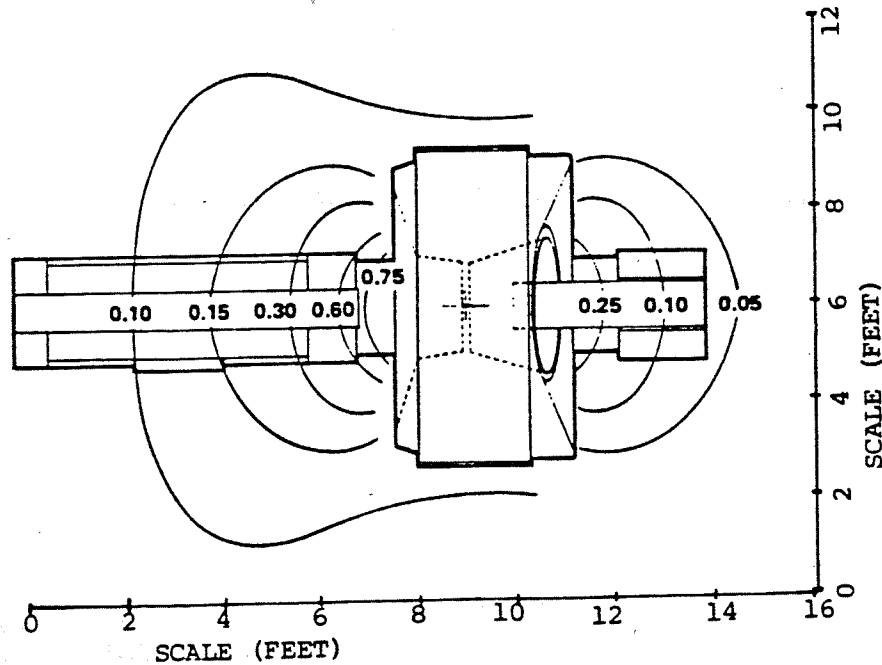

CT/T Survey Parameters

Phantom	Tommie	kVp	120
Views	576	mA	600
Scan Time	9.8 sec.	Pulse	
Filter	Head	Width	3.3 ms

1977
PART II
DIAGNOSTIC RADIOLOGICAL PHYSICS

D-3.
4 points **Part A:**

Discuss the contributions to noise in a radiographic image.

3 points **Part B:**

Is noise more significant in a cerebral angiogram or in a cholecystogram, and why?

3 points **Part C:**

Compare the properties of rare earth screens and CaWO₄ screens. For the same MTF, compare image noise for the rare earth and CaWO₄ screens.

1978

PART II
DIAGNOSTIC

its

Problem 2

An unfocused 19 mm diameter, 1.6 MHz pulse-echo ultrasound transducer is found to be 21 dB less sensitive to a small rod target in water at 11 cm range than an unfocused, 2.2 MHz transducer of the same diameter.

- a) Is the rod target in the near field (Fresnel zone) of either transducer, and if so, which one? (speed of sound in water = 1.49 mm/ μ sec)
- b) Neglect the fact that the transducer response to rod targets in water may change with range, and assume that the average attenuation coefficient for ultrasound propagation in tissue is 1.0 dB/cm-MHz. Consider the attenuation of ultrasound in water to be negligible. Which transducer is more sensitive to a small rod target in vivo at a range of 17 cm and by how much?
- c) Qualitatively, how do the relative sensitivities calculated in (b) change when you consider the directivities of the transducers, i.e., the change in their response to rod targets in water as a function of range?

1978

PART II
DIAGNOSTIC

Points Problem 3

(3) Part A
 in a simple formula

Relate/the focal spot size (F) in mm of an x-ray tube, magnification (M) of a test object, and resolution (R) in line pairs per millimeter (lp/mm). Use this formula to draw the curve for resolution versus magnification for a focal spot size of 1 mm for M from 1.1 to 10.

(4) Part B

Give the limiting resolution (lp/mm) at an MTF of 0.1 which one would expect from the following imaging devices when exposed to x rays.

	<u>Resolution (lp/mm) at MTF = 0.1</u>
Medical x-ray film	_____
Slow (high detail) screens	_____
Medium (par speed) screens	_____
Fast (low detail) screens	_____
Cadmium zinc sulfide image intensifier	_____
Cesium iodide image intensifier	_____
Television with image intensifier	_____

(3) Part C

Use a simple diagram of a line source focal spot and a sinusoidal test object to show the resolution of the focal spot for an object placed
(1) adjacent to the focal spot and
(2) midway between the focal spot and the image plane.
Show the resolution in the imageplane for each of the above situations.

- 2 pts. a) For the idealized film/screen combination described by the characteristic curve shown in Figure one, write an equation for the segment between toe and shoulder. Define all terms.

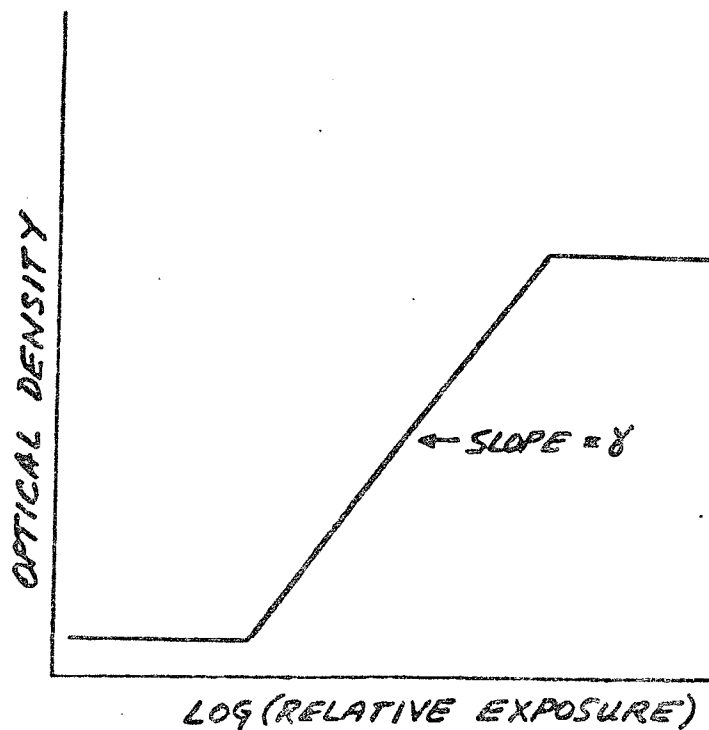

Figure 1

- 6 pts. b) Define image contrast, C_r , to be

$$C_r = \frac{I_{\max} + I_{\min}}{I_{\max} - I_{\min}}$$

Where I_{\max} = maximum light intensity transmitted through radiograph

I_{\min} = minimum light intensity transmitted through radiograph.

Assume that the relative exposure across a beam exiting an x-ray test phantom varies sinusoidally as depicted in Figure 2.

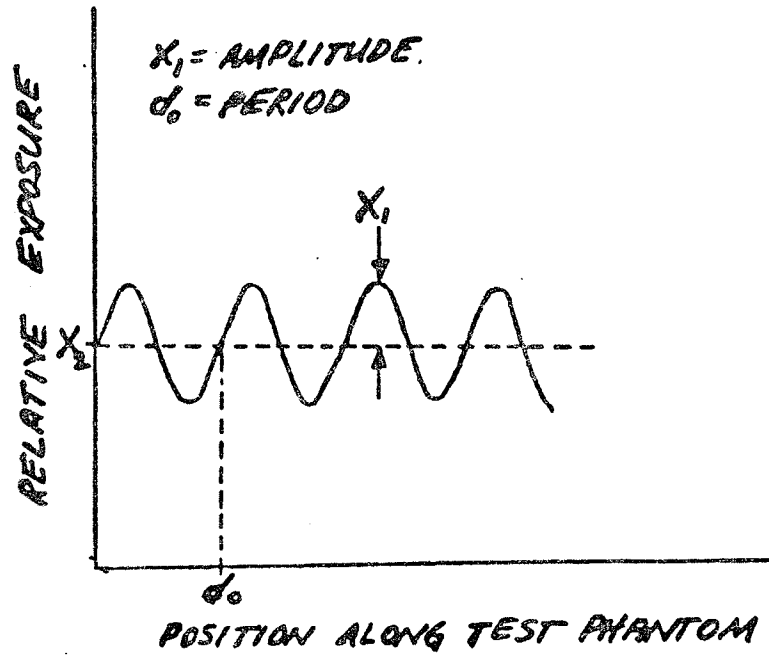

Figure 2

If the relative exposure axis in Figure 2 falls in the optimum imaging range of Figure 1 show that, using the film/screen combination in Figure 1, the image contrast of the test phantom is given by

$$C_r = \frac{(X_2 + X_1)^\gamma + (X_2 - X_1)^\gamma}{(X_2 + X_1)^\gamma - (X_2 - X_1)^\gamma}$$

2 pts. c) If subject contrast, C_s , is defined to be

$$C_s = \frac{X_{\max} + X_{\min}}{X_{\max} - X_{\min}}$$

Where X_{\max} = maximum exit exposure

X_{\min} = minimum exit exposure,

show that if $\gamma = 1$, subject contrast is not enhanced (i.e., image and subject contrast are the same). Also, explain why subject contrast is enhanced if $\gamma > 1$ and if $\gamma < 1$ why subject contrast is reduced.

You are asked to evaluate the resolution capabilities of two mammographic systems A and B with the following parameters:

SYSTEM A: No-screen film technique. 30 kVp, 1600 mAs.
Focal spot 2 mm square, uniform emission.
Focus-film distance 80 cm. Midplane breast to film distance 5 cm.
Film A.

SYSTEM B: Single screen/film technique. 30 kVp, 100 mAs.
Focal spot 0.6 mm square, uniform emission.
Focus-film distance 55 cm. Midplane breast to film distance 5 cm.
Film B.
Screen

- 4 pts. a) Derive the modulation transfer function (MTF) for the focal spot in systems A and B.
- 2 pts. b) Find the limiting resolution of the two systems, stating all assumptions.
- 4 pts. c) Discuss the relative advantages of the two systems.

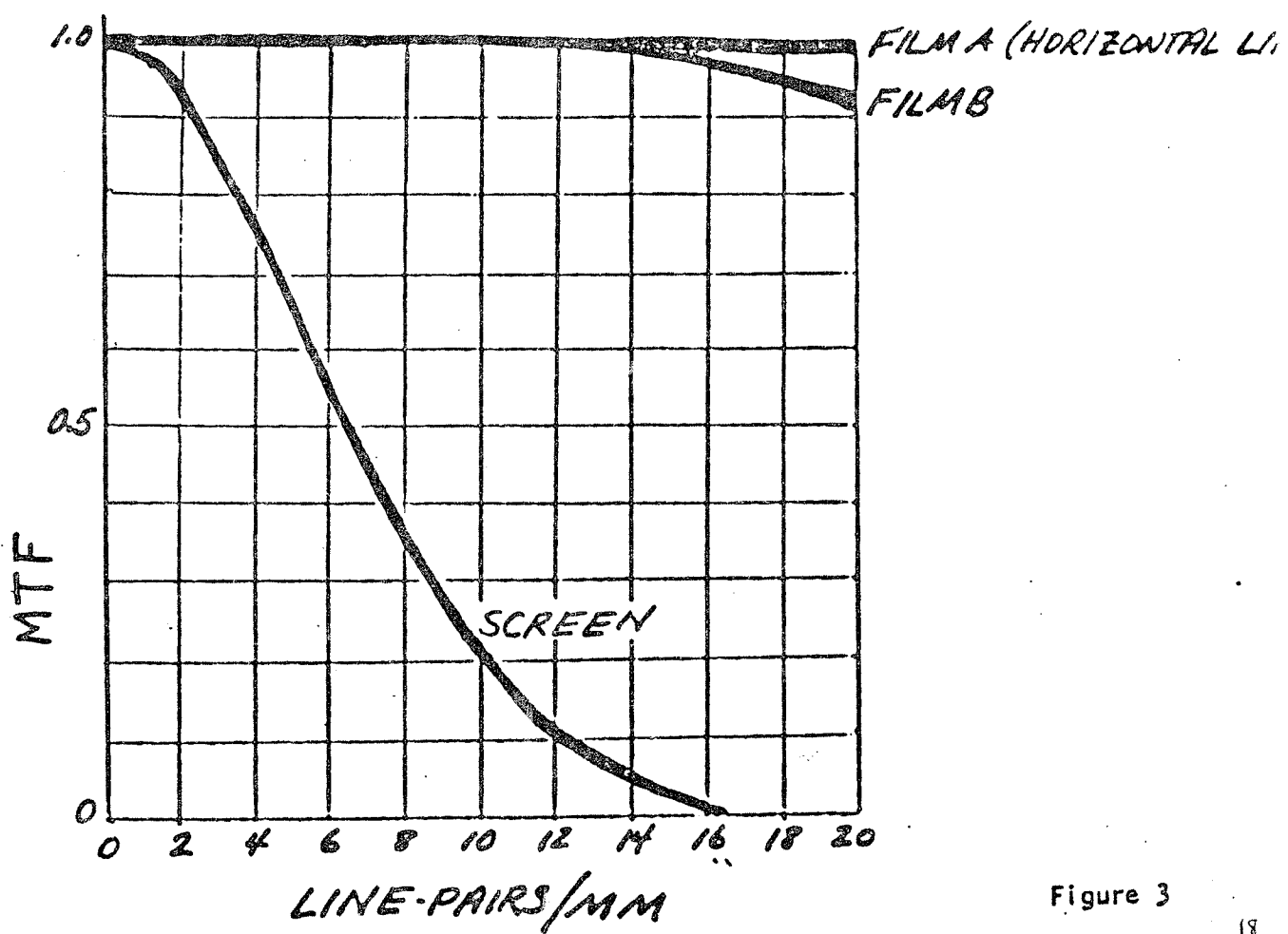

Figure 3

E
14

PART II
DIAGNOSTIC RADIOLOGICAL PHYSICS (PROTECTION)

All calculations should be shown and necessary assumptions should be stated on the answer sheet .

PD-1. The principal component of the radiation from xenon due to the decay of Cesium-131 is a 30-keV characteristic x ray. An ionization chamber survey meter gives a reading R_1 when placed at point P_1 at a large distance from a source of Xenon. The exposure rate at P_1 is I .

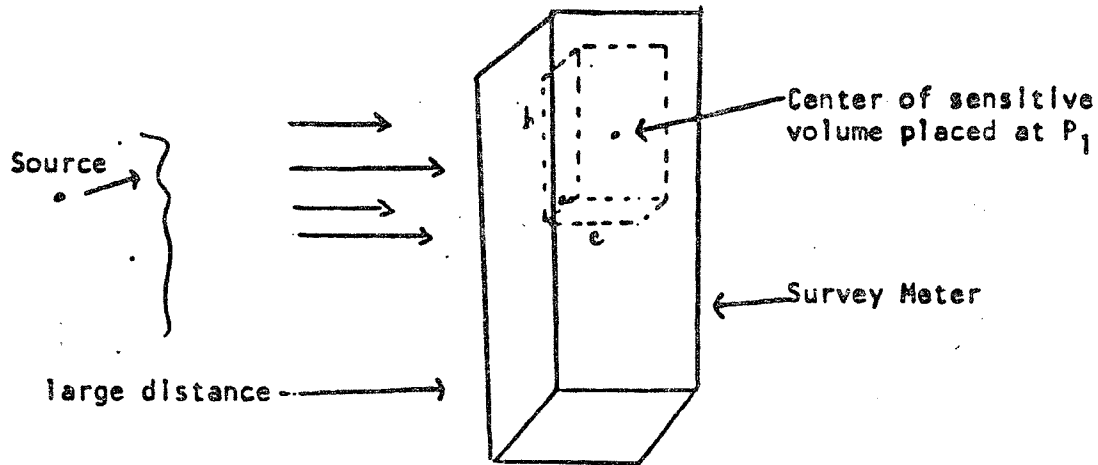

FIGURE 1

The survey meter is now placed above a lead shield containing another source of Xenon with a beam transmitted through a hole in the shield. The exposure rate at P_2 is J .

15

PART II
DIAGNOSTIC RADIOLOGICAL PHYSICS (PROTECTION)

PD-1. (Continued)

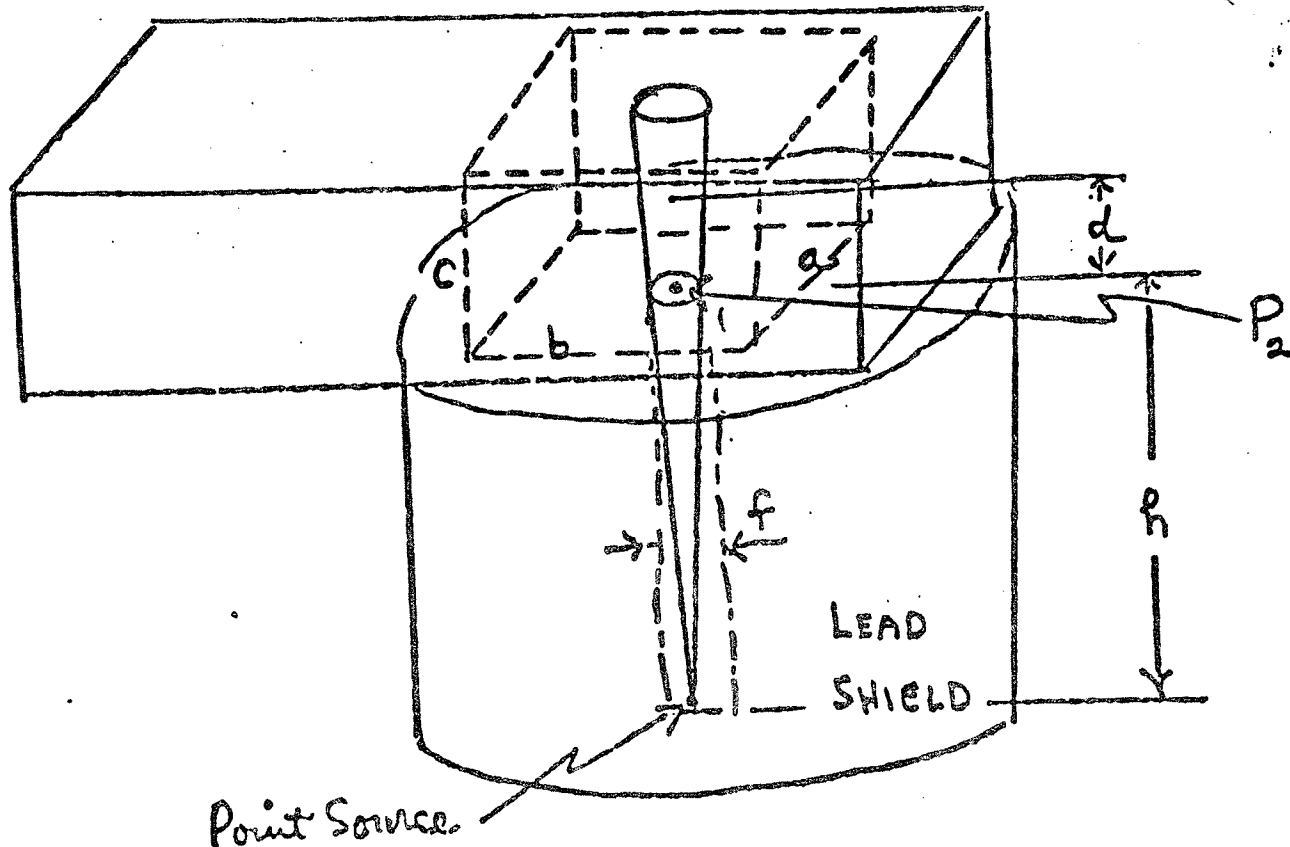

FIGURE 2

The distance from the center of the sensitive volume of the chamber to point P_2 is d . The diameter of the hole in the shield is f . What is the reading R_2 on the survey meter expressed in terms of the variables given? Dimension c is sufficiently small so that air attenuation is negligible.

1978

18 ✓
PART II
DIAGNOSTIC
PROTECTION

nts

Problem 5

A fluoroscopic unit with kVp-variable automatic brightness control has a choice of four current settings: A = 0.5 mA; B = 1.0 mA; C = 2.0 mA; and D = 4.0 mA.

-)
- a) Which of the current settings will produce the lowest exposure rate at the skin? Why?
-)
- b) If a pregnant woman with an A-P dimension of 20 cm receives 5 minutes of fluoroscopy for a barium enema examination at 100 kVp and 1 mA, estimate the fetal dose. Assume $\mu = 0.2 \text{ cm}^{-1}$ and make any other reasonable assumptions needed for your estimate.
-)
- c) In addition, eight 9" x 9" P-A spot films are made at 100 kVp and 20 mAs. Estimate the fetal dose from this procedure as well.
- d) Discuss the differences in the deleterious effects on the fetus most likely to occur as a function of the time interval between conception and time of examination for the following intervals: 1 week, 6 weeks, and 3 months.

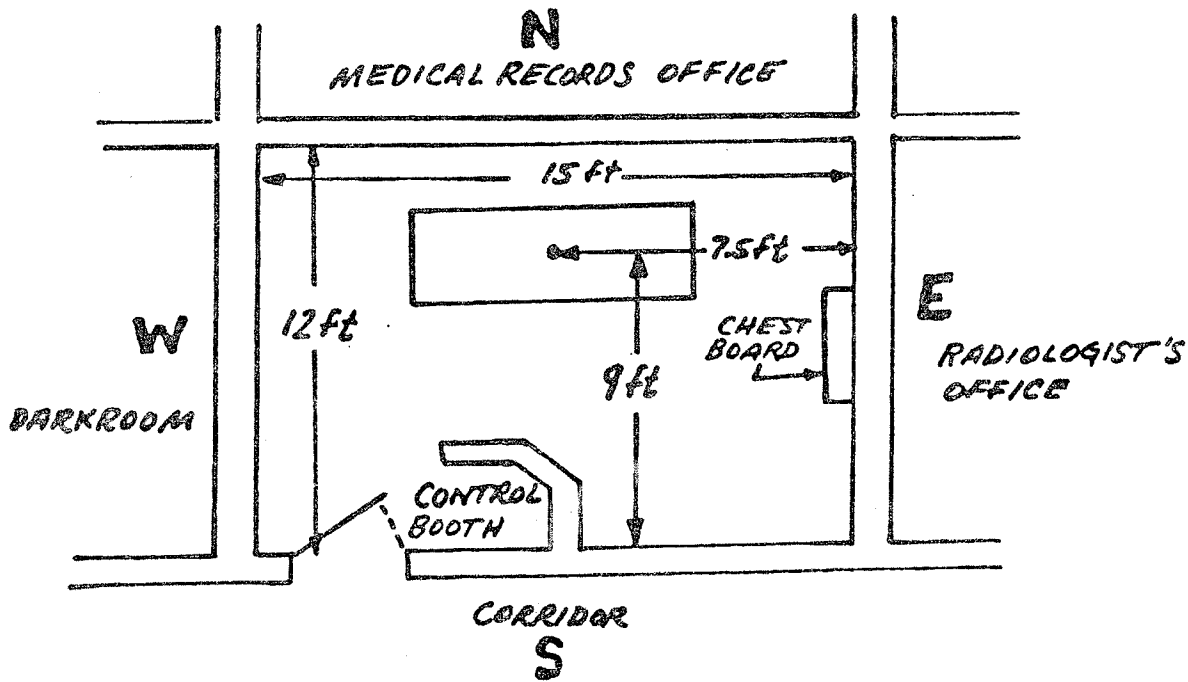

Figure 4

The general purpose radiographic room in Figure 4 above is operated at technique factors up to 125 kVp and 500 mA at a workload of 400 mA-min/week. With the exception of the Medical Records Office, all rooms and the corridor are controlled areas. Using the attached figure, assuming that the normal wall construction provides no attenuation, and justifying other reasonable assumptions wherever needed, estimate the minimum wall shielding for:

- ts. a) the east wall behind the chest cassette
- ts. b) the north wall for protection against cross-table lateral exposures
- ts. c) the west wall so that the exposure to stored film does not exceed the permissible level
- ts. d) the control booth for protection as a secondary barrier

(Figure 5 - NCRP Report 49 provided)

Fig 1, Annex D, NCRP 49 supplied

PART II THERAPEUTIC RADIOLOGICAL PHYSICS (PROTECTION)

Upon return to the storage area of an applicator following its removal from a patient, it is noted that one of the sealed radium or cesium brachytherapy sources is missing. Consider the situation as if you are the Radiation Protection Officer for the hospital and that the source may receive rough handling.

Part A:

Completely outline the procedures to be instituted in finding the source, including specification of the type of source and its activity.

Part B:

Describe the procedures to be instituted to estimate and evaluate the exposures and associated hazards to persons coming into contact with the source.

Part C:

What procedures were instituted to address the associated hazards delivered in Part B?

THERAPEUTIC RADIOLOGICAL PHYSICS

Part A:

Suppose one has a 20×20 cm beam of 20 MeV electrons striking a water phantom. With bone density = 1.5 g/cm^3 and lung density = 0.5 g/cm^3 , how far and in what direction would you estimate the 50% isodose line would shift if:

- (i) A one cm thick slab of bone were to replace the water between 1 and 2 cm depth?
- (ii) A one cm thick slab of bone were to replace the water between 10 and 11 cm depth?
- (iii) A two cm thick slab of lung were to replace the water between 1 and 3 cm depth.
- (iv) A two cm thick slab of lung were to replace the water between 10 and 12 cm depth?

Part B:

On the attached graph, draw the isodose distribution as accurately as you can for the 5, 50% and 90% isodose curves for electrons.

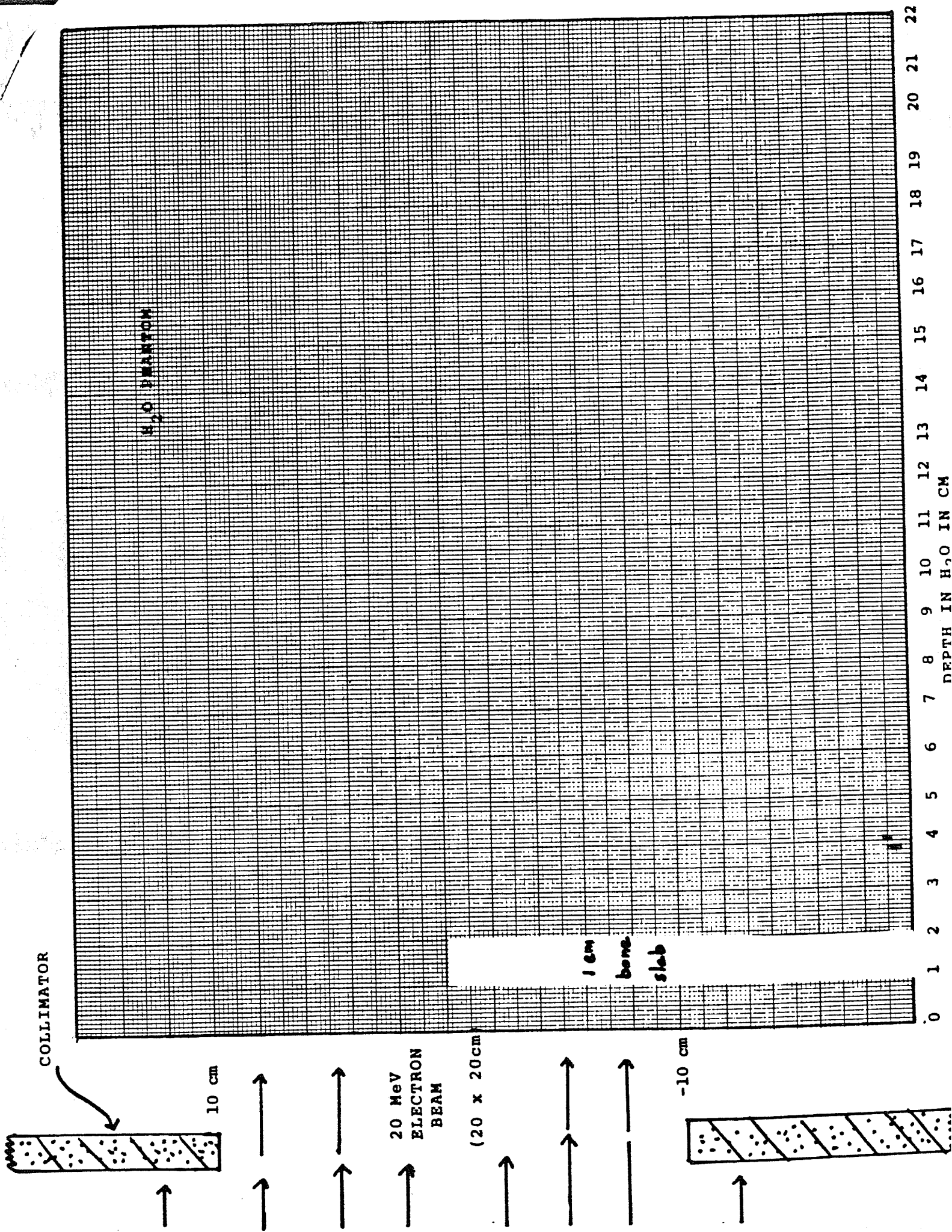

1977
PART II
THERAPEUTIC RADIOLOGICAL PHYSICS

24

T-1. SEE FOLLOWING TABLES-FIGURES

- a. A patient is to be treated on a cobalt unit with three 6×10 cm beams which intersect at T, the center of a tumor. The point T is 80 cm from the source and the dose rate in free space at this point is 85 rads/min. The depths of tissue above T for the 3 fields are 8, 12 and 15 cm respectively. Determine the dose rate at the tumor from each of the fields. Determine also the dose rate and beam size at the position of dose maximum for each of the fields. (Neglect inhomogeneities)
- b. If each of the 3 beams in this problem is to be applied for the same length of time, what is the total treatment time required to deliver 200 rads to the point T?
- c. If each of the 3 beams yields the same tumor dose, determine the appropriate times, the total time, and the maximum dose given each field for a total dose of 200 rads at point T.
- d. Identify possible advantages and disadvantages of these proposed plans.

PART II
THERAPEUTIC RADIOLOGICAL PHYSICS

25

⁶⁰COBALT TISSUE-AIR RATIOS

FOR USE BETWEEN 50 CM AND 100 CM (SOURCE-AXIS DISTANCE)

FIELD SIZE (CM \times CM) AT DEPTH

DEPTH CM	8x8	6x6	7x7	8x8	6x9	10x10	11x11	12x12
0.5	1.019	1.022	1.026	1.029	1.032	1.035	1.038	1.041
1	1.006	1.011	1.016	1.020	1.025	1.029	1.032	1.035
2	.966	.976	.984	.992	.998	1.004	1.009	1.013
3	.927	.938	.948	.958	.965	.972	.978	.983
4	.887	.902	.913	.924	.932	.940	.946	.952
5	.843	.859	.873	.886	.896	.905	.912	.918
6	.804	.821	.834	.847	.857	.867	.874	.881
7	.769	.776	.792	.807	.818	.829	.837	.845
8	.718	.736	.751	.765	.776	.787	.796	.805
9	.677	.695	.710	.725	.736	.746	.755	.764
10	.638	.655	.670	.685	.697	.709	.719	.729
11	.599	.615	.630	.644	.659	.673	.683	.693
12	.563	.580	.596	.611	.624	.636	.646	.656
13	.530	.548	.564	.580	.591	.602	.613	.623
14	.499	.515	.530	.545	.558	.571	.582	.592
15	.470	.487	.500	.513	.527	.540	.551	.562
16	.443	.458	.472	.485	.498	.510	.521	.532
17	.418	.432	.445	.458	.470	.482	.493	.504
18	.392	.406	.420	.433	.445	.457	.468	.479
19	.369	.383	.396	.408	.421	.434	.445	.455
20	.347	.361	.374	.386	.398	.410	.421	.431

26

PART II THERAPEUTIC RADIOLOGICAL PHYSICS

EQUIVALENT SQUARES OF RECTANGULAR FIELDS

Long axis (cm)	Short axis (cm)																											
	1	2	3	4	5	6	7	8	9	10	11	12	13	14	15	16	17	18	19	20	22	24	26	28	30			
1	1.0																											
2	1.4	2.0																										
3	1.6	2.4	3.0																									
4	1.7	2.7	3.4	4.0																								
5	1.8	3.0	3.8	4.5	5.0																							
6	1.9	3.1	4.1	4.8	5.5	6.0																						
7	2.0	3.3	4.3	5.1	5.8	6.5	7.0																					
8	2.1	3.4	4.5	5.4	6.2	6.9	7.5	8.0																				
9	2.1	3.5	4.6	5.6	6.5	7.2	7.9	8.5	9.0																			
10	2.2	3.6	4.8	5.8	6.7	7.5	8.2	8.9	9.5	10.0																		
11	2.2	3.7	4.9	5.9	6.9	7.8	8.6	9.3	9.9	10.5	11.0																	
12	2.2	3.7	5.0	6.1	7.1	8.0	8.8	9.6	10.3	10.9	11.5	12.0																
13	2.2	3.8	5.1	6.2	7.2	8.2	9.1	9.9	10.6	11.3	11.9	12.5	13.0															
14	2.3	3.8	5.1	6.3	7.4	8.4	9.3	10.1	10.9	11.6	12.3	12.9	13.5	14.0														
15	2.3	3.9	5.2	6.4	7.5	8.5	9.5	10.3	11.2	11.9	12.6	13.3	13.9	14.5	15.0													
16	2.3	4.0	5.3	6.5	7.6	8.6	9.6	10.5	11.4	12.2	13.0	13.7	14.3	14.9	15.5	16.0												
17	2.3	4.0	5.3	6.5	7.7	8.8	9.8	10.7	11.6	12.4	13.2	14.0	14.7	15.3	15.9	16.5	17.0											
18	2.3	4.0	5.3	6.6	7.8	8.9	9.9	10.8	11.8	12.7	13.5	14.3	15.0	15.7	16.3	16.9	17.5	18.0										
19	2.3	4.0	5.4	6.6	7.8	8.9	10.0	11.0	11.9	12.8	13.7	14.5	15.3	16.0	16.7	17.3	17.9	18.5	19.0									
20	2.3	4.0	5.4	6.7	7.9	9.0	10.1	11.1	12.1	13.0	13.9	14.7	15.5	16.3	17.0	17.7	18.3	18.9	19.5	20.0								
22	2.3	4.0	5.5	6.8	8.0	9.1	10.3	11.3	12.3	13.3	14.2	15.1	16.0	16.8	17.6	18.3	19.0	19.7	20.3	20.9	22.0							
24	2.4	4.1	5.6	6.9	8.1	9.2	10.4	11.5	12.5	13.5	14.3	15.4	16.3	17.2	18.0	18.8	19.6	20.3	21.0	21.7	22.9	24.0						
26	2.4	4.1	5.6	6.9	8.1	9.3	10.5	11.6	12.6	13.7	14.7	15.7	16.6	17.5	18.4	19.2	20.1	20.9	21.6	22.4	23.7	24.9	25.0					
28	2.4	4.1	5.6	6.9	8.2	9.4	10.5	11.7	12.8	13.8	14.8	15.9	16.8	17.8	18.7	19.6	20.5	21.3	22.1	22.9	24.4	25.7	27.0	28.0				
30	2.4	4.1	5.6	6.9	8.2	9.4	10.6	11.7	12.8	13.9	15.0	16.0	17.0	18.0	18.9	19.9	20.8	21.7	22.5	23.3	24.9	26.4	27.7	29.0	30.0			

All dimensions are in cm

TABLE II

1977
PART II
THERAPEUTIC RADIOLOGICAL PHYSICS

T-2. Given: Percentage depth dose Table III for Co-60 gamma rays 80 cm SSD

- a. If 100 rads were given to a 10 × 10 cm field at d_{max} (0.5 cm), how many rads would be delivered at a 10 cm depth? How many rads would be due to primary beam? How many rads would be due to scatter?
- b. If you were developing the above chart, how would data for "O" field be derived? Give three uses for "O" field size depth dose data.
- c. Would you expect the skin dose to be higher for a 20 × 20 cm field than a 10 × 10 field? Why?
- d. By what methods could you increase the tumor dose without changing the SSD or field size in a patient?

Co-60 %DD Table supplied



Wayne State University
School of Medicine

D.13 DOSIMETRY

(i) Briefly define or explain :

- | | |
|------------------|--------------------------|
| (a) photo-peak | (f) electronic avalanche |
| (b) dynode | (g) space charge |
| (c) W for air | (h) quenching |
| (d) glow curve | (i) coincidence loss |
| (e) Compton edge | (k) dead time |

(ii) Describe the following radiation detectors based on gas ionization and discuss their relative merits in the field of radiation protection:

- (a) ionization chamber
- (b) proportional counter
- (c) Geiger-Mueller (G-M) counter

How are these detectors calibrated to give readings in radiation quantities pertinent to radiation protection ?

(iii) Briefly discuss :

- (a) the calculation of absorbed dose in air from a measurement of ionization in air with an ionization chamber
- (b) the energy discrimination ability of proportional counters
- (c) how to distinguish between beta and gamma radiation with a G-M counter, and
- (d) how to determine source strength of a Beta emitter with a G-M counter.



Wayne State University
School of Medicine

D.14 DOSIMETRY

- (i) Describe the principles of operation of scintillation detectors and discuss their use in radiation protection.
- (ii) Draw a typical pulse height spectrum obtained with a NaI (Tl) scintillation detector and an encapsulated cesium-137 gamma source. Identify and explain the main features of the spectrum.
- (iii) Discuss the techniques used for obtaining pulse height distributions from beta emitters by means of liquid scintillation counting techniques.
- (iv) Thermoluminescent Dosimetry (TLD) is the most widely used relative dosimetry technique. Briefly discuss the main characteristics of a typical TLD reader and at least three materials used as radiation sensitive phosphors.



Wayne State University
School of Medicine

D.15 DOSIMETRY

Discuss the various protocols which have been designed for the determination of absorbed dose from high-energy photon and electron beams.

(I) For the TG-21 protocol explain the following terms:

- | | |
|-------------------------------------|--|
| (a) "directly traceable" to NBS; | (i) $(\bar{\mu}_{en}/\rho)_{wall}^{air}$ |
| (b) Co-60 calibration factor; | (j) β_{wall} ; |
| (c) N_{gas} ; | (k) W/e ; |
| (d) d_{max} ; | (l) A_{ion} ; |
| (e) build-up cap; | (m) N_x ; |
| (f) Bragg-Gray cavity; | (n) A_{wall} And P_{wall} ; |
| (g) J_{gas} ; | (o) A_{repl} And P_{repl} ; |
| (h) $(\bar{L}/\rho)_{gas}^{wall}$; | (p) E_0 . |

(II) How would you determine the collection efficiency of an ion chamber?

(III) Discuss the choice of ion chamber for the calibration of photon and electron beams of various energies.

(IV) Discuss the problems associated with the use of plastic phantoms for high energy x-ray beam calibrations.



Wayne State University
School of Medicine

E.1. RADIATION SAFETY.

(i) Briefly define or explain:

- | | |
|---------------------------------------|--------------------------|
| (a) maximum permissible dose | (f) radiation protection |
| (b) genetically significant dose | (g) Sievert |
| (c) relative biological effectiveness | (h) rem |
| (d) dose equivalent | (j) mutation |
| (e) quality factor | (k) LD _{50/30} |

(ii) Briefly discuss at least six methods which will reduce patient dose in diagnostic radiology procedures.

(iii) Describe the types of shielding required in an x-ray radiographic installation. State the information you would require to make an adequate barrier thickness calculation and indicate how you would perform the calculation.

(iv) Define the somatic vs genetic effects of ionising radiations and briefly discuss the sensitivity to ionising radiation of an embryo and fetus.

(v) Describe three common personnel monitors and indicate how the dose is estimated for each.



Wayne State University
School of Medicine

E.2 RADIATION SAFETY

- (i) Briefly define or explain :
- | | |
|------------------------------|---|
| (a) stopping power | (f) exposure |
| (b) half-value layer (HVL) | (g) absorbed dose |
| (c) characteristic radiation | (h) dose equivalent (DE) |
| (d) bremsstrahlung | (j) quality factor (Q) |
| (e) high LET radiations | (k) relative biological effectiveness (RBE) |
- (ii) Explain the difference in the method of measuring or designating "radiation quality" in radiobiology as compared with the description of a radiation therapy beam.
- (iii) Discuss the concept of linear energy transfer (LET) and its use as a measure of radiation quality. How does LET vary with the type and energy of charged particles and with depth in a medium in which charged particles are slowed down.
- (iv) Outline one radiobiological model proposed to describe the variation of relative biological effectiveness and/or shape of dose-response curve as a function of radiation type and energy.
- (v) Briefly describe the experimental evidence upon which the ICRP values of quality factor Q are based.
- (vi) What is the dose equivalent (DE) of an absorbed dose of 10 mGy for a beam of 10 MeV neutrons ?



Wayne State University
School of Medicine

E.3 RADIATION SAFETY

- (i) Define the exposure rate constant r , derive the relationship between r , photon energy $h\nu$ (in MeV) and the mass energy absorption coefficient $(\mu_{ab}/\rho)_{air}$ for air (in m^2/kg), and sketch r in the photon energy range between 10 keV and 10 MeV.
- (ii) Many radiation survey meters are currently calibrated in terms of roentgen units. Discuss the suitability of the exposure concept for radiation protection measurements. State the SI unit of exposure and give arguments in favour of one quantity that might be used as a replacement for exposure.
- (iii) Outline the basis of operation, the merits and the limitations of the following:
- the personnel dosimetry devices provided by any vendor of your choice
 - "remmeters" for neutron dosimetry
 - an instrument to measure the "dose equivalent index" as defined by the ICRU
 - a hypothetical device for measuring the whole-body dose equivalent rate (this may be either a device already proposed or one of your own design).
- (iv) Discuss the relationship between (a) particle fluence and (b) photon fluence and absorbed dose. Give approximate values for the particle or photon fluence of the following radiations corresponding to a dose equivalent of 1 mSv in water:
- cobalt-60 gamma rays,
 - 10 MeV electrons, and
 - 10 MeV neutrons.
- (v) Sketch typical depth dose curves in water for the following beams:
- | | |
|------------------------------|----------------------------------|
| (a) 100 kVp and 10 MV x rays | (d) 6 MeV and 18 MeV electrons |
| (b) cobalt gamma rays | (e) 100 MeV protons |
| (c) 14 MeV neutrons | (f) 50 MeV negative π mesons |



Wayne State University
School of Medicine

E.4 RADIATION SAFETY

(i) Briefly define or explain :

- | | |
|------------------------------------|---|
| (a) kerma | (f) pair production |
| (b) standard deviation | (g) thermal neutron |
| (c) precision of measurement | (h) recoil proton |
| (d) indirectly ionizing radiations | (i) elastic collision |
| (e) chemical dosimetry | (k) measurement of neutrons in the presence of x rays or gamma rays |

(ii) Discuss the methods, equipment and problems associated with measurements of dose equivalents from neutrons.

(iii) Discuss the effect of background radiation on the precision of radiation measurements.

(iv) Between the age of 40 and 50 a woman had the following examinations using ionizing radiations:

- a thyroid uptake and scan using 50 microcuries of I-131 with an uptake of 25%
- four mammograms (2 projections each breast)
- four long fluoroscopic examinations (PA at 150 kVp)

Compare the mortality risk from cancer resulting from these examinations to the risk of death from some other accepted hazard in modern society.

In each case state clearly your assumptions with respect to the examination.

(v) Discuss the dose equivalent limit (DEL) as defined by ICRP and explain the relationship between the primary DEL and other (derived) limits.

(vi) What is the dose equivalent limit (DEL) for stochastic effects arising from uniform irradiation of the whole body? Is the DEL modified when the whole body is irradiated non-uniformly? Give four examples of weighting factors.



Wayne State University
School of Medicine

E.5 RADIATION SAFETY

- (i) Briefly discuss the equipment and procedures used for an area radiation survey of the following new installations:
- | | |
|--------------------------------|----------------|
| (a) fluoroscopic/fluorographic | (c) dental |
| (b) radiographic | (d) CT-scanner |
- (ii) Briefly discuss the routine radiation protection procedures in nuclear medicine departments.
- (iii) A technologist works at a bench such that the lower half of her body (below the umbilicus) receives a negligible dose of radiation whereas the upper part of the body is exposed to a small sealed source of cesium-137. The annual exposure at the position of this upper part is 600 mR in the absence of the technologist. Estimate the whole-body dose equivalent. The recommended weighting factors are: gonads - 0.25, breast - 0.15, red bone marrow - 0.12, lung - 0.12, thyroid - 0.03, bone surface - 0.03, remainder - 0.30. State clearly any assumptions you have made in arriving at your estimate.
- (iv) Discuss the following personnel radiation monitors:
- (a) pocket ionization chamber
 - (b) film badge
 - (c) TLD badge
- Clearly state the energy response as well as the advantages and disadvantages of each technique.



Wayne State University
School of Medicine

E.6 RADIATION SAFETY

(I) In planning radiation facilities protection of three groups of people has to be considered:

- (a) radiation workers
- (b) non-radiation workers
- (c) public at large

Specify and justify the dose equivalent limits for the three groups and compare them to the dose equivalent from natural background.

(II) Briefly define or explain:

- | | |
|---------------------------------------|------------------------------|
| (a) genetically significant dose | (f) dose equivalent |
| (b) quality factor | (g) exposure rate constant |
| (c) collisional stopping power | (h) body burden |
| (d) LET | (i) dose equivalent limit |
| (e) relative biological effectiveness | (k) maximum permissible dose |

(III) Give the dose equivalent limit for

- (a) members of the public
- (b) occupational exposure of women of reproductive capacity
- (c) occupational exposure of pregnant women

(IV) A fetus is exposed to a dose of 5 cSv during the 10th week of pregnancy. Discuss the possible effect(s) of this exposure, and estimate the risk factors associated with each effect.



Wayne State University
School of Medicine

E.7 RADIATION SAFETY

(i) Briefly define or explain :

- | | |
|-----------------------|-----------------------------|
| (a) primary barrier | (f) workload W |
| (b) leakage radiation | (g) occupancy factor T |
| (c) scatter | (h) beam stopper |
| (d) secondary barrier | (j) tenth-value layer (TVL) |
| (e) use factor U | (k) ALARA principle |

(ii) Sketch a floor plan for a typical radiation therapy room, housing an isocentrically mounted cobalt unit.

- (a) Give and discuss typical values for W, T and U, as well as thicknesses for primary and secondary barriers.
- (b) Explain how the barrier thicknesses are calculated in practice and where the necessary information on transmission parameters is obtained.
- (c) Explain how and why the ALARA principle was taken into account when the room was designed.

(iii) Briefly discuss the rationale for the dose equivalent limits given in ICRP 26.

(iv) Discuss the equipment and procedure used for an area radiation protection survey of a new cobalt radiotherapy installation.



Wayne State University
School of Medicine

E.8 RADIATION SAFETY

(i) Briefly define or explain :

- | | |
|------------------------------------|----------------------------------|
| (a) critical organ | (e) ICRU and ICRP |
| (b) maximum permissible dose (MPD) | (f) partial exposure |
| (c) stochastic effect | (g) total body irradiation (TBI) |
| (d) non-stochastic effect | (h) radiation worker |

(ii) Derive an expression for the instantaneous dose rate averaged over an organ containing a uniformly distributed radioactive source:

- (a) β -emitter
(b) α -emitter

(iii) Discuss the concept of absorbed fraction for determining the absorbed dose delivered by an internal radioactive source.

(iv) Estimate the initial dose rate and cumulative dose to the liver delivered by a uniform concentration of $2 \cdot 10^4$ Bq/kg of ^{99m}Tc . Take the average energy per disintegration as 0.143 MeV, the physical and biological half-lives as 6.03 h and 20 h respectively, and the absorbed fraction as 0.15.



Wayne State University
School of Medicine

E.9 RADIOBIOLOGY

(i) Briefly define or explain:

- | | |
|---|---------------------------------|
| (a) oxygen enhancement ratio (OER) | (f) therapeutic ratio |
| (b) relative biological effectiveness (RBE) | (g) low LET particle |
| (c) linear energy transfer (LET) | (h) fractionated dose |
| (d) surviving fraction (SF) | (i) nominal standard dose (NSD) |
| (e) hypoxic cells | (k) time-dose factor (TDF) |

(ii) On a semilog plot show a typical example of a cell survival curve, clearly define its parameters and discuss its shape.

(iii) Compare and discuss typical cell survival curves for aerated cells vs hypoxic cells irradiated with: (a) x rays, (b) 14 MeV neutrons, (c) 10 MeV protons, (d) negative pions.

(iv) Complete the following table:

TYPE OF RADIATION	LET	RBE	OER
cobalt gamma rays			
electrons 6 MeV-50 MeV			
fast neutrons			
protons			
negative pions (peak)			

(v) Use the information given above to plot a diagram of OER vs LET and a diagram of RBE vs LET.

(vi) Briefly discuss the biological effects of ionizing Radiations with a special emphasis on:

- factors influencing somatic radiation effects
- genetic effects of radiations
- radiation doses to produce particular effects, such as induction of cancer and cataract, shortening of life-span, etc.
- sources of information regarding radiation effects
- effects of exposure during pregnancy



Wayne State University
School of Medicine

E.10 RADIOBIOLOGY

- (I) Briefly discuss the rationale for using hyperthermia as an adjunct to radiation therapy in treatment of cancer. State a few reasons for the speculation that heat may be more damaging to tumor cells than to normal tissue.
- (II) Discuss in detail at least three modalities currently used for production of hyperthermia.
- (III) Several parameters have been introduced to understand how hyperthermia can modify radiation response. Define the thermal enhancement ratio (TER), the therapeutic gain factor (TGF) and the thermal tolerance. Discuss the optimal temperature and time of heat exposure.
- (IV) Discuss at least three of the currently employed invasive thermometry methods for mapping of the temperature distribution in irradiated volume. Also discuss the temperature standards used to calibrate the equipment.
- (V) Several techniques for non-invasive temperature mapping have been proposed. Discuss the physical aspects of at least three of them.
- (VI) Discuss the important properties of phantoms for hyperthermia studies.



Wayne State University
School of Medicine

E.11 RADIOBIOLOGY

- (i) Briefly discuss the biological effects of ionizing Radiations with a special emphasis on:
- factors influencing somatic and genetic radiation effects
 - radiation doses to produce somatic effects on skin and in blood
 - radiation doses to induce cancer and cataract
 - effects of exposure to radiation during pregnancy
 - sources of information regarding radiation effects
- (ii) A patient is given a chest radiograph in the PA position;
- Estimate the minimum skin exposure required to produce a high-quality radiograph
 - Estimate the scattered radiation exposure received by a technologist standing at various points 2 m from the patient
 - If 200 films are taken per day what shielding is necessary for the room? Explain. State clearly any assumptions you have made.
- (iii) Discuss briefly why it is difficult to obtain accurate information on the biological effects on humans of low doses (e.g., 10 mGy) of low-LET ionizing radiations, especially if the dose is accumulated over a long period of time.
- (iv) One study indicates that in 243 women who received multiple fluoroscopies with an average dose to the breast of 12.1 Gy there were 23 additional cases of cancer of the breast. Estimate the risk of developing cancer as the result of a mammograph which gives an average dose of 2 mGy assuming
- a linear dose-response relationship
 - a linear-quadratic dose-response relationship in which the linear and quadratic contributions are equal at 1.0 Gy
- (v) Give approximate values for and discuss the genetically significant dose in North America due to the following:
- natural background (cosmic rays, external gamma rays and internal radiation)
 - nuclear power reactors
 - fallout from bomb tests
 - occupational exposure
 - diagnostic radiology and nuclear medicine



Wayne State University
School of Medicine

E.12 RADIOBIOLOGY

- (i) List the main components of the cell structure and briefly discuss their primary function in the cell.
- (ii) The primary agents that produce damage in cells irradiated by x rays or γ rays are high energy electrons liberated through interactions of photons with whole atoms, orbital electrons or nuclei. Briefly discuss the three most important modes of photon interactions with matter in the photon energy range between 10 keV and 10 MeV.
- (iii) Discuss the processes by which the high energy electrons produced through effects discussed in (ii) damage the biologically important molecules. Distinguish between direct and indirect action and comment on their relative importance.
- (iv) What is a cell survival curve? For a given type of radiation is the survival curve the same for all kinds of cells? Give examples of radioresistant and radiosensitive cell types.
- (v) Briefly discuss how cell survival is determined (a) in vitro (b) in vivo.



Wayne State University
School of Medicine

E.13 RADIOBIOLOGY

(i) Briefly define or explain :

- | | |
|---------------------|-------------------|
| (a) meiosis | (f) necrosis |
| (b) interphase | (g) metastasis |
| (c) S-phase | (h) exfoliation |
| (d) HeLa cells | (j) mitotic index |
| (e) growth fraction | (k) mitosis |

(ii) Discuss in detail the mitotic cell cycle and give three examples of cell cycle times for mammalian cells.

(iii) Briefly discuss at least two techniques which are used to produce synchronously dividing cell cultures.

(iv) Discuss the use of autoradiography in the study of cell cycle.

(v) Discuss the variation of radiosensitivity of a cell as a function of the position in the cell cycle (a) for photons (b) for neutrons.



Wayne State University
School of Medicine

E.14 RADIOBIOLOGY

(i) Briefly define or explain :

- | | |
|--------------|-----------------|
| (a) mutation | (f) cell cycle |
| (b) DNA | (g) anaphase |
| (c) FNA | (h) restitution |
| (d) LET | (i) chromatid |
| (e) RBE | (k) chromosome |

(ii) Discuss at least three types of lesions produced in DNA by ionizing radiations.

(iii) Discuss the radiation effects on chromosomes and list at least four specific examples of the damage. Explain the difference between chromosome and chromatid aberrations, and also discuss the effects of dose, dose rate and LET on specific types of chromosome damage.

(iv) Briefly discuss the effects of radiation on cellular constituents other than DNA and chromosomes.

(v) Briefly discuss three types of cell response to radiation :

- (a) interphase death
- (b) division delay
- (c) reproductive failure



Wayne State University
School of Medicine

E.15 RADIOBIOLOGY

- (i) The ultimate result of the interaction of radiation with water is the formation of ion pairs (H^+ , OH^-) and free radicals (H^{\bullet} , OH^{\bullet}).
- (a) Discuss the fate of ion pairs after irradiation.
 - (b) Discuss at least three reactions that the free radicals can undergo.
 - (c) Which water radiolysis product is believed to be the most damaging species to DNA ?
- (ii) Discuss the time scale for radiation effects from 10^{-14} s to 10^{-4} s following radiation energy deposition. At what times do the following events occur:
- (a) initial DNA damage by indirect action
 - (b) oxygen sensitization
 - (c) repair (various types)
- (iii) What is the "oxygen fixation hypothesis" ? Illustrate with equations, assuming that DNA is the most radiosensitive target in the cell. Show how sulfhydryl compounds are thought to provide a repair mechanism.
- (iv) Discuss the relative importance of DNA single-strand and double strand breaks.
- (v) Discuss the concept of target theory and its radiobiological implications.



Wayne State University
School of Medicine

E.16 RADIOBIOLOGY

- (i) Define the oxygen enhancement ratio (OER), discuss its dependence on dose, oxygen concentration and type of radiation, and give examples of survival curves for aerated vs hypoxic mammalian cells irradiated by :
- | | |
|---------------------|------------------------|
| (a) x rays | (c) α particles |
| (b) 14 MeV neutrons | (d) negative pions |
- (ii) Briefly discuss
- the importance of the oxygen effect in clinical radiotherapy
 - the rationale for radiotherapy with heavy ions
- (iii) Define and discuss the linear energy transfer (LET) and give typical values for
- | | |
|-----------------------------|-----------------------------|
| (a) 250 kVp x rays | (c) 14 MeV neutrons |
| (b) cobalt-60 γ rays | (d) heavy charged particles |
- (iv) Discuss the conceptual difference between LET and stopping power. Define and discuss the relative biological effectiveness (RBE) and its dependence on the type of radiation and on dose. Also discuss the effect of fractionated dose on RBE.
- (v) Describe and sketch the variations of (a) RBE and (b) OER with LET



Wayne State University
School of Medicine

E.17 RADIOBIOLOGY

(i) Briefly define or explain :

- | | |
|-------------------------|------------------------|
| (a) radiation exposure | (f) electron-hole pair |
| (b) low LET radiations | (g) Bragg peak |
| (c) ion pair | (h) free radical |
| (d) hydrated electron | (i) mean lethal dose |
| (e) specific ionization | (k) oxygen effect |

(ii) Derive and sketch mathematical expressions for

- (a) single hit
- (b) multi-target/ single hit survival curves

Clearly define the parameters and discuss the shapes of the two curves.

(iii) On a semilog plot show a typical example of a mammalian cell survival curve, label the axes and give typical numerical parameters of the survival curve.

(iv) Give at least two other mathematical descriptions of survival curves, define the parameters and explain the advantages over the curves given in (ii).

(v) Discuss the following factors affecting the response of cells to radiation and for each of these factors show with a sketch the effect they have on survival curves:

- (a) physical factors: LET and dose rate
- (b) chemical factors: radiation sensitizers and radiation protectors
- (c) biological factors: cell cycle and repopulation.



Wayne State University
School of Medicine

E.18 RADIOBIOLOGY

- (I) In vitro experiments with a new cultured mammalian cell line MGH indicate that aerobic cells demonstrate a typical radiation response with a D_{10} of 3.5 Gy and $n=8$.
 - (a) on the graph paper provided (semilog 5 cycles) sketch the survival curve for MGH cells irradiated in air;
 - (b) define and explain the terms: D_0 , D_q , n and D_{37} ;
 - (c) define the difference between D_0 and D_{37} .
- (II) Discuss OER in general and draw the survival curve for MGH cells irradiated in nitrogen [use same graph paper as in (I)] assuming an OER of 3.2.
- (III) Discuss four methods which have been used in radiotherapy in attempts to overcome the hypoxic cell problem.
- (IV) Hypoxic MGH cells containing 2 mM misonidazole, an electron affinic sensitizer, are irradiated with a dose of 20 Gy. The surviving fraction S is 5×10^{-3} . What is the enhancement ratio for 2 mM misonidazole?
- (V) Suppose that a tumor composed of 10^8 MGH cells had a 15% hypoxic fraction. Sketch roughly an in vivo survival curve for this tumor cell population.



Wayne State University
School of Medicine

E.19 RADIOBIOLOGY

- (i) Briefly define or explain the following concepts of tumor radiobiology:
- | | |
|---------------------------|-------------------------------|
| (a) hypoxic cells | (f) multiple daily fraction |
| (b) labeling index | (g) radiation sensitizer |
| (c) dose modifying factor | (h) radiation protector |
| (d) spheroid model | (i) accelerated fractionation |
| (e) hyperfractionation | (k) LD_{50} |
- (ii) Sketch a model of tumor cords showing capillaries and areas of hypoxia and necrosis. What is the concentration of oxygen below which cells are generally considered to be radiobiologically hypoxic? What is the diffusion distance of oxygen in tissue?
- (iii) Discuss the "4 R's" in radiobiology, and explain when they are important.
- (iv) Hyperthermia is sometimes considered as adjunct to radiotherapy:
- describe the phenomenon of *In vitro* cell killing by hyperthermia, give values of typical temperatures and exposure times, and sketch survival curves;
 - name at least three methods for administering hyperthermia *In vivo*;
 - name at least three methods of invasive temperature measurements during *In vivo* hyperthermia;
 - name at least two non-invasive temperature measurement methods investigated for use in clinical hyperthermia.



Wayne State University
School of Medicine

E.20 RADIOBIOLOGY

(I) Briefly define or explain:

- | | |
|-------------------------------|---------------------------------|
| (a) clonogenic cell | (f) dose per fraction |
| (b) sigmoid shape curve | (g) isoeffect curve |
| (c) split-course radiotherapy | (h) isodose curve |
| (d) hypofractionation | (i) nominal standard dose (NSD) |
| (e) fractionation scheme | (j) therapeutic ratio |

(II) Plot a typical dose response curve and explain what experimental data you need to obtain the curve for a typical example.

(III) Discuss and define the therapeutic ratio as used in radiotherapy. Elaborate on at least four techniques which are currently used or studied to improve the therapeutic ratio.

(IV) Discuss the implications of the Isoresponse (or Isoeffect) concept on the daily practice of radiotherapy.

(V) Discuss the Ellis' NSD equation, its usefulness and limitations in practical radiotherapy, and explain the reasons for the introduction of time-dose and fractionation factors (TDFs).

(VI) Survival of patients is the parameter of interest in studies of effectiveness of a particular radiotherapy treatment method. Discuss the information needed for these studies and explain the following survival curves:

- (a) crude
- (b) actuarial
- (c) Kaplan-Meier



Wayne State University
School of Medicine

E.21 RADIOBIOLOGY

- (I) Cataracts may be classified as delayed somatic effects of radiation.
 - (a) describe how cataracts develop in the lens of the eye as a result of exposure to ionizing radiation;
 - (b) describe the time/dose relationship for cataract production by x or γ rays;
 - (c) discuss the threshold for cataract formation and the effect of total dose on the latent period for cataract induction.
 - (d) compare the incidence of cataract following neutron irradiation with that seen following x or γ irradiation.
- (II) Briefly discuss at least six malignancies which may be induced by radiation in humans. Also name at least six sources of data on the incidence of radiation induced malignancies in humans.
- (III) Discuss the genetic effects of radiation in humans and explain the use of the concept of the doubling dose as the unit of measurement of the radiation effect. Also list the sources of genetically significant radiation and the average dose equivalent they contribute to the general population.
- (IV) Briefly describe the effect of radiation on the embryo and the fetus.
- (V) Discuss the acute effects of whole-body irradiation and give the radiation dose that would produce such effects.



Wayne State University
School of Medicine

F.1 ULTRASOUND

Ultrasound echoes are picked up by the transducer and converted into weak voltages. These received echo voltage signals then proceed through various portions of the signal processing chain in the equipment.

- (i) Draw a block diagram of the equipment circuitry and label all components.
- (ii) What is the first circuit component the echo voltages pass through? What is its function (why is it needed)?
- (iii) What is the second circuit component the echo voltages pass through? How many different operations are performed on the echo voltage waveforms in this component? List them and draw representative echo voltage waveforms before and after each operation. Can the order (sequence) of the operations be changed? Defend your answer.
- (iv) What is the next circuit component the echo voltages pass into? How are the echo amplitudes stored in this component? What process must be performed on the echo voltages before they can be stored? What is meant by echo amplitude resolution? How is good echo amplitude resolution obtained during the process of storing the echo amplitudes?
- (v) What is the next circuit component the echo signals pass into? How are the echoes handled in this component? Discuss all of the presently utilized methods for handling the echo signals in this component.
- (vi) In the final ultrasound clinical image what are the echo features that are used in the diagnosis of disease states in the body? Give a clinical example for each feature discussed.



Wayne State University
School of Medicine

F.2 ULTRASOUND

You are designing a single element mechanical sector scanner transducer. The design parameters are 5 MHz and a focal length of 15 cm.

- (i) What diameter piezoelectric crystal would you select and for what reason?
- (ii) What would be the length of the focal zone for this transducer?
- (iii) What would be the beamwidth at focus (at the focal length) for this transducer?
- (iv) Is this a practical transducer design for clinical scanning? Use two separate criteria in evaluating the clinical utility of this transducer.
- (v) Redesign the transducer (change its design parameters) to obtain a more clinically useful mechanical sector probe.
- (vi) Which parameter(s) would you change and what would be their new value(s)?
- (vii) What is the length of the focal zone for the new transducer?
- (viii) What is the new beamwidth at focus for the new transducer?
- (ix) How would you construct the transducer to assure good spatial resolution in the mechanical sector scanner images?



Wayne State University
School of Medicine

F.3 ULTRASOUND

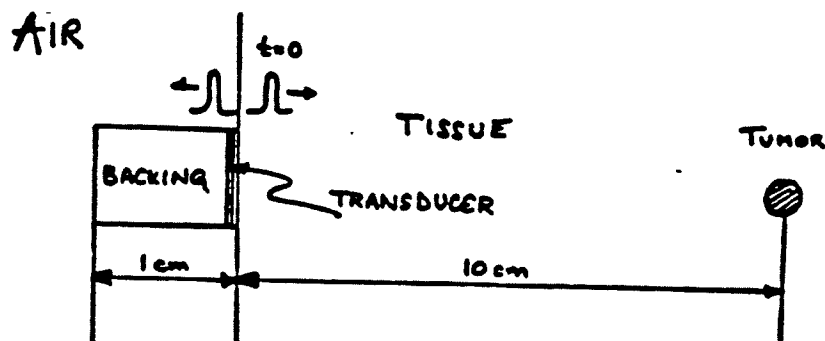

A very thin transducer is backed with a material 1 cm thick. This assembly is then placed on a patient 10 cm away from a fat-like tumour. When the transducer is excited, a primary ultrasonic wave of amplitude 1.0 enters the tissue. At the same time, a secondary pulse of amplitude 1.0 enters the "backing," travels in the "backing," is reflected by the "air-backing" interface, and propagates into the tissue. Calculate:

- (ii) the amplitude of the primary pulse at the tumor
- (ii) the amplitude of the secondary pulse at the air interface
- (iii) the amplitude of the secondary pulse at the tumour
- (iv) the relative magnitudes of the two pulses at the transducer after reflection at the tumour
- (v) What are the relative phases of these two pulses?
- (vi) What is the difference in time of arrival of the pulses at the transducer?
- (vii) What will be the appearance of the tumour in the image?
- (viii) What would you change to make the system better?

ULTRASONIC PROPERTIES OF VARIOUS MATERIALS

MATERIAL	$Z(\text{kg/m}^2\text{-s})$	$a(\text{dB/cm})$	$C(\text{m/s})$
tissue	1.63×10^6	1.	1540
tumour	1.38×10^6	0.63	1450
backing	34.0×10^6	10.	2000
air	$.004 \times 10^6$	12.	331



Wayne State University
School of Medicine

F.4 ULTRASOUND

- (i) What are A, B, C, and M mode ultrasound scans ?
- (ii) Name and discuss three techniques for obtaining "real time" ultrasound images.
- (iii) What three important factors affect the resolution of an ultrasound scanner ?
- (iv) Sketch, label and discuss briefly the structure of an ultrasound transducer.
- (v) What is meant by spatial peak temporal average (SPTA) ultrasound intensity ?
- (vi) What is the SPTA intensity of a typical ultrasound scanner ?
- (vii) Would a Doppler scanner tend to have higher or lower beam intensities than a conventional scanner and why ?
- (viii) In an ultrasound image, what are the characteristics of:
 - (a) a cyst ?
 - (b) a gall stone ?
 - (c) a malignant lesion ?



Wayne State University
School of Medicine

F.5 MAGNETIC RESONANCE

(i) Briefly discuss or define the following terms as they pertain to NMR imaging:

- | | |
|--|------------------------------|
| (a) Larmor equation | (g) spin echo technique |
| (b) gyromagnetic ratio | (h) chemical shift |
| (c) Curie's Law | (j) continuous wave |
| (d) $(1/2)\pi$ rf pulse | (k) fast Fourier transform |
| (e) spin-lattice relaxation time (T_1) | (l) free induction decay |
| (f) spin-spin relaxation time (T_2) | (m) rotating reference frame |

(ii) What is the range of magnetic field strengths currently used in proton imaging systems? What is the corresponding range of Larmor frequencies? Sketch and label the approximate relationship between T_1 and frequency and T_2 and frequency for this range. What is the relationship between signal-to-noise ratio and frequency for an NMR experiment and for an NMR imager?

(iii) Compare and contrast resistive and cryogenic magnets currently available for clinical NMR imaging. Include such factors as capital cost, stability, reliability, site requirements and operating costs.

(iv) What are the accepted limits on the RF power and magnetic field strength and rate of change in an MR imager, and on what physiological grounds are they set. What other "environmental" hazards must be considered when planning and operating an MR imager.



Wayne State University
School of Medicine

F.6 MAGNETIC RESONANCE

- (I) Describe with aid of diagrams the two-dimensional Fourier transform approach to NMR imaging. Produce and describe a timing diagram showing the rf and magnetic gradient signals required to produce a single two-dimensional image.

- (II) Describe, with the aid of sketches, the RF pulse and gradients, using ACR nomenclature, of the following imaging techniques:
 - (a) saturation recovery (partial saturation)
 - (b) inversion recovery
 - (c) spin echo

- (iii) Which techniques(s) from (ii) would you use to produce images with good contrast between tissues of:
 - (a) different T_1 ?
 - (b) different T_2 ?
 - (c) different proton density ?

For each example explain why the desired tissue contrast occurs.



Wayne State University
School of Medicine

F.7 MAGNETIC RESONANCE

- (i) Nuclei other than protons are routinely used in NMR experiments and have been considered for *in vivo* measurements. Why do some nuclei have magnetic moments while others do not?
- (ii) Make a list of at least five nuclei which could be useful *in vivo*. Expand your list to a table by including columns giving sensitivity at constant magnetic field, typical tissue concentrations, and combine these two columns to estimate detection sensitivity compared to protons (=1.0). Speculate on the possibility of NMR imaging of these nuclei.
- (iii) Sketch and label a typical ^31P NMR spectrum in muscle. If this type of spectroscopy is to be performed in an "imaging" magnet, what field strength, homogeneity, and temporal stability are required.
- (iv) Signal intensity in proton imaging can be influenced by factors other than proton density, T_1 , and T_2 . Describe how the following might produce clinically usable contrast in image:
 - (a) flow
 - (b) contrast agents (e.g., T_1 modifiers)



Wayne State University
School of Medicine

F.8 MAGNETIC RESONANCE

- (I) Contrast in MR imaging is based on relaxation time differences between protons in different tissues. In general, for a given imaging sequence, adjustment of the TE, the echo time, and TR, the sequence repetition time, determines the type of contrast (T1, T2, spin density) observed. Describe the kind of contrast observed in the following general cases: (a) long TE, long TR, (b) short TE, long TR, (c) short TE, short TR. Justify your answers in terms of the relaxation times of the protons.
- (II) Describe the five nuclear magnetic resonance relaxation mechanisms. What is the fundamental property of all the mechanisms which drive the magnetization back to thermal equilibrium? Which mechanism is most important for protons ($I=1/2$) and why? Which mechanism is most likely most important for sodium ($I=3/2$) and why?
- (III) (a) What is the equation of motion for the magnetization of an isolated non-interacting ensemble of spins in an applied magnetic field, B ? (b) Allowing spins to interact add additional terms to the equation of motion of the free spins to account for relaxation. (c) In NMR spectroscopy the equation developed in part (b) leads to what kind of behavior of the magnetization in the time and frequency domain? Give quantitative answers with regard to the terms which appear in the equation of motion. Consider the behavior of all of the components of the magnetization.

Oct 14, 1987

Dear Peter

I finished my ABR boards in Diagnostic Physics a week ago and thought I should send you the summary of questions asked.

For the four hour (first day) multiple choice, True-False, matching questions, we had 450 questions, about 100 multiple choice, 200 T-F, the rest matching. The multiple choice were first and were the most time consuming. I was able to finish the exam with about 25 minutes to spare and I then went back over the 15% that I had skipped because of complexity or because I didn't know the subject well enough to even guess intelligently. I ended up with very few blanks as a result of the extra time, and I caught several errors due to the panicky first few minutes.

On Biology, anatomy, physiology: we had no CT slices or images to match at all. We were asked to match the bones in the arm, identify skull bones by name, pick out tumor types that might occur in the lung, match body fluids with the organs where they are found, know which ~~type~~ veins carried oxygenated blood, what heart valves separated which

Chambers, and what purpose does the iris and cornea serve. Also they asked the number of vertebrae in each section and the type of tumors in the testicle.

On basic physics, know what quantities are associated with the Heisenberg uncertainty principle, be able to express joules, watts, momentum, pressure, etc in distance, time, and mass (about 10 questions). There were several Kerma, dose questions, and lots of electron capture, internal conversion, Beta + and - decay questions.

They did not ask about transient and secular equilibrium, ~~no~~ radiation safety limits, nothing on lp/mm, magnification, generators, cooling charts, nothing on types of MRI magnets, T1, T2, SE or FID (the first day), no CT at all except how to use CT for therapy planning, no computer questions except converting binary to octal, decimal and hexadecimal (also how many mega bytes needed for 30 frames of 512×512), nothing on fluoroscopy, tomography.

Statistics ate up about 40 questions (or it seemed that way). Two or three of these were on the median and what it was good for.

Several others matched statistical distribution and imaging modality. Another matched statistical tests, like χ^2 , Student, discriminant analysis with different experiments. Know what a mode is.

Electronics had another 40 questions. An OP-amp symbol was given and questions asked to label where input, output, etc was. Also identify wiring diagram symbols for transistors: PNP, diode, amplifier, rectifier, etc. Two problems in voltage were given, one DC, the other AC with capacitor, inductance and resistor in series (compute impedance). Then they gave RMS voltage and asked about KVP.

There weren't many ion chamber questions, ^{there ~~were~~ was} the usual one about what measuring device do you use for: radium needles, spill of seeds, x-ray leakage, etc. What is the purpose of the outside wall of the ionization chamber, what is good geometry for a chamber, and correct for resolving time in a counting problem.

There were about 7 questions on clinical mammography - what women were at risk for breast cancer, how often should women

over 50 be X-rayed, what were signs of a malignant lesion, etc.

There were only 15 or 20 radiation biology questions: the latent period of thyroid, leukemia, breast cancer; many of the questions were very similar to those in the RSNA Residents' syllabus.

There were about 20 neutron questions, some dealing with LET and neutrons, One question asked if any α , β or neutrons remained in a LINAC room ^{1 min.} after treatment.

Other therapy questions asked the depth dose of 1 MeV, Cobalt, at what voltage treatment, ~~Brachy~~ brachytherapy using the Parker tables, radium source to give a certain dose.

On MRI, they did ask the MHz of the RF response at 1.5T, the shielding, both magnetic and RF, in an MRI room.

Then in the idiotic question category, they asked what MHz did a microwave oven operate at, how high would a 100 gm ball be after 4 sec when it was thrown with a velocity of —, and how fast and what direction would a ball be going that had been spinning around on a string, when the string broke. We also

had the 200 lb man on ~~an~~ a scale in an elevator again,

There were about 30 on ultrasound - for instance, what signal level he turned if system dynamic range was 60 dB and output was 5V. The others were mainly transducer diameter and frequency problems - where is the focus, what is the resolution, how does attenuation vary with frequency, what does velocity depend on?

There were at least two cute questions about the ^{no. of.} digitization ^{bits} ~~rate~~ needed to keep the noise at -60 dB in a digital system, and another requesting the sample rate to match the ^{horizontal} resolution ^{to} a 525 line TV system.

Finally, there was a 3 vector problem that could have taken 10 minutes to solve - the trick was to pick the only possible answer from some multiple choices.

For the imaging questions the following day: The four I answered dealt with MRI, mammography, Digital filters, and QCA of digital display systems. If you want detail, I'll be glad to provide them, but I gather there is less interest in imaging questions.

Nov 2, 1987

Dear Peter

As an addition to the earlier letter I wrote you about the boards, this one concerns the four questions that I answered on the second day of the ACR tests in Diagnostic Imaging. The questions I didn't answer were computational ones on an II chain and on a safety problem.

The easiest question was a ~~four~~^{three} part question on mammography. 1. Given a graph of the TLD readings through a 6 cm breast at 1 cm intervals, compute the mean glandular dose (4 pts). 2. What are the advantages of Xeromammography over film-screen mammography. (3 pts) 3. In what way do mammography grids differ from other body part grids? (3 pts)

The MRI question also had three parts divided into 4, 3, and 3 points. The 4 point one was a derivation of an expression for T1 from an Induction Recovery sequence. It required taking the log of the Bloch equation and substituting $TE = 2\tau$. The second part was a practical question about TE, TR values for T2 and T1 weighted images and the last concerned discussing some ways

to speed up MRI scans.

The remaining two questions dealt with digital systems. The first one was all about digital filters - what was a filter? What were global, local, point filters? Give examples. Define a high pass filter. What kinds of Radiographic equipment produced digital images that filters could be used on? Draw a digital imaging chain -

Finally, the last question I probably shouldn't have tried, but it intrigued me because our service engineers ignore it. The question asked "Describe Quality Control procedures for the Display equipment associated with Digital images" I assume that they are referring to the TV monitors and multi-format cameras we have distributed in ultrasound, CT, MRI, DSA and Digital Radiography and so I did a quick and dirty description of what quick checks one might do on these units.

I keep having flash backs about this exam - did I remember to include this, did I do that computation right, etc. I hope this eventually stops

Diagnostic Physics Examination Part II
1988

(Choose three from the first four questions)

1. You are asked to provide performance specifications for a new film/screen mammography unit to be used for both magnification and screening:

- A. State the performance specifications for the power rating of the generator, kV range and increment, tube current range, focal spot sizes, source to film distance, grid ratio, and film sizes.
- B. A pinhole camera image for a 0.1 mm focal spot appears as shown below:

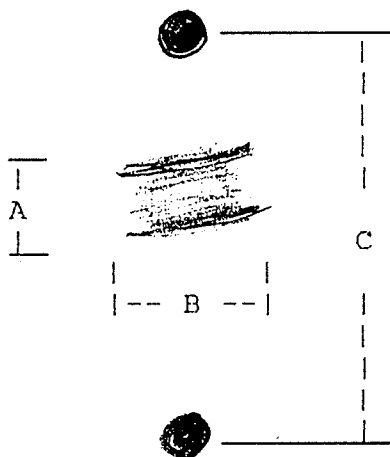

The image was obtained at the chest wall edge of the x-ray field from a pinhole camera with a 0.03 mm aperture. The real distance between the holes (measured in the object plane) is 1.25 cm. Which dimension (A or B) is parallel to the cathode-anode axis of the x-ray tube? Give a mathematical formula for calculating the true focal spot size in each dimension.

- C. What three methods can be used for measurement of focal spots? Explain the advantages and disadvantages of each.
- D. Is the focal spot size shown in part C above excessive? If so, what steps do you take to correct the problem?

2. A $m \times n$ digital image is represented by the function $I(m,n)$. Let $I(m,n)$ be the final output image on the display device.
 - A. Draw a graph that demonstrates the process of windowing and leveling.
 - B. Give a mathematical equation for the process of windowing a leveling relating the input image to the displayed gray level image.
 - C. Draw a 3×3 filtering kernel and give the numeric values that will result in a point smoothing operation. How do you avoid overflow of the resulting image? Show the kernel for a gradient (edge detection) operation that is independent of direction. Show the kernel for a gradient enhancement operation.
 - D. Write down the mathematical equation that represents convolution of a filter function (kernel) with the original input image.
3. Pulse sequences for MRI images. ???
4.
 - A. What is low contrast resolution?
 - B. How do you measure low contrast resolution in a fluoroscopic imaging chain? What are some typical values for low contrast resolution measured in this way?
 - C. Describe the components of a fluoroscopic imaging chain. Which ones affect low contrast resolution?
 - D. How do the components listed in part C affect low contrast resolution?
 - E. Describe how you would measure the low contrast resolution of each of the components listed above. Which would you check first?

Diagnostic Protection (Choose one question)

1.
 - A. What dose do you report to satisfy JCAH guidelines for the following types of units: a CT scanner, a mammographic unit, a dedicated chest unit, and a fluoroscopic unit.
 - B. Explain how you would measure each of the above.
 - C. What type of instrumentation would you use to make these measurements?

2.

During an emergency, a nurse holds a child while an abdominal x-ray is taken. No apron is worn by the nurse. A few weeks later, the nurse discovers that she was two weeks pregnant at the time of the exposure.

 - A. What are the approximate technique factors used for pediatric abdominal x-ray.
 - B. Calculate the fetal dose given a technique factor of 70 kVp, and 25 mAs (seemed like a giveaway for part A to me)
 - C. What actions would you recommend to the nurse? What do you tell her about the likelihood of deleterious affects on the fetus?
 - D. How would your recommendations change if the nurse were 1) 6 weeks pregnant at the time of the exposure and 2) 10 weeks pregnant?

Questions for ABR Written Examination of October 1988:

Part I:

A lot of questions on statistics, e.g. Chi square, t-test.

M.R.I. - expected gyromagnetic ratios for typical elements.

Nuclear Medicine - counting, scintillation.

Given the melting point of W in celsius, what is temperature in Fahrenheit.

Electronics - identify op amp circuitry, etc.

Define G value relative to length, mass and time.

DeBroglie wave equation; define and use Heisenberg principle.

Lots of physiology questions! tidal volume, residual volume, etc.

What are BEIR III values for air-plane travels; background for New York and Denver, etc.; risks of leukemia, etc.

Expected gravity for New York, North Pole, etc.

Calculate the linear attenuation coefficient for 2 compound mixtures. Given mass attenuation coefficient of A (25%) is $0.2 \text{ cm}^2/\text{gm}$ and B (75%) $0.3 \text{ cm}^2/\text{gm}$. Density of mixture is $1.5 \text{ gm}/\text{cm}^3$.

Calculate the wavelength of Compton scatter photon with initial energy 65 KeV scattered through 90° in Angstrom units.

Total of 425 questions in 4 hours.

About 125 questions are multiple choice, 125 are "pseudo" matching and 125 true/false.

It took me about 2.25 hours to do the first 125, 1 hour for the "pseudo" matches and 45 minutes for the true/false. I thought I did not have enough time after doing the first 125. However, I caught up by the time I hit the true/false because they went very fast.

However, Part II was a different story.

Part II (Therapy):

- 1.) A.) Discuss what is a "uniform" tumor dose distribution for a pelvis case. Give typical values.
- B.) Draw the isodose curves for a 3-field, 4 field and arc rotation for a pelvis case. Use isocentric technique.
- C.) Draw the expected dose distribution for a 3-field central brain tumor. What is the expected weighting using ^{60}Co given the following:

	Field Size	Depth
Coronal	6 x 6	11 cm
Right	6 x 6	6 cm
Left	6 x 6	6 cm

^{60}Co Table given.

- 2.) A.) Given ^{60}Co TAR table:

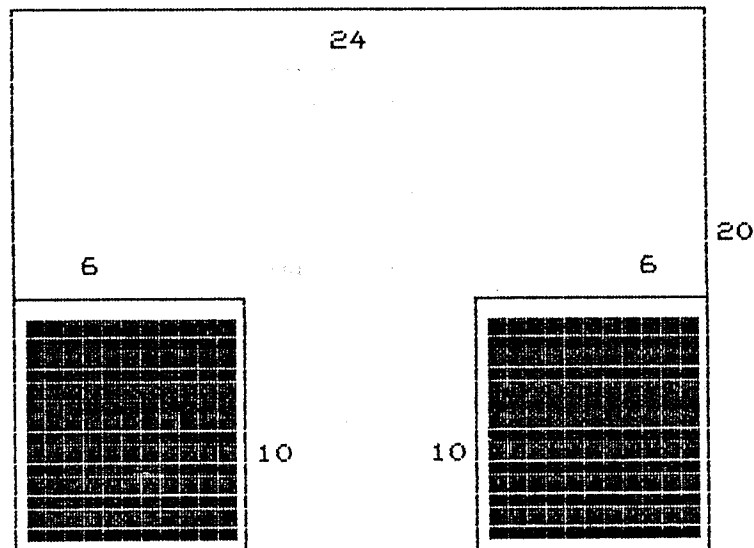

Calculate the time for the above field size at d_{11} . Given the "output factor in air" for 20 x 24 is 1.04. Tray factor is 0.97. Shutter correction is 0.02 minutes to be added after the calculated time. Dose rate is 159.3 cGy/min. for a 10 x 10 cm².

- B.) What is the percentage difference in time for the blocked field and the open field.

3.)

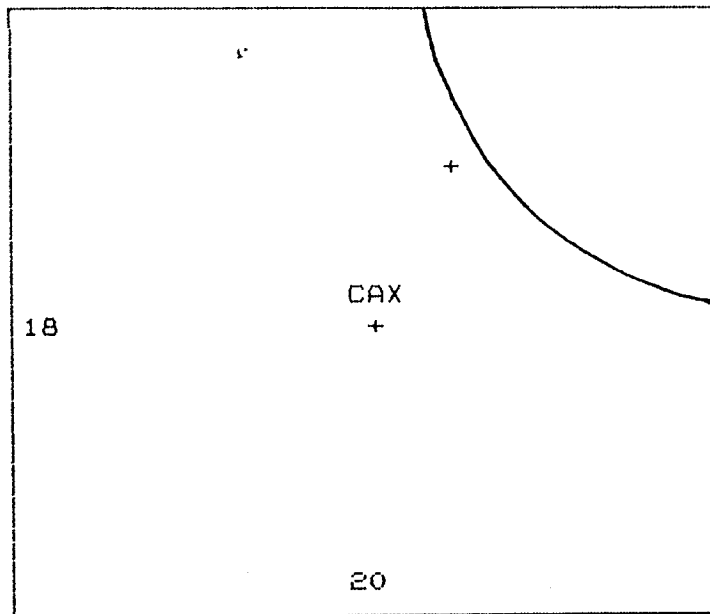

A.) 4500 cGy is given at midplane to the above field, given the following (using ^{60}Co):

	SSD	Separation
CAX	68	12
Supraclavicular	73	7
Inferior border	68	12

What is the expected dose to the supraclavicular at d_3 . Assume $\text{OCR} = 1$.

B.) The patient was found to have a recurrence, and another 1500 cGy is planned to be delivered at d_5 single field. How would you advise the radiotherapist to treat. Would you use ^{60}Co , 10 MV photon or electrons? Why?

C.) The patient was found to have metastases to the spinal cord below the lower border of the field. How would you advise the therapist to treat this field?

4.) Discuss treatment of a total body irradiation. What are the precautions, etc.

5.) ^{137}Cs tubes given with length and activity. Calculate dose to the therapist fingers and thumb during an implant. What are the precautions to be taken, etc.

6.) A.) Calculate the scatter to the north wall. Given a table of scatter factors and TVL in cm concrete for 20 MV linear accelerator.

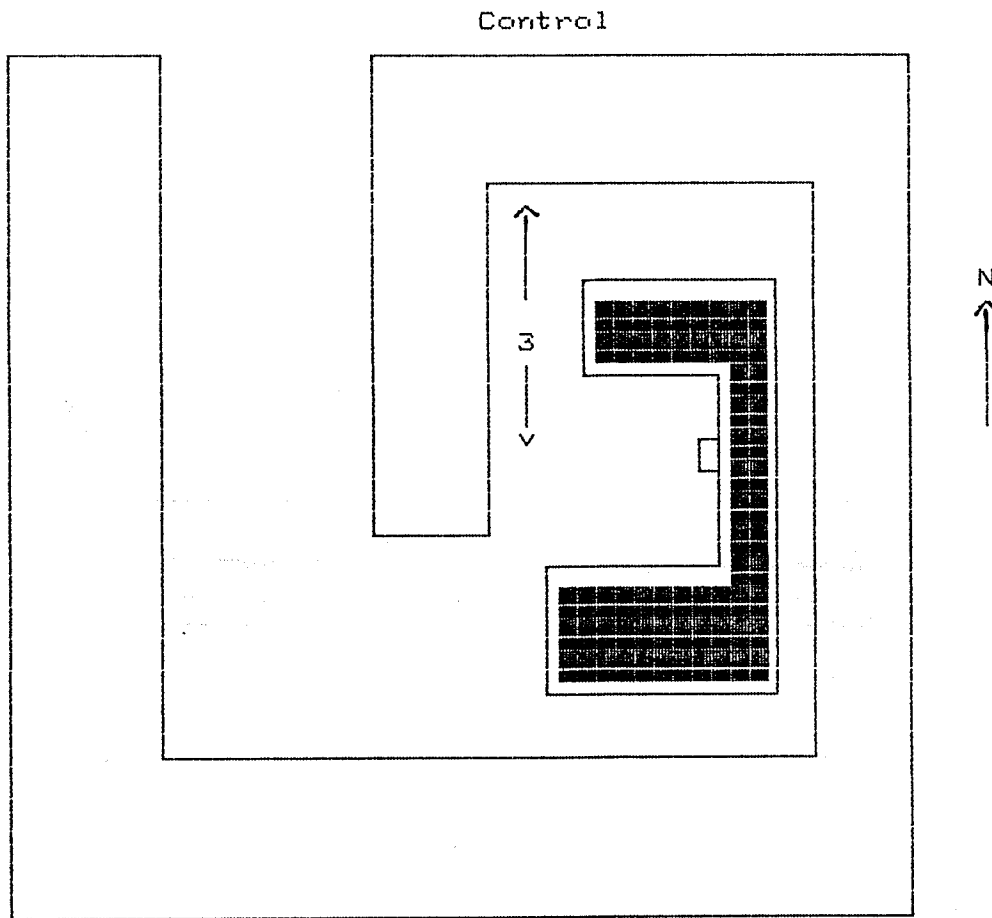

B.) Define workload and use factors. What are typical values.

C.) Discuss neutron considerations for the above as compared to low energy. What material is used for the door, etc.

There was not enough time for me to finish Part II, particularly the protection question. I should have done that first because I understand that you have to pass the protection question to pass Part II.

Postscript: Looks like my fear was unfounded because I passed all parts!

12/19/89

Peter Rosemark, Ph.D.
Cedars-Sinai Medical Center
Radiation Therapy Department
8700 Beverly Blvd.
Los Angeles, California 90048

Dear Dr. Rosemark:

I am enclosing \$ 25.00, payable to the ^{*Southern California*} ~~Southern~~ Chapter of the American Association of Physicists in Medicine for the American Board of Radiology Certification Study Guide for Radiological Physics. Below I am enclosing the notes of what I remember from the Diagnostic Radiological Physics and Medical Nuclear Physics Sections:

Diagnostic Radiological Physics:

- 1) Know BRH guidelines regarding amount of filtration required and dose allowances under the support plate for mammography.
- 2) Know the meaning of the Wiener Spectrum and how to interpret and use the spectrum.
- 3) Know how to use decision criteria curves to find false positive/true positive ratios.
- 4) Know how to calculate the focal length of a cine lens.
- 5) Know all framing modes and names.
- 6) Describe the difference between third and fourth generation CT Scanner Configurations.
- 7) Calculate a barrier problem using K_{ux} .
- 8) Calculate the penetration and reflection of a 5 MHz ultrasound beam in a kidney. Know penetration and reflection formulas.
- 9) Know Rose's signal/noise criterion for determining a structure.

- 10) Calculate number of light photons emitted from a 50 kvp X-ray. Information not given is the wavelength of light emitted from an ortho screen.
- 11) For the B scan ultrasound mode, what affects the aliasing of images.
- 12) Know the f-factor in bone, tissue and fat for 60-120 kev.
- 13) Calculate the bucky factor, grid factor and transmission factor and the relationship between them.
- 14) Know the wavelength of light for various intensifying screens.
- 15) Calculate the average gradient and gamma for a film-screen combination.

Medical Nuclear Physics:

- 1) Review Tracer Kinetic Modeling
- 2) Review RIA
- 3) Review Shilling test, and Cr-52 labeling.
- 4) Calculate gamma for a 150 kev photon, .33 emissions/dis.
- 5) Know regulations regarding % accuracy of dose calibrator, % Moly allowed in Tech, and % Al allowed in Tech.
- 6) Know the modes of isobaric transmutations.
- 7) Review and perform internal dose calculations; review definitions, esp. absorbed dose fraction and specific absorbed dose fraction.
- 8) Know the features of a Cs-137 curve in a well counter.
- 9) Know the relationship between fwhm and an MTF curve.
- 10) What is the real part of $1,0,0,0$ Fourier function.
- 11) What affects the noise found in SPECT.
- 12) What is the Kell Factor.

13) Know NRC regulations regarding quarterly rad safety meetings, dilutions for dose calibrator accuracy, daily wipe tests, etc.

14) Know about heart gating for SPECT.

15) Calculate blood flow using labeled red cells.

16) During end diastole, are the ventricles filled.

17) Review PET, know the sources of noise in PET and how to address them.

I realize these notes are somewhat haphazard. I remember only a few specific questions, so I hope these are of some help.

Sincerely yours,

1,

Physics Section Topics. Thursday afternoon, 4 hours.

Maxwell's theory.

Transformers and their windings.

Nuclear Medicine Counting Statistics.

Binary, Octal and Hexadecimal notation (No conversions).

Lots of diagnostic radiology questions.

Free falling bodies: if a bullet is shot horizontally, how far does it go before it hits the ground.

Op Amp Circuitry: 1) identify the parts of the circuit
2) given R2 and R1, what is the gain

Optics, a lens question.

What type of laser is mounted on the CT Scanner?

From 5 answers given, pick out three of the bones of the ear

Bones of the hand, arm, "shin"

Name the order in which the valves of the heart receive blood.

Identify which veins carry oxygenated blood.

Quantum mottle.

Grid ratios.

Is DO equal to the slope of the survival curve?

Regions of the G-M tube curve.

Computer memory calculation.

Therapy Physics Section Topics. Friday morning, 3 hours.

Many, many shielding questions dealing with Tenth Value Layers and Half Value Layers!!!

Head leakage in CO-60 and in CS-137 therapy units.

Wipe testing of CS-137 needles and CO-60 gantry.

Detectors - which ones are used for which situations and for which sources?

Definition of a misadministration. (Given a situation, would it be considered a misadministration. For example, a patient has a prescription for CO-60 but is treated on a Linac. Is that a misadministration?)

Cobalt-60 SSD calculations and TAR Calculations for doses.

Linac SSD calculations and TMR Calculations for doses.

Brachytherapy Safety. For example, given a patient with 80 mg Ra Eq, what values would you expect to detect in the patients' room, in the hallway, in the adjacent patients' lounge. Are the values reasonable and acceptable?

Temperature and Pressure Correction factor calculation.

Given a 5% shadow block in the center of a 12 x 12 field, what will be the %DD at 7 cm depth on the Central Axis?

What is the microwave frequency of a Linac?

TG-21 Questions.

Do you need to wipe test the Uranium depleted collimators on a Cobalt-60 machine?

Given an AP and a Lateral view of two points, A and B, calculate the distance between them.

Barometer questions. If you are a traveling physicist and you go from region A to region B, should you recalibrate if your barometer goes around 1 full rotation while you are traveling? How do you compare barometric readings at two locations? Should you use another facility's reading of barometric pressure if there is a storm between your facility and theirs?

Convert temperature in degrees F to degrees K.

What is the ideal set-up for Total Body Irradiation? A moving source and a stationary patient? A stationary source and a moving patient? Multiple adjacent fields?

What SSDs should be used for the film and for the build-up material when checking light field and radiation field coincidence on a CO-60.

What is the largest source of error in a CO-60 calibration or calculation? Temp & pressure Correction? Monthly decay? etc.

When you rotate the gantry of a Linear Accelerator, what should be the radius of the sphere that contains the isocenter?

Given a picture of Points A, B, C, and D which lie along the path of a beam which encounters a tissue-bone-tissue interface, where is the dose highest, is a point in bone receiving more dose than a point in tissue?

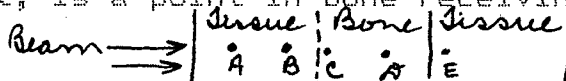

Calculate the collimator rotation angle for the brain fields of a medulloblastoma patient given the spine field length & SSD.

Calculate the gap between two adjacent fields.

Calculate penumbra for a Cobalt machine.

Part I: Study Guide

FOREWORD

Part I of the ABMP examination is intended to test general knowledge of the basic principles of medical physics. These are the principles with which all medical physicists should be familiar, regardless of their specialization. Questions will be restricted to basic principles only, not the finer details. Detailed questions will be in the appropriate Part II examinations.

The number of questions in the examination will be apportioned according to the following schedule:

1) Basic radiological physics:	20%
2) Radiation detection and measurement:	12%
3) Biology and radiobiology:	10%
4) Radiation protection:	11%
5) Statistics:	5%
6) Imaging and other diagnostic studies:	14%
7) Principles of therapy:	9%
8) Medical electronics:	6%
9) Medical applications of lasers:	3%
10) Anatomy, physiology and medical science:	7%
11) Computers:	3%

For Part I, four question formats will be used: A, B, K, and S. An example of each of these is given in the Appendix.

This Study Guide was prepared by members of the Part I Examination Panel: Colin Orton, Chairperson, Harry Astarita, Susan Barish, Gerry Shapiro, Sal Vacirca, and Shirley Vickers.

APPENDIX

SAMPLE QUESTIONS OF TYPES A, B, K, AND S

TYPE A

The average annual collective dose equivalent in mSv from natural sources (excluding radon) to the population in the USA is about:

- A. 0.1
- B. 0.5
- *C. 1.0
- D. 2.0
- E. 3.0

TYPE B

Match the property (1-4) with the appropriate particle (A-E)

- A. Proton
- B. Neutron
- C. Electron
- D. Neutrino
- E. Pion

- 1. Has the greatest mass (B)
- 2. Has rest mass of 140 MeV (E)
- 3. Has no charge and rest mass of 939 MeV (B)
- 4. Electron capture reduces the number of these in the nucleus (A)

TYPE K

Within hours of receiving a nearly lethal whole body dose of radiation an individual is likely to experience acute radiation syndrome symptoms which include:

- 1. nausea and diarrhea
 - 2. convulsive seizures
 - 3. severe fatigue
 - 4. loss of hair
- A. (1,2,3 only)
 - *B. (1,3 only)
 - C. (2,4 only)
 - D. (4 only)
 - E. (All are correct)

TYPE S

A variable X is determined by making a series of measurements of two independent variables Y and Z with variances 10 and 5 and mean values 100 and 50 respectively.

1. If $X = Y + Z$, then the variance of X is:

- A. 5
- B. 7.5
- *C. 15
- D. 75
- E. 125

2. If $X = Y - Z$, then the variance of X is:

- A. 5
- B. 7.5
- *C. 15
- D. 75
- E. 125

4

(1)

STUDY GUIDE
ABMP PART I

RADIOLOGICAL PHYSICS

UNITS: fundamental units
derived units
electrical units
radiation units

ATOMIC AND NUCLEAR STRUCTURE:

Bohr model elementary particles
shell structure nuclear structure
periodic table nuclear binding energy
electron binding energy mass energy equivalence
ionization and excitation

ELECTROMAGNETIC RADIATION:

frequency properties of non-ionizing radiation
energy lasers
wavelength microwaves
properties of ionizing radiation infrared

ULTRASOUND: speed in different media; properties

RADIOACTIVITY:

decay constant modes of decay:
half life alpha
mathematics of decay beta plus and beta minus
equilibrium EC
exposure rate constant internal conversion
dose rate near a isometric transition
point source nuclear reactions
isotope production
fission

PRODUCTION OF X RAYS:

basic X-ray circuit spectra
anode factors affecting spectra
cathode filtration
rectification quality
transformers HVL
Characteristic and angular distribution
Bremsstrahlung X rays versus energy

INTERACTION OF PHOTONS WITH MATTER:

attenuation Compton scatter
absorption pair production
scatter photonuclear
attenuation coefficients relative importance of different
photoelectric absorption interactions at different
coherent scatter energies and in different media

collisional
radiative
range

stopping power
LET
Bragg peak

NEUTRON INTERACTIONS:

elastic and inelastic

REFERENCES

Johns, H.E. and Cunningham, J.R. "The Physics of Radiology," 4th Ed., Thomas, Springfield 1983.

Khan, F.M. "The Physics of Radiation Therapy," Williams and Wilkins, Baltimore, 1984.

Hendee, W. R. "Medical Radiation Physics," 2nd Ed., Yearbook Med. Publ., Chicago, 1979.

Cameron, J.R. and Skofronik, J.G. "Medical Physics," Wiley, New York, 1978.

RADIATION DETECTION AND MEASUREMENT

DOSIMETRY FUNDAMENTALS:

exposure
 absorbed dose
 Kerma, detection
 (photons, neutrons)

IONIZATION CHAMBERS:

general principles
 and construction
 charge and current
 measurements

ion collection efficiency
 recombination
 saturation

IONIZATION INSTRUMENTATION:

personnel dosimeters
 survey meters
 thimble chambers

monitor chambers
 pancake chambers

DOSE MEASUREMENTS:

general Bragg-Gray theory
 principles
 stopping power ratio principles

DOSIMETERS:

photographic
 TLD
 semiconductors

basic principles of chemical and
 calorimetric dosimeters

DETECTORS:

GM
 proportional
 scintillation
 PM tubes

INTERNAL DOSIMETRY:

gamma and beta radiations
 effective half life
 mean life
 beta rays

REFERENCES

Johns and Cunningham. "The Physics of Radiology"

Hendee. "Medical Radiation Physics"

Cameron and Skofronik. "Medical Physics"

Attix, F.H. "Introduction to Radiological Physics and Radiation Dosimetry," Wiley, New York, 1986.

THE CELL: basic structure

CELL CYCLE: phases; cell cycle time

CHROMOSOMES: DNA; chromosome aberrations; mitosis

BASIC GENETICS: genes; genetic mutations

RADIATION CHEMISTRY: direct/indirect actions; free radicals; ions

CELL SURVIVAL CURVES: basic target and L-Q theories

DOSE RESPONSE: statistical nature of dose-response curves

ACUTE RADIATION SYNDROME:

hematopoietic
gastrointestinal
CNS syndrome

LD₅₀
latent period

RADIATION CATARACTOGENESIS:

ocular lens dose response
cataracts threshold

RADIATION EMBRYOLOGY:

human and animal data
effect of age
occupational exposures
patients

RISK VERSUS BENEFIT:

sources of human exposures
typical doses
relative risks

REFERENCES

Hall, E.J. "Radiobiology for the Radiologist," 3rd Ed.,
Lippincott, Philadelphia, 1988.

Johns and Cunningham. "The Physics of Radiology"

Webster, E.W. In: "Biological Risks of Medical Irradiations,"
(Ed. Fullerton et. al.), AAPM Monograph No. 5 AIP pp 55-57,
1980.

Gregg, E.C. Ibid. pp 160-176.

Bushong, S.C. and Archer, B.R. Ibid., pp 253-266.

Webster, E.W. et. al. "A Primer on Low-Level Ionizing Radiation
and its Biological Effects," AAPM Report No. 18. AIP, 1986.

RADIATION PROTECTION

UNITS: dose equivalent; Sievert; Quality factor

BEIR⁴ SOURCES OF HUMAN EXPOSURE: natural, medical and other sources

DOSE EQUIVALENT LIMITS: maximum permissible dose (MPD)
 philosophy of radiation
 radiation protection protection (ALARA)
 guides stochastic and non-stochastic
 occupational and non- considerations
 occupational exposures

RADIOACTIVE SOURCES: radionuclides
 storage
 transportation
 wipe testing

SURVEYS: basic methodology and instrumentation

PERSONNEL MONITORING: films
 TLD
 pocket dosimeters
 filters

EXTERNAL RADIATION PROTECTION:

NCRP⁴⁹ time basic protection design
 distance WUT
 shielding

INTERNAL RADIATION PROTECTION:

internal radiation contamination
 hazards waste management
 principles of control assessment of hazards

HAZARDS OF NON-IONIZING RADIATION:

lasers MR
 microwaves power and energy
 ultrasound biological effects

REFERENCES

Cember, H. "Introduction to Health Physics," 2nd Ed.,
 Pergamon, New York, 1983.

Turner, J.E. "Atoms, Radiation and Radiation Protection,"
 Pergamon, New York, 1986.

Khan, "The Physics of Radiation Therapy"

Bushong, S.C. "Radiologic Science for Technologists," 3rd Ed.,
 Mosby, St. Louis, 1984.

Johns and Cunningham, "The Physics of Radiology"

NCRP Report No. 91 and No. 93, NCRP, Bethesda, 1987.

SAMPLES, OBSERVATIONS: sample surveys; random sampling

FREQUENCY DISTRIBUTIONS: histograms
cumulative frequency
distributions
probability distributions

MEANS AND STANDARD DEVIATIONS:

arithmetic and	degrees of freedom
population means	mean values
standard deviations	median values
variance	modal values
coefficient of variation	

NORMAL (OR GAUSSIAN) DISTRIBUTIONS:

standard errors; confidence limits; sample sizes

TESTS OF HYPOTHESES: statistical significance
confidence intervals
chi-square test

BINOMIAL AND POISSON DISTRIBUTIONS:

relationship to normal distributions; propagation of errors;
applications

REGRESSION: linear regression; least squares estimates;
correlation coefficient

REFERENCES

- Snedecor, G.W. and Cochran, W.G. "Statistical Methods," 7th Ed., Iowa State Univ., Ames, Iowa, 1980.
- Millner, M., Waggener, R.G., and Pillai, B.K. "Statistical and Error Analysis in Medical Physics," Handbook of Medical Physics (Eds. Waggener, Kerieakes, and Shalek), CRC Press, Boca Raton, Vol. 1:69-92, 1982.
- Glantz, S.A. "Primer of Biostatistics," McGraw-Hill, New York, 2nd Ed., 1987.
- Evans, R.D. "The Atomic Nucleus," Reprint Edition, Krieger, Malabar, Florida, pp 746-818, 1985.
- Mould, R.F. "Cancer Statistics," Hilger, Bristol, 1983.
- Mould, R.F. "Introductory Medical Statistics," 2nd. Ed., Hilger, AIP, New York, 1989.

THE PHOTOGRAPHIC PROCESS: latent image production
 photographic emulsions and films
 film processing and chemistry
 electrostatic imaging -- Xerography

SENSITOMETRY:

Characteristic curves:

density	reciprocity failure
contrast	fog
latitude	reversal
gamma	solarization
energy dependence	effect of processing conditions
speed	

Resolution and Contrast:

modulation transfer function
 line spread function
 line pairs
 film contrast
 basic principles of MTF and LSF

Screens:

phosphors	resolution
modification of	mottle
H&D curves	effect on image quality and dose

Noise:

signal/noise ratio
 mottle-structured and statistical
 scatter
 grids

FLUOROSCOPY:

Basic principles of digital systems
 Basic principles of luminescence
 Image Intensification:
 design flux gain and minification
 brightness dose

RADIOGRAPHY: General imaging and equipment considerations

Basic principles of:
 angiography
 CT
 tomography
 mammography

IMAGE FORMATION: Subject contrast as related to density,
 atomic number, and energy spectrum

PHYSICS OF NUCLEAR MEDICINE:

Basic concepts:

applications	instrumentation and radionuclides
uptake	emission tomography
scanning	basic performance checks
cameras	hazards

Basic concepts:

NMR	instrumentation
relaxation times	applications
chemical shifts	hazards

PHYSICS OF CLINICAL ULTRASOUND:

Basic principles:	generation and detection
propagation	interactions in tissue
modes of operation	Doppler techniques
hazards	

REFERENCES

- Coulam, C.M., Erickson, J.J., Rollo, F.D., and James, A.E. "The Physical Basis of Medical Imaging," Appleton-Century-Crofts, New York, 1981.
- Haus, A.G. "The Physics of Medical Imaging," AIP, New York, 1979.
- Curry, T.S., Dowdey, J.E., and Murray, R.C. "Christensen's Introduction to the Physics of Diagnostic Radiology," 3rd Ed., Lea and Febiger, Philadelphia, 1984.
- Johns and Cunningham. "The Physics of Radiology"
- Sprawls, P. "Physical Principles of Medical Imaging," Aspen, 1987.
- Waggener, R.G., Kereiakes, J.G., and Shalek, R.J. "Handbook of Medical Physics, Vol. II," CRC Press, Boca Raton, 1984.

PRINCIPLES OF THERAPY

PHOTONS:

phantoms
percent depth dose
scatter

depth dose distribution
parameters affecting depth dose
isodose curves

PARTICLES:

Electrons: depth dose and isodose distributions
Heavy particles:
 protons
 pions

neutrons
stripped nuclei
Bragg peaks

BRACHYTHERAPY:

radioactive sources
sealed sources

activity
exposure rate constant
dose calculation principles

HYPERTHERMIA: basic principles of application and monitoring

REFERENCES

Johns and Cunningham. "The Physics of Radiology"

Khan. "The Physics of Radiation Therapy"

Kerieakes, J.F., Elson, H.R., and Born, C.G. "Radiation Oncology Physics -- 1986," AAPM Monograph No. 15, AIP, New York, 1987.

(8)

BASIC PRINCIPLES OF DC CIRCUITS:

potential difference	batteries
current	power
Ohm's law	series and parallel networks
resistance	Kirchoff's Laws
resistors	voltage dividers

BASIC PRINCIPLES OF AC CIRCUITS:

sinusoidal waveforms	inductive reactance
capacitors	RL circuits
capacitance	transformers
RC circuits	impedance matching
capacitative reactance	resonant circuits
rise and fall times	complex waveforms
inductors and inductance	Fourier analysis

MEASURING INSTRUMENTS:

moving-coil meters	Wheatstone bridge
moving-iron meters	AC bridges
dynamometers	potentiometers
AC and DC measurements	capacitance and inductance meters
RMS values	digital voltmeters and multimeters
practical application	electrometers
analog multimeters	

OSCILLOSCOPES:

basic principles and components
triggering
dual-beam and dual trace scopes
storage and sampling scopes

DIODES:

p-n junction	vacuum and semiconductor diodes
zener diodes	half-wave and full-wave
voltage doubler	rectification
RC filters	

TRANSISTORS:

bipolar junction transistor
field-effect transistor
applications

AMPLIFIER CIRCUITS:

basic principles and properties
types and applications

OP-AMPS:

properties
input and output impedance
gain
applications

DIGITAL BASICS:

basic principles
logic gates
gate construction
positive/negative logic

Boolean algebra
flip-flops
numbering systems
digital displays

DIGITAL CIRCUITRY:

counters and registers
D/A and A/D conversion
voltage-to-frequency conversion

NOISE:

origins
reduction techniques

GROUNDING AND SHIELDING:

principles and methods:
coax cables
isolation

grounding and shielding
RF shielding
guard shields

REFERENCES

- Diefenderfer, A.J. "Principles of Electronic Instrumentation,"
2nd Ed., Saunders, New York, 1979.
- Malmstadt, H.V., Enke, C.G., and Crouch, S.R. "Electronics and
Instrumentation for Scientists," Benjamin/Cummings, Menlo
Park, CA, 1981.

BASIC THEORY: metastable atomic states; stimulation

TYPES:

Nd-YAG
argon
krypton

He-Ne (alignment devices)
ruby
CO₂

USES:

retinal detachment
endobronchial
photocoagulation

surgery
dermatology
laser angioplasty

SAFETY:

types of injuries
standards
protection

REFERENCES

McKenzie, A.L. and Carruth, J.A.S. "Lasers in Surgery and Medicine," Phys. Med. Biol. 29:614-619, 1984.

Polanyi, T.G. "Physics of the Surgical Laser," Int. Adv. in Surg. Oncol. 1:205-215, 1978.

Carruth, J.A.S. and McKenzie, A.L. "Medical Lasers: Science and Clinical Practice," Hilger, AIP, New York, 1986.

Moseley, H. "Non-Ionizing Radiation." Medical Physics Handbooks 18, Hilger, AIP, New York, pp. 226-270, 1988.

ORGANIZATION OF THE HUMAN BODY:

anatomical nomenclature	body planes
anatomical position	body cavities
regional names	their subdivisions and contents
directional terms	

Levels of structural organization:

chemical, cellular, tissue, organ, system

PRINCIPAL SYSTEMS OF THE HUMAN BODY:

structure	principal methods of diagnosis
function	and therapy
pathology	medical terminology

Skeletal, Muscular, and Integumentary Systems:

skeletal tissue	muscle tissue
axial and appendicular skeletons	muscular system
articulations	skin and its derivatives

Nervous System:

nervous tissue	brain and its principal parts
the nerve impulse	sensory and motor systems
spinal cord and nerves	autonomic nervous system

Special Senses:

structure of outer, middle, and inner ear
 physiology of hearing and equilibrium
 structure of eyeball; visual physiology

Endocrine System:

endocrine glands - identity, location, function;
 other endocrine tissues
 mechanism of hormonal action

Cardiovascular System:

Blood:	
physical characteristics	hemostasis
functions	interstitial fluid and lymph
components	

The Heart:

pericardium	valves
wall	conduction system
chambers	cardiac cycle
vessels	cardiac output

Lymphatic System:

lymphatic vessels	non-specific resistance to disease
lymphatic tissue	reticuloendothelial system
immunity	

Respiratory System:

Organs:

nose	trachea
pharynx	bronchea
larynx	lungs

Respiration and its Control:

pulmonary ventilation air volumes and capacities
gas exchange and transport

Digestive System and Metabolism:

Digestive processes; characteristics of alimentary canal - wall structure, tube movements, enervation

Mouth: tongue, salivary glands, teeth

Pharynx and Esophagus: structure, deglutition

Stomach: parts, gastric secretions and absorption, mixing and emptying actions

Pancreas, Liver and Gallbladder

Small and Large Intestines

Metabolism: anabolism and catabolism, enzymes
carbohydrates, lipids and proteins
body heat and temperature regulation

Urinary System; Water, Electrolyte, Acid-Base Balance:

Kidneys: external and internal anatomy
blood and nerve supply
nephrons
urine formation

Elimination of urine: ureters, bladder, urethra

Body fluids: compartments, composition
movement, balance

Electrolyte and acid-base balance

Reproductive System; Development and Inheritance:

Male Reproductive System:

anatomy and physiology
spermatogenesis

Female Reproductive System:

anatomy and physiology
menstrual and ovarian cycles

The Breast: structure, function of mammary glands,
pathology

Pregnancy: fertilization and implantation
embryonic development
fetal growth and birth

Human Genetics:

chromosomes
dominant and recessive genes
meiosis

ANATOMICAL PRESENTATION BY IMAGING SYSTEMS:

Conventional radiographic anatomy.

Transverse and topographic anatomy.

Physical and chemical features affecting appearance in
images produced by:

X rays	radio pharmaceuticals
magnetic resonance	ultrasound

REFERENCES

- Tortora, G.J., and Anagnostakos, N.P. "Principles of Anatomy and Physiology," 5th Ed., Harper and Row, 1987.
- Hole, J.W. "Human Anatomy and Physiology," 4th Ed., Wm. C. Brown, 1987.
- Kapit, W., and Elson, L.M. "The Anatomy Coloring Book," Harper and Row, 1977.
- Hagen-Ansert, S.L. "The Anatomy Workbook - A Coloring Book of Human Regional and Sectional Anatomy," Lippincott, 1986.
- Novelline, R.A., and Squire, L.F. "Living Anatomy - A Working Atlas Using Computed Tomography, Magnetic Resonance, and Angiographic Images," Hanley & Belfus Inc., C.V. Mosby, 1987.
- Squire, L.F., and Novelline, R.A. "Fundamentals of Radiology," 4th Ed., Harvard University Press, 1988.
- Cameron and Skofronick. "Medical Physics."



FUNDAMENTAL CONCEPTS:

analog
digital
hardware
software

computer
peripheral devices
micro, mini, mainframe computers

HARDWARE: CPU:

capacity
speed
bus

Memory:

bits
bytes
RAM
ROM

Storage Devices:

floppy disks
hard disks
optical disks

Input Devices:

keyboards
mouse
trackball
joystick

light pen
digital pad
touch screen
voice

Printers:

laser
thermal
color
ink jet

SOFTWARE:

Operating Systems
Single User
Time Sharing
Batch Processing
Programming: basics

Languages:
Assembly
Fortran
C
Basic
Cobal
Pascal

APPLICATIONS:

nuclear medicine
diagnostic radiology
CT
MRI

ultrasound
therapy
PACs

REFERENCES

Vickery, B.L. "Computing Principles and Techniques," Medical Physics Handbooks 2, Adam Hilger, Boston, 1979.

**Sample Questions from ABMP Part I Exam
November 25, 1990**

Type 1 Questions: Fill in the blank

1. A modem for a radiology communications network operates at 300 Baud. How long would it take to transmit a CT scan if it uses 8 bits for a 512 by 512 image?
A. 10 seconds B. 60 seconds C. 10 minutes D. 2 hours

2. What is the desired therapeutic temperature range for hyperthermia?
A. 35 to 37 degrees Centigrade
B. 38 to 41
C. 42 to 45
D. 46 to 49
E. 50 to 52

3. An isotope has a half-life of 30 hours. A dose is calibrated by the manufacturer to be 10mCi at 12:00 noon. What is the activity of this sample at 9:00a.m. that same day?
A. 5.2mCi
B. 8.5
C. 9.0
D. 10.7
E. 12.0

4. Radium-226 has a half-life of 1622 years. How much radium-226 was there on the entire planet earth 1622 years ago?
A. Half as much as there is now.
B. The same amount as there is now.
C. Twice as much as there is now.
D. Can't answer from above information.

5. Assuming exponential survival, irradiation of cells with a single dose of radiation of 4 Gray reduces the number of survivors to 10%. What dose would reduce the number of survivors to 50%?

- A. 1.02Gy B. 1.80Gy C. 2.00Gy D. 3.5Gy E. 5.75Gy

Note: I could not get any of the above answers.

6. A cobalt-60 unit has a 2cm diameter source. What is the penumbra 10cm deep in a phantom at 80cm SSD if the collimators are 40cm from the surface of the phantom?

- A. 1.0cm
B. 1.5cm
C. 2.0cm
D. 2.5cm
E. 3.0cm

7. What is one Joule per Coulomb?

- A. 1 eV
B. 1 erg
C. 1 volt
D. 1 watt
E. 1 Gray

8. How many bones are there in the following regions of the spine: cervical, lumbar, thoracic?

- A. 5, 7, 12
B. 12, 7, 5
C. 5, 12, 7
D. 7, 5, 12

9. A 10Ci source is located in the center of a shielded container. The container is 20cm in outer diameter and has walls 5cm thick. If the isotope produces an exposure rate of 5.0 R/hour at 1cm per mCi, and the walls of the container have a half-value layer of 0.5cm, what is the exposure rate at the outside surface of the container?

- A. 0.1 mR/hr
B. 0.25
C. 0.5
D. 1.0
E. 5.0

There also were a couple of questions on variance of sums and differences of related measured quantities.

Type 2 Questions: Matching

There are five possible answers to each question. Each may be used more than once, or not at all. Four questions are then posed, and these choices are the possible answers.

- A. Thimble chamber
- B. Geiger counter
- C. Sodium iodide well counter
- D. Gas flow proportional counter
- E. Photomultiplier

What is the most appropriate instrument to measure the following?:

1. Alpha particle measurement
2. Gamma emitting leak-test sample
3. Calibration of a linear accelerator
4. Check for gamma contamination on your body

- A. 14 mrem
- B. 39 mrem
- C. 100 mrem
- D. 200 mrem
- E. 2400 mrem

What does BEIR V give as annual dose equivalent to the general population from each of the following?

5. Radon exposure
6. Diagnostic radiology exams
7. Nuclear medicine exams
8. Other terrestrial exposures

- A. 0.05 Sv/year
- B. 0.15 Sv/year
- C. 0.30 Sv/year
- D. 0.75 Sv/year
- E. 1.00 Sv/year

What does the NCRP 91 recommend as the annual dose equivalent limit for occupationally exposed workers?

- 9. Feet and ankles
- 10. Whole body
- 11. Thyroid gland
- 12. Other organs

- A. 2mR
- B. 20mR
- C. 200mR
- D. 2000mR
- E. 20,000mR

What is the typical exposure from the following examinations?

- 13. CT brain scan
- 14. Mid-plane exposure of breast
- 15. Chest X-ray
- 16. One minute of a GI fluoro exam

You are given a photocopy of a CT scan thru the pelvis with points labelled A, B, C, D and E. Please identify the following:

- 17. Femoral head
- 18. Pubis symphysis
- 19. Bladder
- 20. Rectum

Type 3 Questions: Multiple Answer True-False

These questions consist of four statements about one topic, each of which is considered to be either true or false. Your answer is one of the following foils:

- A. All four statements are true.
- B. Statements 1, 2 and 3 are true.
- C. Statements 1 and 3 are true.
- D. Statements 2 and 4 are true.
- E. Only Statement 4 is true.

1. Which of the following are medical uses of laser?

- 1. Holography
- 2. Photocoagulation
- 3. Photodynamic therapy
- 4. Cryogenic surgery

Note: I questioned this question's accuracy.

2. What information do you need to calculate a primary shielding barrier?

- 1. Output per hour at 1m
- 2. Distance to wall
- 3. Fraction of time beam directed at wall
- 4. Composition of wall

3. The Polarization Effect in stopping power theory:

- 1. Is also known as the density effect
- 2. Depends on atomic number
- 3. Is proportional to particle velocity
- 4. Is proportional to the particle charge

4. Which of the following lasers are used for surgery?

1. YAG
2. CO₂
3. Argon
4. HeNe

1991 General Exam - 392 questions, 4 hours

At which temperature do Celsius and Fahrenheit scales give equal readings?

If a person intakes 20 picoCuries of Cs-137, with an effective half-life of 20 years, compute the cumulative activity.

True/False: Momentum is conserved in inelastic collisions.
Momentum is conserved in elastic collisions.
Energy is conserved in inelastic collisions.
Energy is conserved in elastic collisions.

Express the units of gravitational constant G in mass, distance, time.

Given an RC circuit, calculate the time constant.

Given the kinetic energy of an electron, compute its velocity.

If the radius of the first electron orbit of an atom is n , what is the radius of the second orbit.

Transformer problem: V is 240 volts (RMS), kVp is 96 kVp, compute the ratio of I_2/I_1 .

If an electron travels at $0.8c$, what is the required index of refraction in a medium such that Cerenkov radiation is produced.

A radiopharmaceutical dose of Tc-99m is delivered at 8 AM. The desired dose is 15 mCi at noon of the same day. What is the activity at the time the dose was delivered?

True/False: The organs in the abdomen include: stomach, liver, spleen, hypophysis, thymus.

True/False: Structures in the mediastinum include: trachea, esophagus, heart, ureter.

Does a patient who receives an I-125 therapeutic implant require a private room?

Calculate joules for a single phase unit, given kVp and mAs.

Given a water phantom which is 20 cm thick with a HVL of 10 cm water. If the SSD is 50 cm, calculate the ratio of the exposure at the bottom of the phantom to the exposure at the top.

Calculate rads required to heat water by 1 degree Celsius. Mass or volume of water not given.

What type of detector should be used for:

- surveys in a laboratory that uses C-14 and H-3
- finding a lost Cs-137 needle
- daily contamination checks in a Nuclear Medicine dept.

Compute bytes needed for a 256 x 256 image, 16 frames, 256 shades of gray.

True/False: Acoustical impedance depends on: temperature, Z of material, density, etc.

Calculate output in mR/mAs at 70 kVp if given output in mR/mAs at 100 kVp. Same type of problem for variation in mAs and distance.

Doppler effect - calculate percent change in frequency given soft tissue, initial frequency, 45 degree angle, speed of flowing blood.

NCRP-91 dose limits.

Calculate linear attenuation coefficient for a compound, given linear attenuation coefficients of each of the elements and the weight fractions.

Types of cancer - where they originate.

Children of Atomic Bomb Survivors - what effects have been seen.

Blood flow - trace blood from heart to lungs to aorta. Know vessels and valves.

Process by which oxygen is exchanged in the lungs; is it osmosis, diffusion, or active transport.

Match hormones with glands in which they are secreted.

Calculate linear attenuation coefficient for a tissue given CT number and the linear atten. coeff. for water at the same energy.

Calculate flux density and energy density for a 1 mCi Co-60 source at 5 cm.

1991 ABR Nuclear Medical Physics Exam

Calculate true count rate R for a paralyzable detector given the observed count rate and a dead time of 6 microseconds.

Given two sources with observed count rates for R_1 , R_2 , R_{12} and background, calculate the dead time.

Calculate probability P for a Poisson distribution.

Given 20 count measurements, determine how likely the distribution is to be a Poisson distribution (90% chance, 70%, 50%, 20%, etc.)

What is the number of counts required to achieve a 1.0% error at the 95% confidence level?

Many detailed 10 point problems on calculating uptakes in Schillings tests (using both Co-57 and Co-58), thyroid uptake tests, cardiac output in gated cardiac studies, Cr-51 blood cell labelling (total blood volume, plasma volume, red blood cell mass).

Calculate geometric resolution and efficiency for a pinhole collimator. No calculations for parallel hole collimators.

Xenon gas problems - given 4 patients per week, 20 mCi per patient, 5% loss, volume of room. Calculate exhaust rate from room to maintain concentration at MPC. Need to have MPC memorized.

Xenon gas problem variation - given air flow rate, room volume, and activity per patient, calculate evacuation time for the room if a spill occurs.

Trivial MIRD dose calculations - calculate cumulated activity if given A_0 , T_{eff} . Given a decay chart and absorbed fractions, do some easy MIRD calculations.

Calculate geometric efficiency for a 1 inch diameter detector at 1 meter from a point source.

Given a radioisotope which decays with gammas at specified energies, which peaks are possible on a PHA spectrum (included single and double escape peaks).

Describe effects on a pulse height spectrum if window width is changed, amplifier gain increased or decreased, upper discriminator removed, etc.

ABR THERAPY PHYSICS WRITTEN EXAM - OCTOBER 4, 1991

SAN FRANCISCO, CALIFORNIA

TOPICS

Water-equivalent path length calculations

Isodose shift calculations for sloping surfaces

What is the correct physical set-up when measuring TPR?

A problem involving segments of an SAR

Neutron contamination: how do you measure it and how do you eliminate it?

GM counters vs ionization chambers

If you puncture your GM counter, is it a problem?

How is skin dose affected by the addition of a lucite tray?

A radian calculation

Hyperthermia questions: does the probe conduct electricity? Is it primarily the circulation of the blood that removes the heat from the treated area? Is the ultrasound wave reflected by a gaseous bubble?

What is the wavelength of the microwaves in a linear accelerator?

What does a linac's thyratron regulate?

90° vs 270° bending magnet questions

A gap calculation for fields having different SSD's (80 cm and 100 cm)

Is the monitoring chamber of a linac placed between the primary collimator and the scattering foil?

Cerrobend questions: is there lead in cerrobend? Does this pose a personnel health risk? How thick should cerrobend blocks be?

Calculate the dose to a point from a cesium brachytherapy source using the along and away tables.

Given 15 MeV electron beam with an $R_p=7.5$ cm, what is the energy of the beam at 6 cm depth? [Answer: $15(1-(6/7.5))=3$ MeV]

What are the units of N_{gas} ? [Gy/c or Gy/scale division]

Calibration of electrons in plastic according to TG-21

NCRP Report #102

Treatment planning problems: Given a circular patient treated by three beams separated by 120°. If you add a 15° wedge (heel left) to the AP beam, which way should you rotate that beam to keep the distribution homogeneous? 15° clockwise, 30° clockwise, 0°, 15° counterclockwise, or 30° counterclockwise?

JCAHO regulations regarding the credentials of the radiation oncologist, the radiation physicist, and the technologists when purchasing a Co-60 unit

Treatment planning problem: A patient is treated with three fields, one open AP and two laterals with 70% transmission. The AP is normalized to 100% and the wedged laterals are normalized to 70% at d_{max} . The combined isodose in the treatment area is 135%. If you desire to give 180 cGy to that isodose, what is the given dose of the unwedged AP?

Treatment planning problem: A patient is treated with parallel opposed laterals which give 60 cGy in two beams of 147 MU each. Those MU's were found, after 10 treatments, to be 20% low. How much should you increase the MU's by so that the final dose will be the same at the end of the next 20 treatments?

Neutron contamination: how do you measure it and how do you eliminate

ABMP August 1992 PART I
Praveen Dalmia

Some of the questions below are identified by type, i.e. A, B, K, or S. The answers given, if any, are incomplete and, in the case of type K, do not follow the correct order. Not all answers/questions are accurate, but they follow the general outline of what was asked in the exam. Also, types A, B, and S shown below have been mixed due to memory lapses and have been classified together as one category (A). This does not make much of a difference, since while taking the exam, one can only differentiate between two types of questions: (A, B, S) and (K).

- A: Five choices, choose correct answer.
- B: Match items - items to match can be used multiple times.
- K: a,b,c,d, or e (see below)
- S: Some data given followed by 2-5 questions.

The exam consisted of approx. 150 questions. The first 90 questions or so were of types A, B and S. The rest (latter 1/3rd) were of type K.

Type K questions had four properties (1, 2, 3, 4) of the phenomenon/topic being questioned listed. This was followed by the following five choices (A-E):

- a. 1, 2, 3 only
- b. 1, 3 only
- c. 2, 4 only
- d. 4 only
- e. All are correct

HINT: From these choices, one can reason that:

If 1 and 4 are true, then all are true

If 2 and 3 are true, then 1 is true

If 1 is true, then 3 is true

If 2 is true, then either 3 or 4 is true.

If 3 and 4 are true, then all are true

Note: The above argument applies to all type K questions.
ONLY SI UNITS WERE USED (eg. Sv, mSv, cGy)

1. (A) Joule/Coulomb = ?
answer: volt.
2. (A) What is the maximum energy that should be considered for shielding a 6 MeV x-ray scattered at 90 degrees?
answer: Maximum energy for any backscattered x-ray is 511 keV.
3. (A) What is the time required to transmit a 512 x 512, 8-bit image via modem operating at 300 baud?
answer: 2 hours
4. (A) A CT slice (256 x 256) is stored in a computer as _____?
answers: an 8 bit address a matrix, a 256 x 256 matrix,
5. (A) According to NCRP # 91, the annual radiation worker whole body dose limit is _____.
answer: 50 mSv. *50 Rem*
6. (A) According to NCRP # 91, the annual radiation worker dose to the lens of the eye is _____.
answer: 150 mSv. *15 Rem*
7. (A) The maximum dose that a pregnant worker can receive per month is _____ mSv.
answer: 50 mrem, *5 mSv*
8. (A) GSD is....
answer: the dose received by gonads averaged over # of progeny
9. (A) The mass of a 5 MeV electron compared to rest mass of an electron is _____
answer: m_0 , $9m_0$, $10m_0$, $11m_0$
10. (A) The mass of an electron traveling at 0.99 times the speed of light is _____
11. (K) Medical use of lasers includes
 1. photocoagulation
 2. cytometry
 3. holography
12. (K) Protective eyewear is used in lasers because:
 1. the wavelength is s.t. it'll damage the cornea;
 2. the wavelength is s.t. it'll damage the retina;
 3. the intensity of the beam will damage the eye.
13. (K) MRI is not harmful because:
 1. no harmful effects have been shown
 - 2 it doesn't use EM radiation.
 3. Because MRIs don't affect pacemakers

14. (A) The velocity of ultrasound.....
answer: decreases/increases with density of the medium, decreases/increases with frequency of wave

15. (K) Velocity of ultrasound
1. decreases with compressibility
2. greater in fat than in muscle

16. The strength of MRI magnet is typically.....
answer: 1 Tesla

(B) For questions 17-20, five figures showing a beam in air or in medium were drawn. The distances (SAD, SSD, d, d_{max}) were shown. Four choices were given (eg. Fig 1/fig 2, fig 4/fig3, fig1/fig 4).

One was then asked which of these choices was a definition of:

17. PDD
18. BSF
19. TMR
20. f factor

21. (K) When going from a thicker patient to a thinner patient while doing fluoroscopy using auto brightness control:
1. kVp and/or mA decrease decreases
2. mA decreases, kVp increases
3. gain of picture tube increases
4. kVp decrease, mA increases.

22. (K) A transporter gets 1000 mR to his/her badge. This is possibly due to:
1. The transporter wore the badge for a chest x-ray.
2. He left his badge in his car.
3. He transported an excessive number of I-125 patients.
4.

23. (A) A patient was treated on Jan. 1, 1991 at 113 SSD. On June 30, 1992, the output of the unit at 80 cm SSD, 0.5 cm depth is 100 cGy/min. what was the dose to the patient at 0.5 cm depth if the treatment time was 2.36 min and there was no timer error?

24. (A) Timer error problem:
A 5 second exposure rate = X (X was an actual number given)
A 30 second exposure rate = Y (Y was an actual number given)
The exposure for 60 s will measure _____.

(B) Match the following with questions 25-28:

A. operating system
B. language
C. compiler
D.
E.
25. Unix
26. C

27. Fortran
28.
29. (A) A compiler is used to.....
answer: convert high level language into assembler code.
30. (A) During beta minus decay the proton number (Z):
answer: +1, +2, -1, -2, unchanged
31. (A) Electron capture (EC) is a competing process with...
answer: beta positive decay
32. (A) To improve Signal/Noise ratio in PET.....
answer: use coincidence circuitry.
33. (A) SPECT uses.....
answer: Multiple images at different angles.
34. (A) Which of the following can be used for energy discrimination analysis?
answer: NaI and Ge, GM counter, ionization chamber
- (A) Given a CT image thru a chest, one was asked to identify:
35. Aorta
36. Superior Vena Cava
37. Spine
38. Oesophagus
- (A) Given an AP image, one was asked to identify:
39. Ischium
40. Sternum
41. Clavicle
42. Ilium
43. (K) While irradiating the thoracic esophagus, which organs maybe in the beam?
1. lung
2. spinal cord
3.
4. pineal body
- (B) For questions 44 - 47 match the origin of the following cancers.
answers to choose from:
a.) skin
b.) fat
c.) bone
d.) blood vessels
44. Liposarcoma
45. Basal cell carcinoma
46. Osteosarcoma
47. Angiomyolipoma

(B) For questions 48 - 52: During a nuclear accident 1000 people get a whole body dose of 300 cGy each.

Answers to choose from:

- a.) 3 days
- b.) 30 days ✓
- c.) 60 days
- d.) 2 years
- e.) 10 years

- 48. The maximum death rate will be seen at _____
- 49. All blood platelet restored by _____
- 50. Greatest incidence of leukemia will be seen after _____
- 51. Increased incidence of solid tumors will be seen after _____

52. (A) A dose calibrator uses
answers: NaI x-tal, ionization chamber, liquid scintillation detector, GM counter

53. (A) Leukopenia is
answers: increase/decrease in number of leukocytes, increase/decrease in number of lymphocytes

54. (A) A patient was administered I-131 on Monday. The thyroid uptake was measured on Wednesday, along with a reference source. The followup Wednesday, the uptake was 70% of that of the reference source. What was the $T_{eff1/2}$.

55. (A) Under adiabatic conditions, 0.2 A current is allowed to flow through an 8 ohm resistance imbedded in a 30 g mass of tissue for 10 s. The temperature rise measured is 0.2°C. What is the dose required for this temperature rise?
answer: Use the equation: $[(I^2 \times R) \times t] / m$

56. (K) Which of the following are electrical transducers?
1. thermocouple
2. photovoltaic cell
3. photomultiplier tube (PMT)
4.

(B) Use the choices given for questions 57-60.

- 57. Thermistor A. Used at high temperatures.
- 58. Thermocouple B. junction of 2 different elements.
- 59. Thermometer C. made of platinum wire.
- 60. D. made of tissue equivalent material

61. (A) Radionuclides produced by bombardment of neutrons decay by?
answer: Beta minus

62. (A) Photodisintegration starts at _____ MeV?

63. (A) At 15 MV the predominant photon interaction is via _____.
answer: Compton scatter.

64. (A) Polarization effect is also known as _____.
answer: Density effect.
(Question was a repeat from a previous ABMP exam)
65. (A) The units of Linear energy transfer (LET) is:
answer: Joule/meter!!
66. (A) Kerma is _____.
67. How many HVLs are required to decrease the exposure to 1/32 of its initial value? (The question was based on a given exposure rate at a nurses station from a brachytherapy patient. The required exposure level was also given. One was asked to calculate the number of HVLs to reduce the exposure to the required level.)
answer: $(1/2)^n = 1/32$ $n = 5$
68. (A) A 10 Ci Cs-137 source is kept in a lead container with a diameter of 20 cm. HVL = 0.5 cm. What is the dose rate at the surface of the container? 2.9×10^{-10} R/hr
 2.9×10^{-10} mR/hr
69. (K) Dose rate at a point 1 m from a radioactive source can be reduced to 1/4 by:
answers: double the distance, add 2 HVLs in between, add 1 HVL and increase distance by 1.4 meter, reduce activity to 1/4th
- (B) Match questions 70-71 (actually there were 4 questions) with the following types of interactions:
- A. beta-
 - B. beta+
 - C. alpha
 - D. gamma
 - E. electron capture
70. Isomeric transition:
71. Z increases by 1
- ✗ 72. (A) When the mean = 10, the std. dev. = 50. If we were to add 500 to the mean, the new mean will be
answer: 510 ± 50 .
- ✗ 73. (A) Instrument calibration has a 0.17% error with a 95% confidence level. The error in the measurement is 0.15%. What is the total error?
74. (A) Given $P_1 = 760$, $T_1 = 0^\circ\text{C}$, $P_2 = 750$, $T_2 = 22^\circ\text{C}$ Density correction for $P_2T_2 = ?$.
- ✗ 75. (A) The reflected intensity of an ultrasound wave is 50 dB less than the incident wave. If $I_0 = 10^7$ W/cm². What is the intensity of the reflected wave?
- ✗ 76. (A) Two films transmit 10 and 15 units respectively. If optical density of 1st film is 1, what is the optical density of 2nd film?
answer: 0.87
- ✗ 77. (A) Given $N = 1$; $D_0 = 0.464$. If dose given = 1.2 Gy, what is the survival level?

- ✗ 78. (A) What is the annual dose to person in the US from background including radon?
79. (A) What is the temperature for hyperthermia?
answer: 42°C.
- ✗ 80. (K) MRI measures:
1. proton density
2. proton-lattice
3. proton-proton
4. electron density
- ✗ 81. (A) what is the annual exposure from medical examinations.
- ✗ 82. (A) Given an equation, integrate from 0 to infinity
 $A = A_0 [e^{-0.05t} - e^{-0.2t}]$ $A_0 = 100$
answer: 1600
(The problem was presented differently, but this was the crux of the question).
83. (K) Gamma depends upon
1. energy of gamma ray
2. number of gammas emitted.
84. (K) Radioactivity is distributed evenly in an organ; dose to another organ depends upon:
1. size of organ
2. Energy of gamma
3. Distance between the organs
85. (A) For equal weight, the photoelectric effect in lead is _____ times that in water for a 80 keV photon.
answer: 1000, 100, 10, 1, 0.1
- ✗ 86. (K) Collection efficiency of detector (P_{ion}) will increase with:
1. decrease in distance between electrodes
2. decrease of bias voltage
3. increase in dose rate
87. (K) GM counters will:
1) Read zero in very high fields.
2) Quenching gas is used to reduce multiple pulses.
3)
- ✗ 88. (A) What connects DNA strands?
answers: purines, C-H bonds, H-H bonds
89. (A) Wedges are used in Radiation Therapy for:
answers: reducing heel effect; sloping surface; good isodose distribution
90. (A) Question on neutron detectors.

- ✕ 91. (A) Question on TLD activator centers.
- ✕ 92. (A) TLD glow curve peak depends upon
answer: temperature of readout and substance.
93. (A) Law of Thirabodine and Begonie states that:
answer: the radiosensitivity of a cell is inversely proportional to its differentiation.
- ✕ 94. (A) Tritiated thymidine is used to study cell cycle via:
answer: cytometry, autoradiology, electron microscope
95. (A) Plating efficiency = 70%; number of cells seeded = 1000. Number of colonies counted = 18. What is the surviving fraction?
- ✕ 96. (A) Doubling dose is
97. (A) Increase in time of film development _____
will increase film gradient
98. (A) Typical dose to breast in a mammogram?
99. (A) Stopping power (2 questions on definition)
100. (A) Find penumbra of Co unit at $d = 10$ cm given $SSD = 80$ cm; $SCD = 40$ cm; 1.0 Ci source.
answer: 1.5 cm
101. (A) Given $SID = 100$ cm; patient thickness = 20 cm; $HVL = 4$ cm of patient. Exposure on film = 5 mR. Entrance exposure to patient = ?
102. (A) A circuit of resistances in series where each resistor has a partial voltage drop across it is called?
answer: Wheatstone bridge. Potential divider.
103. (A) Outer wire of a coaxial cable should be
answers: grounded; same V at inside of cable; should be an insulator
- ✕ 104. (A) A transformer losses energy due to:
answer: dielectric; eddy; resistance of wire
- ✕ 105. (A) Energy loss due to eddy currents in a transformer can be reduced by:
answer: using laminated sheets in the core.
- ✕ 106. (K) Quantum mottle is reduced by:
1. increasing kVp
2. using rare earth screens
3. is not important in fluoroscopy
107. (A) Digital imaging results in:
answer: reduced quantum mottle;

108. (A) Energy loss by electrons in a nucleus' field is called
answer: Bremsstrahlung
109. (A) Plank's constant relates:
answer: energy and freq.
110. (A) Ionization energy is the energy to
answer: remove the electron from the atom; maximum energy of the characteristic radiation
111. (A) Bragg peak is due to _____
answer: the deposition of energy at end of path of heavy particles.
112. (A) With a 6 MV photon beam, the damage in cell is caused by
answer: neutrons, photon, electrons,.....
113. (A) A 15 MV beam is preferred over a 4 MV beam for pelvic treatments because:
answer: less penumbra; less normal tissue dose
- ✎ 114. (A) A person has two primary cancers, breast and brain. Survival level is 16% for brain, 6% for breast. What is the person's expected survival level?
- ✎ 115. (K) Sensitivity of condenser chamber can be increased by: Answer: increase volume; increase capacitance
116. (A) 80% of the body weight is made up of:
answer: carbon, oxygen, hydrogen
carbon, calcium, hydrogen
- ✎ 117. (A) Photons lose energy by:
answer: inelastic collisions with electrons; elastic collisions with electrons
118. (A) Energy lost in coherent scattering is of the order of
answer:
- ✎ 119. (K) Energy carried off by a compton scattered electron:
1. depends upon angle of scatter of electron
2. is a max of $(E_{\text{photon}} - 255) \text{ MeV}$
3.
- ✎ 120. (K) A person gets nearly LD_{50} of whole body radiation. Symtoms within hours of dose include:
1. convulsive siezures
2. loss of hair
3. diarrhea
121. (K) Which of these are involuntary actions?
1. Diastole
2. Systole
3. Peristalsis

122. (A) Question on time axis/sweep generator synchronization in an oscilloscope.
- * 123. (A) The plane dividing the body into anterior and posterior is answer:
sagittal/coronal/transverse/
124. (A) A cathode is made of tungsten because:
answer: it has a high melting pt.

ABMP August 1992 PART II (Therapy)
Praveen Dalmia

The pattern of questions in this exam was similar to part I. However, nearly 50% of the 150 questions were of type K. Prepare to spend 75% of your time answering the K type questions.

1. (A) Beam current before the target for photon beam is ____ times that for an electron beam.
answer: 1000, 100, 0.1, 0.01
2. (A) 5 mm of beam attenuates 100 photons from a beam that initially had 1000 photon.
How many photons will the next 1 cm attenuate?
3. (A) The maximum photon energy to be considered for 6 MV photon scatter at 90 degrees?
(This question was both in parts I and II)
4. (A) The penumbra in Co-60 units is more than in linac because:
- ✗ 5. (A) Six ^{137}Cs sources form a Patterson-Parker circle; diameter of the circle is 2 cm.
What is the dose at 1 cm from center of the circle. (Question was asked in 1991 exam also)
- ✗ 6. (A) Calculate the thickness of concrete (HVL = 4.6 cm) needed for shielding a nurses station that is 10 feet from HDR room. Dose per week delivered (i.e. workload) = 4000 cGy at 1 cm; Nurses are restricted to 0.1 mSv/wk.

(B) What'll you use to measure:
 7. Timer error
 8. Electron beam energy
 9. Surface dose on a patient
 10. Dose distribution in an arc therapy
 - 11.
12. (A) Typical kVp for a lateral pelvis film in simulator is:
13. (K) The use of cassette in MV beam (port) films:
 1. reduces MUs
 2. Gives better resolution in MV beam than diagnostic range.
- ✗ 14. (B) Match doses for the following diseases: prostate; post-op breast; seminoma; (these were four individual questions)
- ✗ 15. Question on total body skin electron therapy
16. (K) In total body given photon therapy:
 1. Lead/cerrobend blocks used to shield lungs
 2. compensator used to reduce dose to head
 - 3.
17. (A) The energy of photon at the door of a linac room after 2 reflections = _____. Initial energy = 6 MV.
answer: 0.511 MeV, 2.02 MeV, 1.6 MeV

18. (K) Which of these can be used for tumor localization of the head:
1. MRI
2. CT
3. SPECT
4. Angiography
19. (K) The anatomical structures that are irradiated during therapy of the uterus include.....
20. (A) There is a 5 cm error in the setup in SSD of 100 cm; Error in PDD at 10 cm depth for 6 MV beam will be
(It did not state if the error was +ve or -ve. The answers were in %age)
21. (A) What should one use to measure profiles quickly for 3 x 3 field for stereotactic surgery?
answer: film, TLD, ion chamber
22. (A) Before an intraoperative procedure (IORT)
answers:
A. The treatment plan is made
B. The physician is provided calculations and dosimetry
C. The patient is simulated
D. TLDs are used to measure dose delivered during IORT
E. The dose is delivered in single fraction
23. (A) For a 3 x 3 electron field compared with a 10 x 10 field
answers:
A. The R_p remains the same
B. The R_{50} decreases (or changes)
C. The surface dose changes
D. The output changes
E. The depth of max dose changes
24. (A) The NRC requires that output for one set of operating conditions be measured
answer: monthly.
25. (A) The NRC requires the chamber used for annual calibrations be calibrated by
answers:
A. An ADCL annually
B. An ADCL every 5 years
C. An ADCL every two years
D. Compared with a local standard
E.
26. (K) The question tested all methods of matching head and neck/scv fields.
27. (K) In electron arc therapy the
1. d_{max} decreases
2. PDD decreases
3. R_p remains the same
4. Photon contamination increases

28. (A) Two lateral marks are put on a pelvis and a lateral simulation film taken. What do you need to measure size of actual tumor on the film. (various options were provided)
29. (K) Brachytherapy sources should be loaded
1. By a different person each time
 2. Using long tweezers
 3. Behind a Pb shield
30. (A) Afterloading sources for brachytherapy should be stated in answer: mg. equivalents of radium; activity;
- (B) What produces the following dose distributions:
- | | |
|-------------|----------------------------|
| 31. Box | a) 60° wedges, 110° hinges |
| 32. Diamond | b) 30° wedges, 50° hinge |
| 33. ellipse | c) bilateral 120° arcs |
| 34. | d) AP/PA, R/L lat box |
| | e) AP, R/L post obliques |
35. (A) For a 40° wedge, the hinge angle is answer:
36. (K) AP/PA separation is 20 cm; R/L lateral separation is 38 cm; the dose ratio for a box technique for AP/PA v/s R/L lateral
1. 1/1, 1.5/1.5
 2. 1/1, 2/2
 3. 1.5/1.5, 1/1
 4. 2/2, 1/1
- (B) Use the following choices for questions 37-40.
A. 1/4 B. 1 C. 1/8 D. 1/16 E. 1/2
37. Primary wall use factor
38. Secondary wall use factor
39. Occupancy factor for nurses station
40. Occupancy factor for walkway outside room
41. (K) For which of these must one shield against in a linac room's door?
1. Fast neutron
 2. Slow neutron
 3. scattered x-rays and characteristic x-rays
 4. Gamma rays
42. (K) What must one test after an HDR source change?
1. dwell time
 2. timer error
 3. travel time
 - 4.
43. (A) D_{80} for a 15 MeV electron beam is answer: 5 cm

44. (K) D_{max} of a high energy beam changes with
1. SSD
2. field size
45. (A) What is use in intraoperative electron therapy to block other organs?
answers: cerrobend/thin Pb strips/superflab/beeswax/lucite
- ✗ 46. (K) Stereotactic radiotherapy currently consists of:
1. multiple stationary ports
2. single or multiple arcs
3. multiple stationary ports and arcs
4. simultaneous couch motion with multiple ports
47. (A) One morning the beam flatness is found off in the cross plane direction and the cGy/MU is high. The probable cause is answer: flattening filter shifted by 1 cm.
48. (A) The geometric and physical isocenter of a linac are off by 5 mm; This could be due to.....
answer: gantry sag/collimator uncentered/ gantry bearing weak/ x-hair uncentered
- ✗ 49. (A) What controls the dose rate in a linac?
50. (K) Magnetron in a linac is changed. What does one need to check before using the linac clinically?
answer: cGy/MU
51. (A) A 10 MeV electron beam is used to treat the lung of a patient. The lung starts 3 cm from the surface; lung electron density = 0.5 that of tissue. The effective R_p of the electron is.....
52. (K) A simulator
1. Adds treatment machine's motions with diagnostic filming capability
2. must have fluoro
- ✗ 53. (A) Difference between SCRAD and N_{gas} method is
A. Bragg gravity is used in SCRAD and not N_{gas}
B. SCRAD dose not account for physical characteristics of chamber wall
54. (A) What'll you use to measure dose distribution for a dynamic wedge rotation?
answer: TLD, film, ionization chamber
55. (K) In rotational (arc) therapy
1. The MU/cGy remains constant
2. The MUs/degree remains constant

ABR October 1992 Part I
Praveen Dalmia

EXAMINATION FORMAT:

The format of the examination was changed from this year. The anatomy/physiology examination was separate from the physics examination. The physics examination had 160 questions and one had 3 hours to answer them. The anatomy/physiology section had 60 questions and one had 1 hour to answer them. The 3-hour physics test was administered and the test books taken back before the anatomy/physiology section was given out. The physics part was long and many people ran out of time without completing the test. For the anatomy section, however, one needed only 15-20 minutes. **FINAL VERSION OF PART I WILL BE AVAILABLE MARCH END**

PHYSICS SECTION:

The examination was multiple choice, consisting of 160 questions. Questions 1-30 were 5 point questions with five choices each and required minimal calculations; 31-60 were 10 point questions, again with 5 choices each, but required more calculations. Also, questions 31-60 were sometimes grouped together -- eg. sometimes the same data was used for 5 questions; 61-100 were true/false questions of 2 points each. The T/F questions were lumped in sets of 5 questions, each set dealing with one specific topic. Thus these last 100 questions dealt with 20 separate topics and required no calculations. **(PART II of the examination, i.e. therapy physics/diagnostic/nuclear, also followed the same pattern as this part of the examination)**

1. Energy of electrons decreases monotonically with depth in a phantom. (T/F)
2. Molecular motion produces radiation in the UV range. (T/F)
3. Given atomic number of 2 different material, the efficiency of bremsstrahlung will be greater for which one. (5 pt. question)
4. TLD glow curve will be decided by preannealing method before irradiation. (T/F)
5. Pair production in an electron field is called triplet production. (T/F)
6. RBE the ratio of (T/F)
7. Dosages of radiopharmaceuticals must be dispensed under a fume hood according to the NRC. (T/F)
8. What contributes to the population dose? (5 points)
 - 1) P-40
 - 2) x-ray exposure
 - 3) Rn
 - 4) C-14
9. A 32-bit computer is one with a (5 points)
 1. 32 bit bus
 2. 32 bits in the memory
 3. 16 bit bus
10. The x-ray in electron capture comes from the parent (T/F)

ABR October 1992 Part I
Praveen Dalmia

EXAMINATION FORMAT:

The format of the examination was changed from this year. The anatomy/physiology examination was separate from the physics examination. The physics examination had 160 questions and one had 3 hours to answer them. The anatomy/physiology section had 60 questions and one had 1 hour to answer them. The 3-hour physics test was administered and the test books taken back before the anatomy/physiology section was given out. The physics part was long and many people ran out of time without completing the test. For the anatomy section, however, one needed only 15-20 minutes. **FINAL VERSION OF PART I WILL BE AVAILABLE MARCH END**

PHYSICS SECTION:

The examination was multiple choice, consisting of 160 questions. Questions 1-30 were 5 point questions with five choices each and required minimal calculations; 31-60 were 10 point questions, again with 5 choices each, but required more calculations. Also, questions 31-60 were sometimes grouped together -- eg. sometimes the same data was used for 5 questions; 61-100 were true/false questions of 2 points each. The T/F questions were lumped in sets of 5 questions, each set dealing with one specific topic. Thus the series of 160 questions dealt with 20 separate topics and required no calculations. (PART II of the examination, i.e. therapy physics/diagnostic/nuclear, also followed the same pattern as this part of the examination)

1. Energy of electrons decreases monotonically with depth in a phantom. (T/F)
2. Molecular motion produces radiation in the UV range. (T/F)
3. Given atomic number of 2 different material, the efficiency of bremsstrahlung will greater for which one. (5 pt. question)
4. TLD glow curve will be decided by preannealing method before irradiation. (T/F)
5. T Pair production in an electron field is called triplet production. (T/F)
6. RBE the ratio of (T/F) *RBE of same test radiation r*
7. T Dosages of radiopharmaceuticals must be dispensed under a fume hood according to the NRC. (T/F)
8. What contributes to the population dose? (5 points)
 - 1) P-40
 - 2) x-ray exposure
 - 3) Rn
 - 4) C-14
9. A 32-bit computer is one with a (5 points)
 1. 32 bit bus
 2. 32 bits in the memory
 3. 16 bit bus

*Bus - group of 20 lines
all used for data
= bus.*

*26 = 16 + 8
1 1 0 1 0*

F 10. The x-ray in electron capture comes from the parent (T/F) — daughter
Semenov page 30

*26 same case as alpha = 11010 = 5 bits
HSCII = 11010 = 5 bits
HSCII = 11010 = 5 bits*

1. At an altitude of 5 km there is a pressure change by a factor of two. If an exposure measurement is 0.115 R for a 1.0 minute exposure, what will the reading be at 2280 feet under the same conditions using the same instrument? (10 points)
A. .110, .115, .120, .125, .130
2. An anode rotating at 2800 rpm and the temp rises to zzz Deg C, radiation given off is xx (units). At 3000 rpm, the temp rises to yy deg C, the radiation emitted will be _____.
(σT^4) (10 points)
3. Mass of 100 g lies on a table. Coefficient of static friction is 0.5. What is the force required to move it? (10 points)
4. Exposure rates (Answer 10 mR) .6 sec, 25 mA (125 mAs). Exposure given. mA-min/week given. Convert mR received for that exposure
Work load in mA-min/week given. The exposure for a 0.6 sec, 25 mA exposure is xxx mR. What will be the exposure received in one week?
5. 100 g of water cools from 40 deg C to -40 deg C. All factors provided. What is the heat given off?
6. Iodine and Tech-99, half lives given. Total activity 10000 counts at a certain time and XXX after 12 hours. What was the initial activity of Tc-99?
(Solve the simultaneous equations.)
7. The potential energy given. 90 % is transferred to the bow. What is the initial velocity of the bow?
($\frac{1}{2}mv^2 = 0.9 \text{ energy}$)
8. Electron velocity = 0.9 c. Relativistic K.E.: Newtonian K.E. = ?
(mass = 1.25 m_0)
9. Capacitance = 100 pF. Voltage changes from 250 to 200 V. Volume of chamber = 10 cc. Density of air = XX./ Find the exposure in R.
(use $2.58 \times 10^{-4} \text{ C/kg} = 1 \text{ R}$) (10 point)

(T/F) Operational amplifier.
10. Amplification is ratio of the two resistances
11. The -ve potential is magnified.
12. It is an emitter follower.
- 13.
- 14.
15. Islets of langerhans are found in the pancreas. (5 point)
16. Hematocrit is? (5 point)
17. Plasma volume is _____ % of the blood? (5 point)
18. Iliac crest (L-5/L-6) (5 point)
19. Where are the adrenals located (5 point)

20. The alveolus are found in the ____? (5 point)
21. What does the change of CO₂ take place?
(Arterioles, venules, capillary beds, ...) (5 point)

Physiology and anatomy: 20 five point questions, 40 T/F

Which of these are related to the endocrine system?

22. (T/F) pituitary
23. (T/F) thymus
24. (T/F) adrenals
25. (T/F) testis
26. (T/F) pancreas
27. What is the hormone secreted by the parathyroid control?
(I, Na, K, Ca, Fe)
28. hypothyroidism, ocular problem, relate to Iodine therapy
for thyroid???????
29. Which valve leads to the left ventricle? (mitral valve)(5
point)
30. Which endocrine gland is the master gland? (5 point)
31. Lymphomas are associated with what types of cells?
(hematopoietic)
32. Which of these sarcomas will have the highest CT numbers?
(Osteosarcoma)

5 T/F questions on the eye.

33. The blind spot is due to the fovea.
34. The color vision is due to cones.
35. (Scotopic or)Photopic vision is night vision.
36. Resolution of the eye is 1 minute of arc.
37. Spatial resolution of eye increase with decreased frequency.
38. Aqueous humor (5 point)
39. Food is digested in the small intestine/stomach/pancreas/large
intestine/.... (five point)
40. Where does max absorption of water occur? Rectum, colon, small
intestine, jejunum, stomach (5 pt.)
41. $P_1 = 3p_2$, $T_1 = 22 \text{ deg C}$, $V_1 = 0.5 v_2$. What is the new T of
the body. (5 pt)

5 T/F on lasers.

42. The eye is the most sensitive organ to low power infrared
laser
43. Population inversion is necessary for laser

44.

5 T/F on TLDs

45. The preheat decides the glow curve.

46. It is operated in pulse mode.

47. The output depends on LET.

48. The black body radiation from the planchet can be reduced by using an ultra violet filter.

49.

50. The radiation due to gyrations for to proton-spin interactions is in the radiofrequency range. (T/F)

5 T/F on ultrasound.

51. The diameter of the wave increases in the Fresnel zone

52. As the frequency increases, the spatial resolution increases.

53. The frequency can be increased by increasing the potential across the transducer.

54. 4000 ion-pairs are produced by 1 Mev beam of electrons. This number is equal to how many coulombs? (5 pt)

5 T/F on electrons

55. The practical range for a 4 MeV beam of electrons is 2 cm.

F 57. The maximum dose occurs at the surface

58. The specific ionization reduces with depth.

59.

5 T/F on radionuclides produced by (n, gamma) reactions

T 60. The radionuclides decays by beta minus

F 61. It can be carrier free

F 62. The atomic number remains the same.

63. *Specific activity (Ci/g) very low for (n, gamma) rxns because of unaltered stable carrier (daughter material)*

5 T/F on electron capture

64. T Electron capture can occur with energy $< .5$ MeV $Ca^{42} = 0.884$

F 65. Characteristic x-rays are given off by the parent

66. *daughter*

67. Tc-99m decays to Tc-99. Tc-99 is a _____ isotope? (5 Pt)
Long lived/stable/ *T_{1/2} = 10⁵ yrs*

68. 1 MeV photon undergoes compton scatter at 90 degrees. What is the energy of the electron? (5 pt)

69. The compton interaction (μ/ρ) in one material is given. What is the mass compton interaction in the higher Z material going to be. (5 pt)

70. The Z, A and μ/ρ for Na and I are given. What is the

μ/ρ for the compound NaI? (10 pt)

71. The total angle between the Compton photon and Compton electron is 180 degrees. (T/F)
72. Convert 20 deg F to Celsius. (5 pt)
73. Scoliosis of the lumbar spine is imaged PA because:
reduces dose to the breast/reduces dose to the thyroid/pt is comfortable/penumbra decreases/increase in image distortion. (5 pt)
74. A G counter has an RC constant of 2 sec. It read 15 mR/hr in 4 sec. What is the true reading? (10 pt)
75. $N = 8$, $T_0 = 1.6$, given 3 Gy. What is the surviving fraction. (Exact same question in ABMP with $n=1$!!!). (10 pt)
76. Refractive index given. What is the velocity of light in the medium? (5 pt)
77. The effect of 80 R to whole body will be:
Depressed platelet count for some time/CNS syndrome (5 pt)
78. Given coeff of linear expansion, length and 25 deg C temp rise. Calculate the new length. (5/10 pt)
79. The exposure rate is X mR-cm²/hr. What will be the exposure rate at 2.5 m if .55 mm Pb is present in the beam. (HVL = .3 mm Pb, given) (5 pt)
80. The number of photons that are intercepted by .5 m² area at a distance of 8 m in 15 seconds from a source emanating 1000 photons per second. (10 pts)

5 T/F NRC regs regarding source storage

81. You can eat in the storage area if the sources are properly stored.
82. You must secure radioactive material if no one is present.
83. The packages from the radiopharmaceutical company can be thrown in the trash after the radioactive labels have been defaced if they do not show a reading.
- 84.

5 T/F (Anatomy/Physiology)

85. Proper histological methods of defining cancer of the lung epithelial
86. Adenocarcinoma
87. small cell carcinoma

5 T/F (Anatomy/Physiology)

A mammogram showing carcinoma of the breast shows:

- 88 Changes in the soft tissue density
- 89 Microscopic densities
- 90 Change in the skin thickness
- 91 Concentration of adipose tissue
- 92

93. Proper size of chemical to see perfusion of the lung:
0-1 micrometer, 1-2, 3-5, etc (5 pt)

5 T/F. Parts in the knee joint:

- 94. Patella
- 95. Humerus
- 96. Radius
- 97. Tibia
- 98. Transverse ----- muscle.

99 Longest phase of the cell cycle is _____ (5 Pt)

100. Bones in the forearm are _____. (5 Pt)

5 T/F. Which of the following participate in food digestion?

- 101. Small intestine
- 102. Gall bladder
- 103. Liver
- 104. Stomach
- 105. Pancreas

106. The proportion of blood volume that is plasma is _____ (5 Pt)

5 T/F. Parts of the male urogenital system

- 107. Ureter
- 108 Urethra
- 109 Seminal vesicles
- 110. Ovaries
- 111. Nephrons

112. Which of these organs is the most radiosensitive (5 Pts)
Uterus/small intestine/stomach/

113. Mean = 100 with a S.D of 10. What is the probability that a measurement will fall between 90-110. (5 Pt)

Y 114. There are 64 numbers numbered 1-64 in a bin. Six of them are selected at random without replacing any. What is the probability of drawing six of them in a consecutive order? (5/10 pt)

115. How many bits are required to identify all the lower case letters of the English alphabet? (5 Pts)

116. Ten numbers (0-9) are put into four bits. The 0 by mistake is offset to 1001. What will the number 7 be in the computer? (5 pt)
01, 001, 0101,

- 5 T/F on the noise that can be generated in the digital signal cable.
- 117.
118. A 20 MHz oscilloscope (5 pt)
 A. Cannot measure a frequency of more than 20 Mhz.
 B. Has a bandwidth of 20 MHz.
119. The velocity of the train and the freq. of the whistle are given. Velocity of sound given. Train is approaching the station. What is the frequency of the sound that a man on the platform will hear? (10 Pt)
120. The length of the wire is doubled as is the area of the wire. The resistance of the wire will _____. (5 Pt)
121. Given the optical densities produced for two different exposures and the slope of the H&D curve, what is the ratio of the two exposures? (5 Pt)
122. Given the increase in dB of 30. What is the increase in the potential applied? (5 Pt)
123. Ratio of the turns in a transformer was given. Given an input RMS (primary) voltage, what is the peak output (secondary) voltage? (5 Pt)
- None of the questions required one to remember any constants, except probably $1R = \underline{\hspace{2cm}}$.
124. MTF of various components of a gamma camera are given. What is the total MTF of the system? (5 Pt)
125. T/F. All atoms with even number of nucleons have a gyromagnetic ratio of 0.
126. The maximum energy of photon from an x-ray tube will occur for:
 constant potential high frequency generator/ 3-phase generator/ single phase generator (5 Pt)
127. Which is the best method of measuring the energy of the particle: p-n junction diode/G counter/0.6 cc ionization chamber/large volume chamber/NaI detector (5 Pt)
128. For fluorescence used in dosimetry the photon to electron conversion takes place at:
 diode/dynode/anode/NaI x-tal/cathode (5 Pt)
129. Given μ in g/cm^2 . Density given. For 90 % attenuation, what is the thickness in cm of the attenuator? (10 Pt)
130. High energy photons are incident on a layer of tissue. Thickness of the attenuator is exactly equal to the maximum

range of backscatter electrons. The Kerma is more than _____ absorbed dose.

5%>, 5%<, 10% >, 10%<, (5 Pt)

131. T/F. Photodisintegration cannot occur at energies < 1 MeV.

132. 5 T/F. Tc-99m decaying to Tc-99 is an isomeric transition.

133. What type of cells cause lymphomas? (5 Pt)

Part Q of exam: 20 questions, 5 Points each; 40 Questions, T/F 2 points each (Total: 180 points)

Part P: 30 questions, 5 points each; 30 questions 10 points each, 100 True/False questions in groups of 5, 2 points each. (Total: 650 points)

5 T/F on natural background radiation levels.

134. The dose from diagnostic > dose from nuclear exams

135. The dose from terrestrial > dose from diagnostic

136. The dose from radon > dose from diagnostic

137.

138. 100 R given to 10,000 people causes 10 excess cancers. If 10 R are given to 100,000 people, how many excess cancers will it cause? (5 Point)

139. The attenuation coefficient will be greatest for the photoelectric effect for (5 point)

A. L shell B.E. = 9 keV, photon E = 7 keV

B. L shell B.E. = 9 keV, photon E = 11 keV.

C. K shell B.E. = 88 keV, photon E = 87 keV

D. K shell B.E. = 88 keV, photon E = 91 keV

E.

140. T/F. There are no alpha emitters for $A < 30$.

141. Given number of atoms in the tissue. Diameter of one atom given. Find weight of tissue. (5/10 Pt)

5 T/F on the ROC phantom.

142. True positives are along the y-axis.

143. The area under the curve relates to....

144. The AAPM ROC phantom can be used for this study

145.

T/F

146. The energy given off in nuclear fission is approximately 1 MeV per nucleon.

147. The binding E per nucleon first increases, reaches a broad maximum and then slowly decreases. (T/F)

148. Given the energy, calculate the Compton wavelength of the

particle. (5 Pt)

149. During electron capture an anti-neutrino is ejected (T/F) *T*

150. Given the gamma, distance and activity, calculate the dose rate at a certain point. (10 Pt)

151. The resolution of a gamma camera for use with Tc-99m can be improved by: (5 Pt)
use of longer parallel collimator/pin-hole collimator/thicker NaI x-tal/
Sorenson

ABR OCTOBER 1992 Part II - Radiation Therapy
Praveen Dalmia

Questions 1 - 30: 5 pts. (5 choices); 31 - 60: 10 pts. (5 choices); 61 - 160 (T/F): 2 pts.

1. In contemporary radiobiology, the equivalent radiation dosage [worded differently in exam] is that dose that can be predicted by the curve for: (5 point)
 - 1) Single-hit-multi-target theory
 - 2) Single-hit-single target theory
 - 3) Multi-hit-single-target theory
 - 4) Multi-hit-multi-target theory
 - 5) linear-quadratic theory

2. An anterior superclav 12 x 4 cm field is to be treated on a 80 cm SSD Co-60 unit. The table is turned 90°. By how much should the gantry be rotated to make one edge of the field perpendicular to the floor? (5/10 point)
answer: 2.9°

3. The minimum temperature for hyperthermia treatment of cancer is: (5 point)
 - 1) 43°
 - 2) 40°
 - 3) 38°
 - 4) 47°
 - 5) 50°

4. The dose rate at the end of a 15 cm cone is 230 cGy/min. An air gap of 2 cm is found for a certain treatment. What is the dose rate on the skin? (5 point)

5. Given an unfiltered 10 mCi Ra-226 source, find the exposure rate at 2.25 m from the source if it is shielded by X cm (given) of lead and the HVL is Y cm (given) of lead. (10 point)

6. The activity of a Co-60 source is 1500 TBq. What would be the activity be 3 years from now? (5 point)

7. An exposure rate of 0.8 mSv/hr is measured outside when a linac without a beam stopper is irradiating a wall. Assuming a dose rate of 2 Gy/min at 1 meter, what will be the exposure per week outside. (Assume the WUT to be 60 Gy/wk.) (10 point)
answer: 0.4 mSv

8. Given WUT = M rad/wk, P = 0.01 R/wk (uncontrolled area), X outside = N mR/hr for a technique of T rad/min; how much extra shielding (HVLs) is required for the wall. (N, M, T were values provided) (10 point)
answer: answer came out to 0

9. The increase in percent depth dose per cm of lung for a 6 MV beam is: (5 point)
- 1) 2%
 - 2) 3%
 - 3) 4%
 - 4) 5%
 - 5) 6%
10. The decrease in PDD in bone for a 6 MV linac beam is: (5 point)
- 1) 2%
 - 2) 3%
 - 3) 4%
 - 4) 5%
 - 5) 6%
11. When making a tissue compensator for a photon field to compensate for sloping surface of the patient, (5 point)
- 1) the thickness of the compensator should be reduced according to electron density of material to that in water
 - 2) the compensator should cover the entire field
 - 3) it should be placed on the patient
 - 4)
 - 5)
12. According to TG-21, the depth of calibration for photon beams depends upon the diameter of the chamber and energy of the beam. This depth: (5/10 point)
- 1) is decided by length of electrons' track in the chamber
 - 2) should only be between surface and d_{max}
 - 3)
13. The A_{wall} correction according to TG21 is due to: (5 point)
- 1) fluence correction only
 - 2) fluence and
14. A mistake is discovered in the factors used for C_{TP} correction during calibration. The physicist used 20°C instead of 22°C as the standard temperature. The easiest way to correct for this is to: (5 point)
- 1) Multiply all Dose/MU by 293/295
 - 2) Ignore it; the error is within NCRP guidelines.
 - 3) Reduce future temperature measurements by 2°C.
 - 4) Add 0.01 to all Dose/MU.
 - 5)
15. There is a leak in the gas filled chamber mounted inside a linac. As the day progresses, the (10 point)
- 1) Dose/MU will increase
 - 2) Dose/MU will decrease
 - 3) Dose/MU will remain the same
 - 4)

16. A double flattening filter is used in a linac to (5 point)
- 1) make the beam flat
 - 2) reduce photon contamination
 - 3) reduce low energy electrons in beam
 - 4)
 - 5)
17. In the diagram below, angle theta for the isodose line shown (%age of isodose line was not given) will be: (10 point)

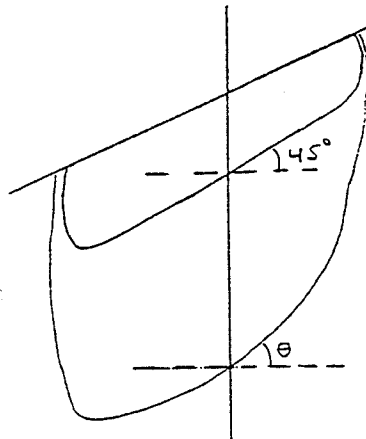

- 1) 15°
 - 2) 25°
 - 3) 35°
 - 4) 45°
 - 5) 49°
18. A 0.10 uCi source gives 12000 cpm in a well counter. What is the maximum cpm allowed by the NRC for a Co-60 wipe test? Ignore background, statistical fluctuations in counts and in instrument. (5/10 point)
 answer: Allowed is 0.005 uCi. $12,000/0.1 \times 0.005 = 600$ cpm.
19. A magnetron in an ordinary linac operates at the peak power of: (5 point)
- 1) 1 - 2 kW
 - 2) 2 - 20 kW
 - 3) 20 - 200 kW
 - 4) 200 - 500 kW
 - 5) 2000 - 5000 kW
20. Patient is treated with 3 fields, SSD treatment, each at 100% at d_{max} . A dose of 200 rad is prescribed to the 238 rad isodose line. What is the given dose from each field? (10 point)
21. A treatment plan calls for a 30° wedge in the beam. After three treatments, it was found that the wedge was facing the wrong way for 1 of the 3 treatments. The angle of the isodose was planned to be 30°, but will now be _____ for the combination of the 3 treatments. (10 point)
- 1) 10°
 - 2) 15°
 - 3) 20°
 - 4) 25°
 - 5) 30°
22. The flatness of an electron beam is most dependent upon (5 point)
- 1) position of photon field defining collimators
 - 2) material the cones are made of
 - 3) thickness of the electron foil
 - 4) energy of the electron beam

- 23. The SFD = 125 for a simulator, 100 cm SSD treatment field size measured on the film is 1.9 x 9.6 cm. The blocking tray on the linac is 65 cm from target. What will be the field size at the bottom of the tray? (10 point)
answer: (1 x 5 cm)
- 24. The $E_0 = 20$ MeV for an electron field. What will be the mean energy of the beam at a depth of 6 cm? (5 point)
- 25. The dose for a V-film is (5 point)
 - 1) 0.05 - 0.2 Gy
 - 2) 0.8 - 1.5 Gy
 - 3)
 - 4)
 - 5)
- 26. Calculate the SAR for the horizontal beam at X. Ignore off-axis factor. (The SARs for various radii at this depth were provided. Depth was 5 cm. (10 point)



- 27. A bubble is noticed near the top of the Hg column in a barometer. Which of these is definitely true? (5 point)
 - 1) if the bubble is removed, the pressure indicated will be lower
 - 2) the barometer must be recalibrated before use.
 - 3) air has entered the column
 - 4)
 - 5) any of the above is possible
- 28. A wedge (shown) has a sloping surface which is covered[?] by an 8 x 8 cm field. The wedge is used to treat a 10 x 10 cm field as shown in the diagram. What will be the hottest point in the treatment field? (10 point)

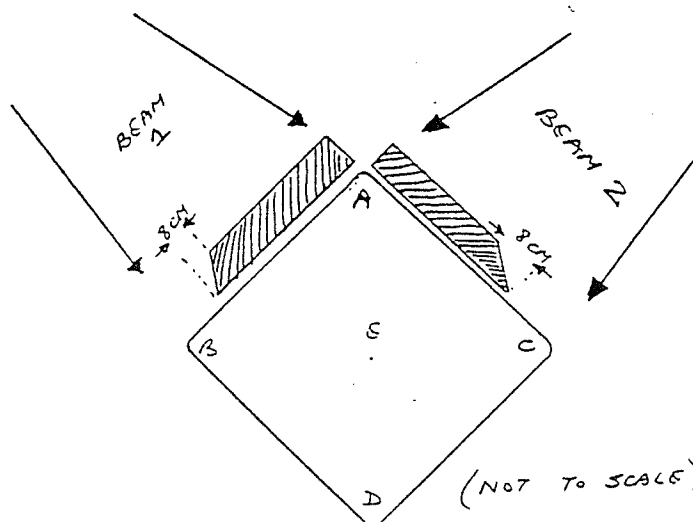

- 29. The decrease in neutron fluence for a 5 meter maze is by a factor of _____ ? (5 point)
- 30. The average exposure rate and max exposure rate at 1 cm from Co-60 teletherapy units' head is given. The activity of the source in the unit is given. What source strength is the head rated for? (10 point)
- 31. Given the initial dose rate of an I-125 permanent implant, what will be the total dose delivered? (5 point)

For questions 32-36 you're provided with a PDD table with BSF and a TMR table for a 6 MV linac. The output graph at 100 cm SSD at d_{max} is also provided.

- 32. Calculate MUs needed to deliver 300 cGy for an AP field 5 x 10 cm, at a 5 cm depth; SSD technique. (10 point)
- 33. Calculate dose delivered to a point 10 cm deep for the above field using PDD. (10 point)
- 34. A treatment delivered a 125 SSD; calculate MUs required to deliver 200 cGy to a point 7 cm deep for a 12 x 15 field. (10 point)
- 35. Calculate MUs required to deliver 200 cGy for an isocentric treatment using TMRs from 12 x 15 anterior field at a depth of 10 cm (Separation = 20 cm). (10 point)
- 36. Calculate dose to cord which is 4 cm from posterior edge from both AP and PA fields. (10 point)

For questions 37 - 43 you're provided a TAR and PDD table with BSF. Co-60 unit; Dose rate at 80.5 cm under full scatter conditions given.

- 37. Calculate TMR for given field size and depth. (10 point)
- 38. (10 point)
- 39. (10 point)
- 40. (10 point)
- 41. (10 point)

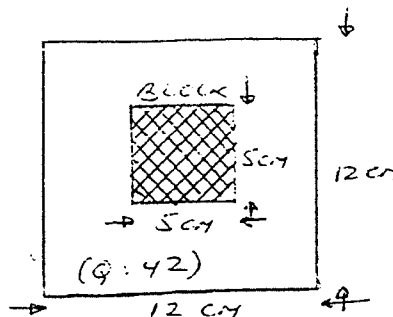

- 42. Calculate PDD under the block at a depth of 5 cm. Ignore block transmission. (10 point)
(SEE FIG. ABOVE)
- 43. (10 point)
- 44. How many TVLs are required for a Co-60 unit's beam stopper shielding? (10 point)
(1) 1 (2) 2 (3) 3 (4) 4 (5) 5

Questions 61 - 160 were T/F type for 2 points each. They were in groups of 5; i.e., a statement followed by 5 questions. Thus there were 20 groups of 5 questions each. Each group dealt with a specific topic.

Questions 61-65: in a linac

61. All linacs have at least one magnetron.
62. In a traveling wave linac, the particles gain energy only in the drift cavities.
62. In a 6 MV linac, the target, magnetron and thyatron are not water cooled.
64. The magnetron's frequency can be changed by ± 1000 Hz.
- 65.

Questions 66-70: 2 people want to compare their barometers.

66. The comparison should not be made if a storm is expected between the 2 facilities.
67. Comparison should be made at more than one point.
68. If the two don't match and it is later found that one is correct, then an additive correction can be applied to the incorrect one.
- 69.
- 70.

Questions 71-75: In an aneroid barometer:

71. Some of them, in case of a large pressure change, can move around more than one circle.
72. A temperature correction must be applied to the reading.
73. In case the high pressure gas in it leaks, it must be repaired and not used.
74. Care must be taken regarding its physical orientation when used.
- 75.

Questions 76-80: NRC requires that a full calibration be conducted whenever:

76. A primary wall shielding is changed.
77. The teletherapy physicist on the license changes.
78. The license is renewed.
79. When work is done on upper collimator.
- 80.

Questions 81-85: NRC requires that:

81. Co-60 source be wipe tested every 6 months.
82. Source changed every 5 years.
83. Inspection be an OEM employee every 5 years.
84. The Co-60 wipe test also test for leakage of Uranium in depleted Uranium collimators.
- 85.

Questions 86-90: What instrument(s) does the NRC consider O.K. for leak testing of a Cs-137 source.

86. GM counter survey meter.
87. Large volume ionization chamber survey meter.
88. NaI crystal with a PMT tube and a single channel analyzer.
89. A Ge crystal with a multichannel analyzer.
- 90.

Questions 91-95: For I-125 brachytherapy seeds:

91. The dose rate drops linearly with distance because the inverse square law fall is made up by scatter.
92. The _____ (?) activity is greater than actual activity.
93. Can give off radioactive gas if punctured.
- 94.
- 95.

Questions 96-100: In hyperthermia

96. The temperature measuring device only causes a problem if it conducts and gets overheated.
97. In microwave heating at depth, the dose absorbed is inversely proportional to water content.
98. Ultrasound is used for heating whenever there is an air gap or bone present.
98. SAR is measured in units of _____ with _____
- 100.

Questions 101-105. The Clarkson integration calculation can be readily used

101. To get an isodose plot for an off-axis point.
- 102.
- 103.
- 104.
- 105.

Questions 106-110: Regarding wedges

106. They can only be used in pairs.
107. A 45° wedge made for 10 cm field will have a greater attenuation than one made for an 8 cm field.
108. A wedge made of Pb will be thinner than a wedge made of copper for same field size and beam energy.
109. In regular clinical practice, a wedge angle of $180^\circ - (2 \times \theta)$ gives the best results.
110. One can simulate any wedge angle with a combination of an open field and a 45° wedge.

Questions 111-115: Regarding shielding for a simulator:

- 111. More than 1/8" Pb or more is usually not required.
- 112. Pb is usually attached on the wall board.
- 113. 1/8" Pb glass is equivalent to 3 mm Pb sheet.
- 114.
- 115.

Questions 116-120: In the isodose computer plot shown below

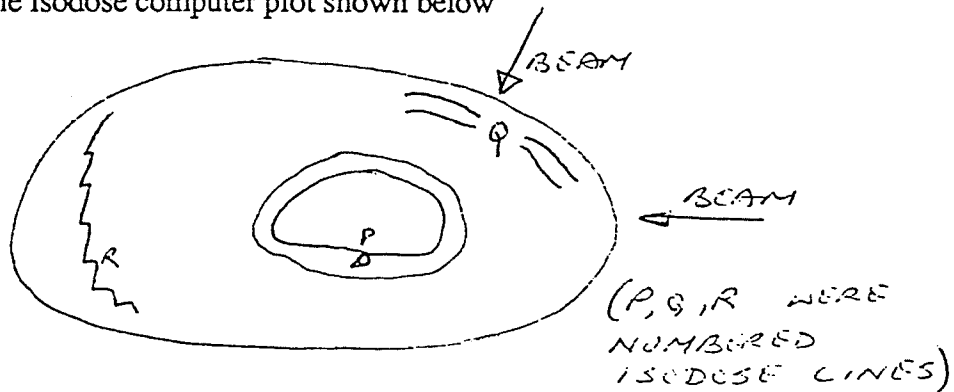

- 116. The angles labelled R are artifacts.
- 117. P is actually smooth.
- 118. Q is actually continuous
- 119.
- 120. You can tell the computer algorithm used by looking at the plan.

Question 121-125: Packaging of Ir-192 sources before they are shipped back by the hospital to the supplier:

- 121. The package requires a yellow III label if surface dose rate is greater than 50 mR/hr.
- 122. The papers required for shipping have to be DOT pre-approved and is the hospital's responsibility.
- 123. The package has to be DOT approved.
- 124. If the source has been leak tested by the manufacturer, the hospital need not do anything else.
- 125.

Questions 126-130. An NRC surprise inspection of a licensee's practice

- 126. Can take place outside of working hours.
- 127. Can be unannounced.
- 128. It can check activities being conducted and correlate them with letters to the NRC written by the licensee and previous inspection reports.
- 129.
- 130.

Questions 131-135: A survey meter is calibrated with a 30 mCi Cs-137 source in air. It can be used to:

131. Measure P-32 exposure rate.
132. Measure exposure rate around I-125 brachytherapy patient.
133. Survey a room for shielding when conducted with a portable x-ray unit inside the room.
134. Survey a contact therapy unit room for shielding when conducted with a Co-60 source kept in the room.
- 135.

136. In a rotational therapy treatment plan, the wavy lines near the isodose lines near the surface are due to the effects of opposing fields.

December 15, 1992

Peter J. Rosemark, Ph.D.
Cedars-Sinai Comprehensive Cancer Center
8700 Beverly Boulevard
Box 48750
Los Angeles, California 90048-0750

Dear Peter:

I was recently notified that I passed all three sections of the ABR written examination, so the following points may have some merit.

Take the course, "Physicists [sic] Review in Radiation Oncology Physics." It is given at

University of Texas Health Science Center at San Antonio
Continuing Medical Education
7703 Floyd Curl Drive
San Antonio, Texas 78284-7980

Telephone: 512.567-4444

FAX: 512.567-6964

The course director is Robert G. Waggener, Ph.D. 512.567-5597

The blurb about him states

Dr. Waggener served on the ABR Physics Exam Committee for 10 years, ABR Physics Committee for 4 years and the ABR Therapy Written Exam Committee for 6 years. He participated in the initial development of the American Board of Medical Physics.

The one-week course covers the basics necessary to pass the exam given by "...different instructors with extensive backgrounds in radiation oncology physics and experience with board certification..." It also includes a coursebook with approximately 900 questions and answers. The course is good for several reasons: (1) it creates an oasis where one can focus one's attention on the subject matter without constant interruption; (2) it brings to light areas of weakness that need remedial attention; (3) it is a class environment where one can speak with the lecturer and classmates during breaks; and (4) one can socialize with classmates after class to reach a better understanding of the material presented.

The ABR provides outlines of the material to know for the exam.

Review the outlines carefully.

**The written examination tests for
retention,
rapid recall &
stamina.**

Know how to convert everything to SI units and work problems in SI units.

Know dosimetry to the extent that the physical basis of A_{eq} can be described.

Physiology should be known to the extent that the major organ systems as well as their functions are committed to memory. For example, one should be able to identify the islets of Langerhans, the master gland of the endocrine system and the circulatory system including the chambers of the heart with respect to oxygenation of the hemoglobin among other things.

Anatomy should be known to gross detail including the sensory organs and major systems. For example, a question asking one to identify parts of a knee joint included bones, soft tissue and insertions should not be a problem; not all of the choices presented pertained to the knee.

Radiation biology should be learned to the extent that the principle reactions, methods and time-frames of interactions are known on microscopic and macroscopic levels; know cell cycles, susceptible organs, end points, dose levels for various effects including organism death and cell death, and the basic principles of therapy. Know the chapter summaries of Hall's text.

Statistics should be learned to the extent that the difference between Poisson and Normal distributions are known and why Normal distributions are used when radioactive decay is described by a Poisson distribution. Know the standard deviation of a Poisson distribution and when the difference between two means is significant. Identify and have a working knowledge of t-tests and z-scores.

Shielding should be known to the extent that specific problems can be solved when characteristics of a machine are given along with measurements outside of the treatment room. Know how to convert to units that used by the low-energy and high-energy cases for the primary, secondary and scattered radiation formulae. Know maze design principles for photons and neutrons.

There were three examinations as follows:

Day #1	General Radiological physics	3 hours
	Clinical aspects	1 hour
Day #2	Practice of Radiological Physics	3 hours

Structure of the examinations is all multiple choice; no essay questions were presented. However, the questions in the beginning portion of an examination require one to solve a problem worth maybe 20 points. If one is sloppy and does not include all factors in order to save time, then haste makes waste for incomplete answers seem to have been on the choice list for some of the problems. Work thoroughly and swiftly, but be sure not to waste time on these

problems. If the problem cannot be solved quickly, then drop it and keep on going. The questions at the rear of each examination are worth maybe 5 points; however, one can easily identify the correct answer by inspection if the answer is known. So, one strategy that suggests itself would be to quickly read over the entire examination to locate the easy throw-away questions and then get them behind. Next go to the weighty problems in an assembly-line fashion with a firm time-limit on each problem.

One point of note. The rules state that no programmable calculator can be used. For those who use Reverse Polish Notation calculators, this is bad news because Hewlett-Packard only manufactures programmable RPN calculators. Perhaps if the ABR Physics section were to be made aware of this problem and that Hewlett-Packard calculators have a clear-program function, then this nuisance could be avoided in the future.

Suggested material:

The Physics of Radiology
Johns & Cunningham

The Physics of Radiation Therapy
Faiz M. Khan

Radiobiology for the Radiologist
Eric J. Hall

ADVANCES IN RADIATION ONCOLOGY PHYSICS
AAPM Monograph No. 19

CLINICAL ONCOLOGY
FOR MEDICAL STUDENTS AND PHYSICIANS-
A MULTIDISCIPLINARY APPROACH
Published by the American Cancer Society

The Anatomical Chart Series
by Peter Bachin & Ernest Beck
A Comprehensive collection of classic Anatomical Charts
in a New Desk Size Version
Published by
The Anatomical Chart Company 800.621-7500
8221 Kimball
Skokie, Illinois 60076

For those people fortunate enough to have a Macintosh computer, the MicroMath MMCalc calculator works in both algebraic and Reverse Polish Notation. Also it has several hundred constants with the capability of the user adding more. In addition, it can work with common units and convert those units to SI units. For example, one can divide 10 Joules by 0.25 kilograms and obtain the answer in SI units. The calculator carries out complex arithmetic, Gaussian arithmetic including the resulting standard deviations, statistics and calculates the number of days between dates for decay problems. It can evaluate virtually any polynomial that you write and reevaluate the function after some of the values of the independent variables have been changed; this may be more convenient than bringing up an EXCEL spreadsheet. It has many other functions as well. Think of it as the Swiss Army knife of Macintosh calculators that can be brought up while running any other program.

MMCalc
MicroMath Scientific Software
Salt Lake City, Utah 84121

801.943-0290

Thank you for providing the review material for the ABR examination.

Sincerely,

ABR EXAM 22-23 SEPTEMBER 1993
THERAPEUTIC RADIOLOGY

I. The first part was one hour of clinical questions. They were very easy and mostly consisted of questions related to physiology. There were no radiographs or CT's where you had to identify the organ. A review of basic anatomy and physiology would be necessary to pass this part.

Some of the areas of interest/questions were:

- parts of the ear
- parts of the eye
- function of cones and rods (which were more abundant)
- blood flow through the heart (oxygenated, not oxygenated)
- organs in the mediastinum
- hormones produced by the thyroid gland
- what cancers are malignant
- mets from breast cancer occur where
- facts about the thymus gland
- where is the circle of Willis
- lymphatic system
- identify proteins and amino acids and what are their function
- what is the cell permeable to
- some sort of ejection fraction volume
- how many liters of blood in the body
- what is the most radiosensitive stage in the cell cycle
- what is the transfer protein in the cell

PART I: (General) Was a mix of questions ranging from basic physics on up. Included multiple choice and true and false with about five true and false questions about one subject. They were weighted differently (note this in the exam booklet). I did the true and false first to get me through the initial panic.

There were a lot of general diagnostic questions mixed in, especially in the true and false. A review of Christenson would be necessary.

- electricity, Ohm's law, circuits in serial, parallel, batteries in series
- car on a bridge 20 meters long. How much does it weigh to either side if it is 7 meters across the bridge.
- angular momentum
- compton equation for photon and scattered electron
- secular and transient equilibrium equations
- electromagnetic radiation (frequency, wavelength, velocity)
- kerma calcs
- decay schemes, calculate energy
- grams to atoms
- conversion to AMU in calculations
- charge on a 10 -6 cc chamber exposed to 10 mR

- HVL of 100 kev photons from an x-ray machine
- many HVL, TVL, u, T 1/2 calculations
- how far will a 3 MEV beta particle penetrate the skin
- given film sensitometry strips to calculate OD and gamma and speed of film
- optical density calcs
- neutron calcs (how many are produced from linear accelerator)
- calculation of biological and effective half life
- MIRD type calculations
- counting statistics (standard deviation of the counts)
- general questions about hyperthermia (need to know the basic theory and precautions)
- alot of general diagnostic questions in ultrasound, MRI, contrast, film, processors

PART II - MEDICAL PHYSICS

Divided into three sections of multiple choice and true and false with the multiple choice weighted differently. The middle section was the most difficult and time consuming. Again went to the true and false first.

- Co-60 PDD tables, linac TAR and TMR tables given had to calculate isocentric TMR treatment, dose to spine given a dose at isocenter, PDD calc to depth beyond isocenter. Had to manipulate data and use correct charts to calculate dose in air and convert to dose in phantom. Most calibrations were at dmax.
- Extended SSD calculation
- calculate penumbra from Co-60 source
- size of an object in a tray to project a certain size at 100 SSD
- gap calc
- table kick and collimator angle for cranio-spinal set up
- shielding calcs all in TVL for primary, scatter and leakage for diagnostic unit, Co-60 and linac
- neutron shielding in a door
- length of a maze
- shielding for a safe containing Cs and Ra.
- along and from calcs for tandem in Cs insertion.
- Co-60 timer error calc
- virtual SSD calc
- depth dose curves from scanning water phantom-what were wrong with them (gantry not at 180, probe not level, collimator rotated...)
- shielding of a box for shipping to reduce dose to 2 mr/hr
- electron calibration questions
- Rp, range for electrons
- effective path length calc for inhomogeneity
- TMR missing tissue calc for compensator
- treated at incorrect SSD what is the percent error
- treated on wrong unit 6/100 rather than 12 MeV unit what is the error

- treat on a linac and transfer patient to Co-60 80 SSD, what is the change in field size
- effects of wedging
- showed scanned wedge profile (what's wrong with this picture)
- scatter and leakage from accelerator and Co-60
- calculation of dose from exposure
- brachytherapy equivalent doses to Ra-226
- doses at bone and tissue interfaces for both photons and electrons
- true and false questions:
 - TG-21 protocol for photons and electrons
 - electrons
 - depth dose (field size, SSD, depth)
 - hyperthermia
 - NRC regulations
 - Quality Management Program questions
 - occupational exposure limits (old standards)
 - dosimetry (Fricke, parallel plate)
 - parts of a linear accelerator and their function

1993 WRITTEN 22-23 Sept 93

GENERAL

1. Given a copper coin 3 cm in diameter with a 3 mm diameter hole in the center, if the coin is heated to a temperature of _____° and the coefficient of linear expansion is _____, what is the size of the hole?
 - A. 2.995 mm
 - B. 2.998 mm
 - C. 3.0 mm
 - D. 3.002 mm
 - E. 3.005

2. We were given the decay scheme for Na-22 to Ne-22 and asked for the energy in MeV for a given part of the scheme. I don't think there was any right answer. Everyone I talked to was baffled, as none of the multiple choice answers could have been right.

THERAPY

1. What would be the barometric pressure if you went from sea level to 1 km height?
 - A. 720
 - B. 740
 - C. 760
 - D. 780

There were lots of TMR/PDD questions using tables to solve the problem.

DIAGNOSTICS

1. Five True/False questions on lithotripsy.
2. Five True/False questions on screens-very basic on what they do.
3. The Fourier Transform of this

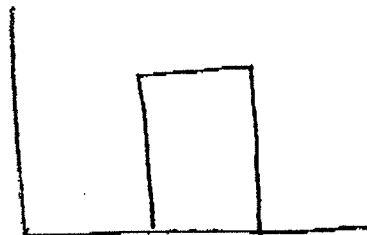

would look like this

A.

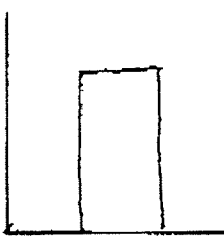

B.

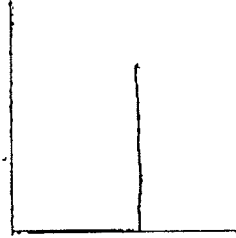

C.

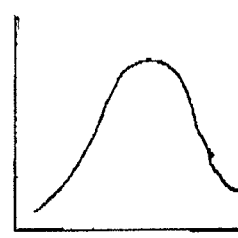

D.

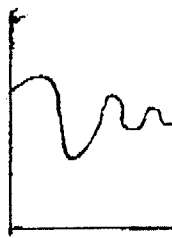

4. Given an ROC study with these results

30 True Positive

40 False Positive

10 True Negative

20 False Negative

what is the specificity? (There were 4 multiple choice answers.)

what is the sensitivity?

5. Given a 10 cm CT chamber, 10 mm slice thickness, 10 mm step increase for 10 slices, the chamber reading is 300 mR, what is the slice dose?

6. For the same chamber, slices changed to 5 mm slices, 5 mm step, what is the slice dose?

7. Needed to know Intensity ~ $(kVp)^2$

8. Needed to know 15% increase in kVp, then cut the mAs in half to get similar image quality/density.

9. True/False, are these chemicals in the developer?

A. Sodium thiosulfate

B. cellulose nitrate

C. hydroquinone

D. sodium sulfate

E. potassium bromide

10. Needed to know imaging CSF in MR- concerning T1 and T2 weighted images.

Peter Rosemark,
Radiation Therapy,
Ceders-Sinai Medical Center,
8700 Beverly Blvd.,
North Tower, Lower Level,
Los Angeles, CA 90048.

15th Oct.94

Re: ABR exam

Dear Peter,

I have just taken the written radiation therapy physics boards, and am devastated by the difficulty of part I. The first exam, called "clinical physics" was 100 multiple choice questions in 1 hour. A far greater number of questions were on physiology than anatomy, but unexpectedly, I found this exam the easiest of the three. Part I was fiendishly difficult with very few questions related to radiation therapy, but a large number related to diagnostic imaging procedures. I found part I ludicrous, and many of the questions ill-worded, ambiguous and totally unfair. In fact, there was a mis-numbering of the last 5 questions, which should have been from 146-150, but were printed as from 151-155, leaving us in some doubt as to where to answer them on the answer sheet. Two of the questions had diabolical misprints leaving the examinee in total confusion. Part II on Radiation Therapy Physics was very tough, but for the most part fair. Part I and II are 3 hrs for 150 multiple choice questions, which is about 1min 10 secs per question. I found this far too short, since 50% of the questions were calculational, and many non-trivial. The time pressure is therefore immense, and its like taking an IQ test and not a medical physics exam. The format of each paper was approximately 60% multiple choice questions, and 40% true/false questions. The latter true/false questions were much easier than the multiple choice ones, but carried much less weight, i.e. only 2 points per correct answer instead of 5 or 10. My advise is to jump to the second half of the questions, and do them first and then to come back to the first half later, since the hardest questions tend to be at the beginning, and some of them

took me 5 minutes to perform, only to find that I got an answer which didn't agree with any of the 5 answers provided.

I am writing a letter of complaint about part I to the ABR, since even the exam session proctor agreed that the number of misprints should have been eliminated in the proof reading. Many people had questions to the proctors about the wording of certain questions. The information in the pink booklet about the questions not requiring a calculator is a lie. Without a good calculator, it would be very tough to do at least half of the questions, unless you can do exponentials and cosines in your head, which perhaps is expected of a good medical physicist these days!

I was under the false understanding that if I knew Khan, I would pass the boards. Half of the questions were not or very peripherally touched by Khan. After seven years as a medical physicist, nothing could have prepared me for these board exams.

I have attempted to remember as many of the questions as I can, but the whole thing is a hazy mess in my mind. Therefore excuse me if some of the questions don't make complete sense.

Best wishes

Clinical Physics (Anatomy and Physiology)

Multiple choice

- 1) What structure in the eye contains the sensory cells for vision?
- 2) In which body structure can you find the anvil, stirrup and cochlea?
- 3) Which is the best diagnostic modality to detect multiple sclerosis?
- 4) Which is the best diagnostic modality to detect a slipped disc?
- 5) What is the prime function of the colon?
- 6) What is the function of the gall bladder?
- 7) Where is the pancreas located relative to other major organs?
- 8) What is the procedure called to repair a tubular fraction?
- 9) Which disease is most commonly associated with a vitamin C deficiency?
- 10) What of the most radio-sensitive structure of the digestive system?
A stomach B small intestine C colon D rectum E pyloric sphincter
- 11) Which tissue type is the most sensitive to radiation in the body?
A GI tract B skin C hematologic D CNS E lung

True/False

Which of the following are important ingredients of blood?

- 50) sodium
- 51) manganese
- 52) urea
- 53) fibrinogen
- 54) iron
- 55) calcium

Which of the following functions are performed by the kidney?

- 56) water resorption
- 57) electrolyte balance
- 58) bile excretion
- 59) regulation of blood pressure
- 60) detoxification

Which of the following organs are to be found in the mediastinum?

- 61) vena cava
- 62) esophagus
- 63) lymph nodes
- 64) kidneys
- 65) diaphragm

Which of the following are proteins?

- 66) hemoglobin
- 67) triglyceride
- 68) collagen
- 69) aldosterone
- 70) amylase

Which of the following are ball and socket joints?

- 71) elbow
- 72) knee
- 73) hip
- 74) wrist
- 75) ankle

Which of the following are malignant neoplasms?

- 76) hematoma
- 77) adenoma
- 78) craniopharygioma
- 79) melanoma
- 80) colorectal polyps

Part I

Multiple choice

- 1) A truck is traveling 20m/s on a 30° incline and weighs 20 kilonewtons. If the coefficient of friction is 0.6, what distance will the truck travel before coming to a stop?
- 2) What is the angular momentum of the moon? The mass of the moon and the distance from the Earth to the moon are given?
- 3) An ion chamber exposed to a radiation field of 10R/min produces a current of 1 nanoampere. If the density of air is $1.293 \times 10^{-3} \text{ g/cm}^3$, what is the volume of the chamber?
- 4) The focal length of a lens is 17cm. If an object is placed 5cm from the lens, between the lens and the screen what is its magnification?
- 5) What is the indefinite integral of e^{-ax} ?
- 6) The exposure rate from a source is 10 R/min at 1 meter. How many half-value layers are required to reduce the exposure rate to <10mR/hr at 8 meters from the source?
- 7) The door to a new radiation therapy facility is installed backwards so that the steel faces inwards and the borated shielding material outward. The largest dose to a radiation therapist at the console would arise from:
A) 10 keV neutrons B) 10 keV photons C) 500 keV photons D) 2MeV photons E) 10 MeV photons
- 8) A photon is scattered by 135° by a Compton interaction. The scattered photon has an energy 400 keV. What was the energy of the incident photon? (No equations given).
- 9) A source when counted in a well scintillation counter gives a reading of 5,000 counts in 30 secs. The background counts in 2 minutes is 500 counts. What is the standard deviation of the determination of the source activity?
- 10) A scintillation detector gives a reading of 5,000 cpm per microcurie of sample A and 14,000 cpm per microcurie of sample B

with a fully open window. Two unknown mixes of A and B are counted with two separate windows. The readings were as follows:

	window 1	window 2
mix 1	5,000	25,000
mix 2	40,000	0

What is the activity of sample A ?

11) You are transporting a brachytherapy iridium source. The exposure rate at 1 meter from the pig is 50 R/hr. How much extra shielding is required to reduce the output so that it falls below a transportation index of 10. (I had never heard of this term before, and nor had anyone else who participated in the exam with me).

12) The total energy of P-32 is 1.17 MeV. What is the mean neutrino energy? (I thought this may have been a misprint, since the total energy of decay for P-32 is 1.71 according to my recollection).

13) What is the energy of a KM Auger electron emitted by copper? The binding shell energies were given.

14) What is the heat generated in a rotating anode, given its dimensions? The operating kV and mA were given and the specific heat of the target material.

15) A 24g cobalt-59 target is placed into a reactor with a neutron flux of 10^{13} neutrons/cm².s. How long will it take to generate a 20 Ci source? The cross section of the (n, γ) reaction was provided.

16) Continuing from the last question, how long will it take before Co-60 reaches 80% saturation?

17) the lasers used in a CT unit are usually
A) helium B) argon C) YAG D) carbon dioxide E) other

18) What is the Larmor precession frequency of a proton in a 2 Tesla magnetic field?

19) Given 10^{10} cells, and the mean lethal dose is 100 cGy, how much dose must be given to ensure only a 1% probability of 1 cell survivor?

20) Given the $D_{37} = 150$ cGy and the $D_0 = 100$ cGy of a survival curve, calculate the extrapolation number?

21) What is the principal cause of the shoulder on a survival curve?

22) What is the maximum permissible dose to a fetus?

True/False

Relative to a high frequency diagnostic X-ray tube, which of the following about a diagnostic machine operating with a 3 phase power supply are true?

50) image contrast is greater

51) amount of heat generated in the target is greater

52) efficiency of the tube is greater

53) focal spot is larger

A gamma camera operated with 512×512 compared to 256×256 pixels has?

54) greater source resolution

55) greater signal/noise ratio

56) requires a greater computer capacity

57) improved image contrast

A patient is given a 100 mCi dose of P-32 as an outpatient procedure. Which of the following recommended guidelines are true?

58) the regulations governing patients administered P-32 is the same as brachy patients administered I-125 implants

59) the patient should be advised to sleep alone for the first few nights

60) the patients sheets should be washed separately from the rest of the family

61) visits by children less than 18 years should be minimized

62) the patient should use a separate toilet

A teletherapy unit uses a uranium collimator. Which of the following are true?

63) it is made from natural uranium

64) it is under NRC regulation

- 65) tapping holes in the collimator is unsafe
- 66) regular surveys of the collimator activity are mandated

For a simulator, which of the following are true?

- 67) the grid ratio is 1:16
- 68) a timer is mandatory on all fluoroscopy units
- 69) there are mandatory exposure limits for simulator techs working in front of a fluoroscopy unit.

Part 2

Multiple choice

In this section there were a large number of monitor unit style calculations similar to the type in the Raphex books. Most were straightforward, although a few had some tricks in them.

- 1) What is the current definition of point A?
- 2) What is the definition of the wedge angle?
- 3) A full brachytherapy source inventory is required every?
A) month B) 3 months C) 6 months D) year E) 2 years
- 4) How would you determine the TMR at 20 cm depth given a TAR table for the appropriate machine?
- 5) This 3 field question, I spent 10 minutes on, and am still not sure I know how to do it.
A 3 field pelvis is planned by hand. The anterior field is normalized to 100% at D_{max} , and the 2 lateral fields are normalized to 70% at D_{max} (wedge factors = 0.7). Given that 200 cGy is delivered to the 135% isodose line, what is the dose given through the anterior field?
The figure below was given with no further information.

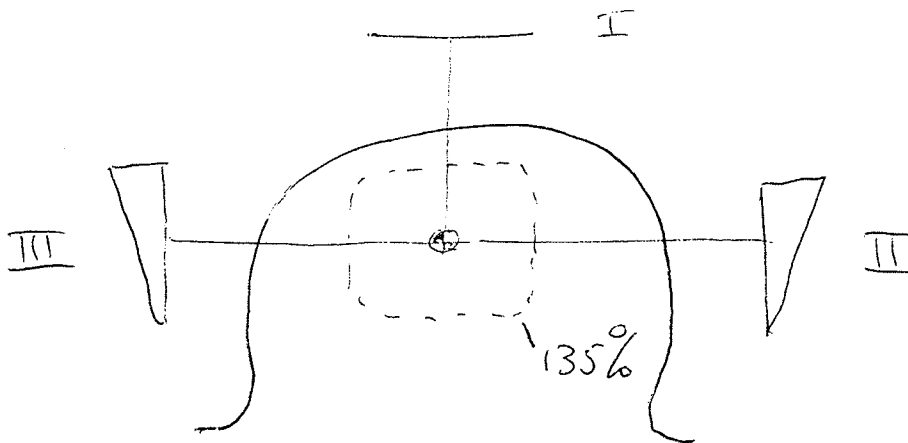

6) A room next to a radiation therapy room has use and occupancy factors of 0.25. 50 patients are treated per day at a dose rate of 400 MU/min. When the machine is operated at 200 MU/min the exposure rate is 250 R/min at isocenter. The distance to the next room is 5 meters, and the wall is designed for 8 HVL's. Does the adjacent room:

- A) meet NCR requirements
- B) requires no additional shielding but a radiation safety shield must be hung on the door
- C) 1 additional HVL
- D) 2 additional HVL's
- E) a greater number of HVL's

7) When commissioning a new linac with 6 MV and 15 MV photons and 6 MeV, 10 MeV, 15 MeV and 20 MeV electrons, you should determine the neutron dose for which selection of beams?

8) In a tandem and ovoid case only one colpostat is loaded with a 55 mg Ra equivalent source. What is the dose to a point X marked on two films (you are given an anterior and a lateral film photon containing the position of the source and the dose calculation point with a grid overlaid to determine distances)?

9) What is the wavelength of the microwaves travelling down a 6MV linac?

10) What are the AAPM task group guidelines for the frequency with which a treatment planning system should be checked?

11) What provides the greatest contribution to the dose from an I-125 implant

- A) gamma rays
- B) fluorescent photons
- C) Auger electrons
- D) beta rays
- E) internal conversion electrons

12) Given a permanent I-125 implant. What is the fraction of the dose which is administered in 38 days?

13) Why is P_{ion} greater for a linear accelerator than a Co-60 unit?

14) Why is a parallel plate chamber preferred over a cylindrical chamber for the calibration of an orthovoltage unit?

15) Why is a monitor chamber required on a linac?

16) What is the reason for the disappearance of the horns on photon beam profiles at increasing depths?

17) On which electron machine is the bremsstrahlung highest? With a single scattering foil, a dual scattering foil or a scanned beam?

18) What is the average energy of an 18 MeV electron beam at a depth of 5 cm?

19) An unknown beta source has a range of 60 micron in tissue equivalent plastic after traversing a 0.5 mm lead shield. What would be the range of the beta particles in plastic if the lead shield were removed? (the density of the plastic was given but not of lead).

20) What is the kerma of a 10MV beam, given a photon fluence of 10^9 and $\mu_{tr}/\rho = 0.0320 \text{ cm}^2/\text{g}$ and $\mu_{en}/\rho = 0.0315 \text{ cm}^2/\text{g}$?

21) Calculate the correction factor for the dose to an off-axis point at a depth of 5 cm for a 100 cm SSD treatment, if there is 3 cm of missing tissue? Use the effective SSD method.

22) What is the energy of an electron beam whose R_{50} is 18 cm in water?

23) What is the ratio of the dose to a point behind a heterogeneity of 1cm thickness for an electron beam vs no heterogeneity given the density of the heterogeneity is 2.5 g/cm^3 relative to water which is 1.0 g/cm^3 , and the electron density of the heterogeneity is $3 \cdot 10^{23}$ electrons/g relative to water which is $3.34 \cdot 10^{23}$ electrons/g?

24) Using the data above estimate the same fractional dose for a photon beam?

25) A photoelectric interaction occurs in a low Z element of tissue. What is the most likely emission from that atom
A) A characteristic x-ray B) an Auger electron C) a u.v. photon D) visible light E) a neutron

True/False

When commissioning a set of new wedges, which of the following must be measured?

- 50) wedge factor vs. depth
- 51) wedge factor vs. field size
- 52) wedge factors off-axis
- 53) wedge factors for the averaged chamber reading at 0 and 90 degrees
- 54) wedge factors for the averaged chamber reading with the collimator at 0 and 180 degrees

According to TG40, which of the following should be measured monthly?

- 55) rad/light coincidence
- 56) output at different gantry angles
- 57) centricity of wedge trays

For an ultrasound hyperthermia unit, which of the following is true

- 58) ultrasound is reflected from air bubbles
- 59) the tissue penetration of ultrasound decreases with increasing wavelength
- 60) the depth of the penetration of the usable beam increases with increasing size of the applicator
- 61) a non-conducting temperature probe does not conduct electricity

When calibrating a linac with an ion chamber, according to TG21 guidelines, in an acrylic phantom compared to water which of the following are true?

- 62) the light field on the surface of water and phantom are the same
- 63) the light fields at the chamber depth are the same
- 64) the water and phantom surface must be at the same distance from the source
- 65) the phantom size must be at least 15 cm diameter

When comparing a Geiger-Mueller to an ionization chamber radiation safety monitor, which of the following are true

- 66) has more expensive electronics
- 67) is more sensitive to damage if roughly treated
- 68) is the instrument of choice for tracing a lost brachytherapy seed
- 69) exhibits a higher sensitivity for instruments of the same size

When a film badge is manually read-out instead of automatically which of the following are true

- 70) it can be determined whether the radiation source was anterior or posterior to the patient
- 71) if the TLD machine breaks down, there is a method to recover the signal by manual read-out
- 72) the read-out can be altered if it is dropped
- 73) the read-out can be altered if it becomes dirty

ABMP Radiation Therapy Part II 1994 (Anaheim, CA)

These questions were recalled by a group of Wayne State graduates while eating a delicious Chinese meal after the test. I found the questions recalled by others in past years VERY helpful - and if you are using the study guide I hope you take the time after your wonderful test taking experience to write down what you can remember for the future generations of victims (including yourself in the unlikely event that you have to retake it).

We had 3 hrs 50 min to answer 151 questions. I did not have a time problem (I had over an hour to spare after going through all the questions once) - but some of the others just finished the test. Not that going fast is good - while the discussing the questions I realized that I had missed some key points of questions (i.e. question requested acute and not the late effects, the use factor was requested for the nursing station ABOVE the room).

The questions are not in any particular order. The K type answers are not in the correct order either. The asterisk (**) marks indicate the answer we think is correct. Have fun. (P.S. - I think we all passed!!!)

1. Field matching problem

Given: thickness of patient at the adjacent fields: 18 cm
 thickness of patient at gap junction: 20 cm
 field size, SSD(?) setup, mid-depth

Calculate the gap on skin if fields match at middepth.

2. For 1 mCi Au-198, what is the total dose delivered in mg-Ra-eq-hr

3. For I-125 permanent implant which delivered 12,000 cGy total dose, what is the dose delivered after 4 months? (9000 cGy)

4. What is the isotope effective for bone mets?

- (a) 30 mCi I-131
- (b) 4.0 mCi Sr-90
- ** (c) 4.0 mCi Sr-89
- (d) P-32

5. Primary beam stopper should have what % transmission:

- ** (a) .1%
- (b) 1%
- (c) 10%

6. Which organs are present in the treatment of the stomach (K type)

- (1) liver
- (2) spleen
- (3) spinal cord
- (4) lt kidney

7. The original isocenter for the treatment of lung was placed at midline of the patient. If the isocenter is moved laterally to the center of the target volume, the dose would increase to (K type)

- (1) contralateral lung
- (2) ipsilateral lung
- (3) target volume

8. The incidence of pair production,
- increases with E and with Z
 - increases with E^2 and with Z^2
 - decreases with E and with Z
 - decreases with E^2 and with Z
9. The purpose of the following for stereotactic (K type)
- MRI to see lesion
 - MRI to see function of tissue
 - CT
 - digital angiography less distortion
10. For total skin electron irradiation, the purpose of placing Pb shielding on nails is (K type question)
- there is disease under the nail @ the beginning of stages
 - oblique incidence of electrons damage nails
 - high Z material of nail

Match the constant with what would uniquely be needed for calculations of the following factors

- exposure rate constant
 - inverse square
 - 8.25
 - .876
- (11) energy absorption rate
 (12) radium equivalent
 (13) air kerma rate
- (14) For 500 kVp - 10 MV - what are the interactions in this range?
- lowest end of Compton
 - highest end of photoelectric
- (15) For 25 MV photon, what do you need to shield against (K type)
- slow neutrons
 - gamma
 - fast neutrons

Match the fractionation scheme with its characteristic

- conventional radiation therapy
 - hypofractionation
 - hyperfractionation
 - accelerated repopulation fractionation
- (16) higher prescribed doses (c)
 (17) more dose over shorter period of time (b)
 (18) one fraction per day (a)
- (19) Limit of leak test of sources in Bq (185 Bq)
- (20) The amount energy absorbed by 1 g of tissue receiving 100 cGy
- changes with photon energy
 - changes with e- energy
 - same for all photons

**

(21) What would cause significant change in the dose rate of output of a linear accelerator (K type)

- ** (1) shift in flattening filter
- (2) defective MU ionization chamber
- ** (3) PRF changed

(22) Characteristics of microwave generation in linac (K type)

- ** (1) magnetron produces microwaves
- (2) Frequency range 3000 kHz
- ** (3) klystron amplifies microwaves

(23) For 6 MV photons (K type)

- (1) frequency of microwaves 3000 MHz
- (2) change energy

(24) What are table requirements for radiosurgery?

- (1) accurate vertical movement
- (2) accurate horizontal movement
- ** (4) table isocentricity

(25) To convert O.D. to dose for an aperture smaller than 1mm for a film scanner, need to know (K type)

- (1) sensitometric curve
- (2) effective Z of the film
- (3) stopping power fraction @ depth (?) of e- in the film (?)
- (4) W/e for film

Match the scaling factor for e- with the material

- (a) .975
- (b) .99
- (c) 1.00
- (d) 1.05
- (e) 1.15

(26) clear polystyrene

(27) condensed polystyrene (white?)

(28) solid water

(29) acrylic

(30) For a tissue compensator made of equivalent thickness of tissue (K type)

- ** (1) overdose past the depth of calculation
- ** (3) dimensions of compensator minimized

(31) What are the acute effects for craniospinal irradiation (K type)

- (1) low IQ
- (2) alopecia
- (4) nausea and vomiting

(32) The cord is

- ** (a) posterior to vertebral body
- (b) anterior to vertebral body

- (33) What is the superficial dose at .5 cm compared to the surface dose?
(a) 70%
(b) 100%
(c) 105%
(d) 110%
- (34) What is the magnitude of dose enhancement for 9 MeV electron treated to depth of 2 cm
(a) 60-70%
- (35) For a 70 kV superficial simulator has (K type question)
** (1) transmission target
** (3) grid to reduce scatter
- (36) For x-ray production (K type)
(1) cathode has high melting point
(2) generator has constant rotation (???)
(3) most heat generated in target
- (37) Point A defined (K type)
(1) 2 cm lateral @ level of colpostat
(4) 40-60 Gy/hr
- (38) Portal films (K type)
(1) better with ready pack film
(2) require less MU if use cassette
(3) Co-60 has better resolution
- (39) What needed to determine the size of the tumor? (asked twice, K type)
(1) TFD and target @ isocenter
(3) TFD, TSD, depth
- (39) 80% of field length if used to determine the flatness. The area enclosed is what % of the total area?
(a) 50%
(b) 64%
(c) 80%
(d) 89%
- (40) CT used for (K type)
(1) correct for inhomogeneities
(2) 3-D treatment planning
(3) display isodose curves in off axis slices
(4) scan @ any treatment position
- (41) Shielding for IORT (K type)
(1) Pb strips
(2) cerrobend
(3) lucite
- (42) For 5 cm error in setup, the % PDD change is
** (a) 1%
(b) 2%
(c) 5%
(d) 10%

- (43) An SAD setup with 10x10 field at isocenter is changed to an SSD setup. What changes (K type)
- ** (1) collimator setting
 - ** (2) MU setting
 - ** (3) field size @ tumor
 - ** (4) field size on skin
- (44) For total skin electron irradiation, you place a lucite plate close to the patient because (K type?)
- (1) monitor dose rate
 - (2) dose uniformity
 - (3) minimize x-ray component
- (45) ACR Physical Aspects of (Quality Assurance in Radiation Therapy?) recommends what quality assurance (K type)
- (1) wedge and compensator
 - (2) block cutter
 - (3) block device
- (46) AAPM #41 HDR standard recommend quarterly check of (K type)
- (1) timer error
 - (2) timer accuracy
 - (3) length of applicators
- (47) Question from AAPM # 13 standards
- (48) Question about what wedge factor is dependent on (K type)
- (1) field size
- (49) What are the late effects of Stage IIA Hodgkins disease? (K type)
- (1) pericarditis (?)
 - (2) pneumonitis
 - (3) Secondary cancer
 - (4) alopecia
- (50) Given:
- Patient thickness is 24 cm thick
 - Distance from source to floor = 2.3 m - patient treated on floor
 - @ 100 SAD, the field sizes are 35 cm and 40 cm in length respectively
 - If the fields match at the surface of the patient, find the amount of overlap of fields at midline of the patient
- (51) If change waveguide, what would you check (K type)
- (1) energy
 - (2) flatness
 - (3) output
- (52) If change the magnetron, what would you check (K type)
- (1) bending magnet
 - (2) light/radiation field alignment
 - (3) output
 - (4) flatness

- (53) NRC regulations after changing the source of the teletherapy unit requires
- (1) light/radiation alignment
 - (2) dose rate
 - (3) accuracy
 - (4) remeasure PDD
- (54) For therapeutic I-131 treatment,
 Given: activity, gamma constant, effective T1/2 = 18 hrs, limit must be less than 5 mR/hr @ 1 m
 Calculate the time required before can release
- (55) For prostate treatment:
 lateral separation = 40 cm, AP separation 28 cm
 What are the weightings AP/PA, and lateral (K type)
- (1) 1.5 1.5 1 1
 - (2) 1 1 1.5 1.5
 - (3) 1 1 2 2
 - (4) 2 2 1 1
- (56) What is the appropriate approach to boost dose to cervical nodes after cord tolerance has been reached (K type)
- (1) e-
 - (2) obliques
 - (3) add block to lateral fields
 - (4) 3-field
- (57) What are appropriate modes of treatment of lung CA with curable intent? (K type)
- (1) AP-PA including with mediastinal and off cord boost
 - (2) and limit cord dose to 45 Gy
 - (3)
 - (4) Lateral fields each delivering 30 Gy

Match the use factor

- (a) 1
 - (b) 1/4
 - (c) 1/16
 - (d)
- (58) nursing station above ceiling
 (59) Primary wall
 (60) Occupational factor of outside corridor
 (61) use factor for secondary radiation

(63) TBI treatment calculation

Given: .091 cGy/MU @ 350 cm

At midline, SAD (SSD?) = 368 cm and TMR = .625

At ankle, SAD (SSD?) = 356 and TMR = .89 OAX = .9

Will deliver 200 cGy to midline

What is the dose to the ankle?

(64) TBI treatment (think treatment with opposing laterals)

Given: head thickness = 16 cm, TMR = .858
midline thickness = 40 cm, TMR = .56
each layer of compensator thickness transmits .9

Calculate how many layers of compensator thicknesses needed to decrease head dose?

- (a) 3
- (b) 5
- (c) 7
- (d) 9

Match the dosimetric system best suited for the following measurements

- (a) diode
- (b) parallel plate ionization chamber
- (c) film
- (d) TLD (?)

(65) dynamic wedge

(66) total skin electron dose rate

(67) skin dose

(68) patient in vivo dosimetry

(69) A diode (K type)

- (1) better spatial resolution
- (2) eV lower
- (3) energy dependent
- (4) tissue equivalent

(70) K type Question of electron backscatter, and what affects it (i.e. energy, and can be as high as 60%)

(71) What is the range of Dq for almost all in vitro systems (doses)

(72) What is D(0) (K type)

Match the treatment with the applicator

- (a) prostate
- (b) esophageal
- (c) cervical
- (d) vaginal

(73) Syed

(74) Fletcher

(75) DeClos

(76) Patterson Parker circle (think 6 seeds of Cs-137) - need to calculate dose, or time

(77) Minimum cerrobend thickness for 22 MeV e-

(78) Some anatomy question which asked whether epitrochlear nodes were involved

(79) K type question on how to lower fetal dose in mantle irradiation

- (1) Use of secondary shielding
- (4) treatment in an upright position

(80) K type question on characteristics of BSF

- (1) Can be as high as 25%

ABR 1994 (October 13&14) - Written Part I and Part II (Therapy)

When taking the ABR, one of the instructions is that a person will not copy the exam or give information about the exam. I am not sure what exactly the consequences of talking about exam is supposedly, but certainly information from past exams helped me study for this exam, so here are my thoughts and what I remember about the exams.

The content of the ABR seems to vary from year to year. This year Part I, clinical (1 hr) and general (3 hrs) was given Thursday afternoon, and Part II Therapy (3 hrs) was given on Friday morning. I think Part I and II tests consisted of 25 fifteen (15) point questions (54%), 100 T/F questions (2 pts each, 28%), and 25 five (5) point questions (18%) for a total of 700 points. Even though I felt I knew the content of ABR Part I from the notes of previous exams, I still felt unprepared for the exam of this year. My physics was definitely weak, but since these questions were generally worth 15 points each, not knowing a few questions, may impact more than I would want. If your physics is strong (they can ask so many things!!) then you will have less problems than I did.

Comparing the ABR and ABMP,

(1) Generally, the problem solving on the ABR was more involved than the problem solving on the ABMP. I don't recall any problem solving in Part I of the ABMP, while Part I of ABR had problems on physics, neutron activation, etc. I found ABR Part I more difficult than ABMP Part I. I felt pretty discouraged at the end of the test.

(2) The ABMP Part II scope seemed to be broader than the scope of ABR Part II (i.e. ABR asked minimal questions on the operation of a linear accelerator, no questions on special procedures such as total skin electron treatment, radiosurgery, HDR, or IORT). ABR Part II was practical - the calculations seemed more involved than ABMP (i.e. to arrive at an answer you may have needed to do three steps instead of one), but very straightforward. I had the feeling that if I did not study for ABR Part II, I still would have been in good shape because I do hand calculations on charts all the time at work.

The clinical portion was straight forward. I found the book The Language of Medicine (3rd edition, Davi-Allen Chabner) useful in reviewing the systems and the functions, although it is probably more detailed than you will be tested on. We did not have to identify any structures from diagnostic films (i.e. MRI or CT). Generally, you need to know the basic functions of organs and organ systems. Miscellaneous questions I remember:

T/F question on Kupffinger (sp?) cells

Hammer/stirrup/ are part bones of _____ (ear)

What diagnostic test is most useful for diagnosing multiple sclerosis (MRI)

T/F questions on indications for breast cancer
 non/multiparous woman
 woman who started menses late

Part I

Physics questions (either 5 or 15 point questions)

Given focal length and position of an object, calculate the lateral magnification

Given the mass of the moon and earth, and the distance between them, calculate the angular momentum.

Summation op amp

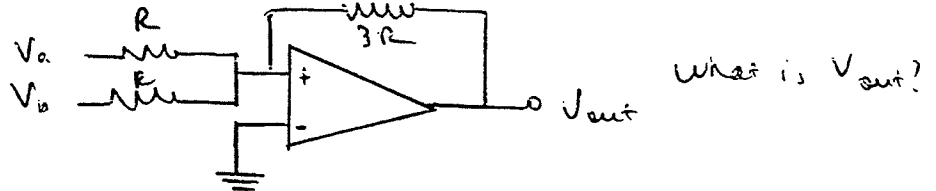

Given capacitance, and current, calculate the time required to obtain 50 V across the capacitor.

Given coefficient of friction, angle, and mass of object, calculate how far the block will travel before the object stops.

Type of laser used in CT unit (15 pt question!!)

Given experiment which involved 5 measurements, a chi square table, what value would be appropriate for a medical physics measurement.

Radiological physics questions:

At least 3 neutron activation questions:

(a) Given Cr-X1 becomes Cr-X2 with neutron activation, and the half life of Cr-X2, calculate the time required to obtain 80% of the saturation activity.

(b) Given 40 g of substance, neutron fluence, cross section, and half life of the daughter, calculate the activity after certain amount of time.

5 T/F on focal spot

(a) is bi-modal

(b) measurements made with pin hole is larger/smaller than with star pattern (not sure about the question)

Calculate the effective atomic number for CO₂

Part II: Some questions were multi-part (i.e. you would use the MU units you calculated from one question to determine another question). Co-60 (PDD, TAR, and graph of FSF and 6 MV (PDD and TMR) informaton was given.

Several questions required use of Mayneord f-factor

SSD setup

(a) calculate the MU's for midplane treatment

(b) calculate the MU's if the SSD is changed

(c) calculate the cord dose for AP/PA treatment

SAD setup

(a) calculate the MU's for midplane treatment

(b) calculate the dose to the cord for AP/PA treatment

If for course of 6000 cGy 30 fx, 10 treatments receive 20% lower dose, what would

Notes on questions from ABR EXAM of 14 October 1994, Atlanta, GA [sk and ml]
All questions are T/F or Multiple choice (for multiple choice, more than one right answer possible - choose all that apply) Many required calculations to be done.

Part I - General Physics
and Clinical Questions
Day 1, October 1994

1. Effective half-life
 ^{89}Sr : $T(1/2)_{\text{phy}} = 52$ days; $T(1/2)_{\text{biol}} = 26$ days.
How much after 26 days?
2. Committed effective dose from tritium radiation accident.
3. Majority of background radiation in United States from radon (True/False question).
4. Shielding for beta emitted in lead pig behind 1 cm of plastic.
How far does radiation penetrate the plastic?
5. Compton effect - energy of electron scattered 135° .
6. True/False about CE - Can you have more than one CE for a particular electron?
Minimum energy needed?
7. D_0 - extrapolation number - $D = 3 \text{ cGy}$, $D_0 = 1.5$
8. 18 MeV electron; 9 MeV electron - $0.999c$.
Velocity of electron.
9. Flux density.
10. Count Rate \rightarrow plus background problem.
Standard deviation
Units - μCi
11. TPC (temperature/pressure correction) - 20° , 770 mm Hg.
12. Resolving time - dead time - $4 \mu\text{sec}$ (?) per 300,000 cts - $c/1-c\tau$
13. Compton scatter: 135° - Energy $\rightarrow 0.024(1 - \cos \theta)$
14. Compton scatter - general.

15. Molecules - number in one liter of air.

16. Radiosensitivity (relative):

small intestine

stomach

meter (?)

bladder

Place above organs in order of increasing radiosensitivity.

17. True / False Questions

a. Fission products - Uranium

Cs, Mo

b. Thyroid imaging agents:

I-123, I-125, I-127, I-131

or Tc99m

c. Things you can tell from characteristic curve of film:

speed

latitude

contrast

MTF

spatial resolution

d. Activation by bombardment with Co-57. (May have been percent activation of Cr-52.)

e. Brachytherapy

f. Air kerma

g. MRI:

T1 - long - relaxation

T2 - transverse relaxation

h. Mammo - things you expect from Mo target:

effective energy

Use for mammo

i. Dosimeters: things you might be able to tell from reading TLD.

if exposure from background;

if TLD was overheated;
if TLD was dropped;
if exposure from single exposure.

18. Very little on CT.

19. Ultrasound - factors that attenuate beam.
mW of US beam
-density / thickness
- beam width

20. MRI / CT - which for seeing multiple sclerosis plaques. [MR is better.]

21. Op Amp - summing

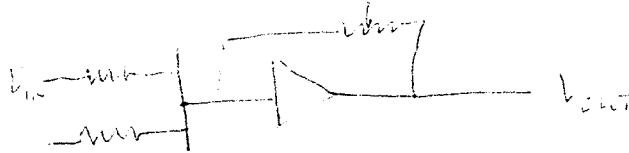

22. Ultrasound - 2 questions.

23. Pregnancy - limits for fetus

24. Breast CA - risk factors.

25. Fetal - preimplantation - growth retardation - effect of radiation.

26. Dose in gestation.
< 5 Rem, not higher; risk to occupational workers. Comparison.
5% spontaneous mutation rate.

27. Angular momentum: mom

28. Truck - 20 NT, 30° incline, 0.6 friction coefficient, 20 m/sec. How long before the truck stops?

29. Percent of beam hitting 100 sq. cm. at 50 cm.
steradians.

30. Lithotripsy - to visualize herniated discs.
myelography
CT
MRI

31. General - 2 curves
- What is average gradient?
32. Calculation problems - Count rate stuff
2 channels - Mix of two isotopes
Given count rate of A and B and readings of channel 1 and 2
How much of each isotope is in the mix?
33. Effective - dpm / cpm \Rightarrow μCi and counts
34. Is radiation related to latitude?
35. Volume of chamber , 1 mA, 0.6 --, 10 R/min
36. Solid state vs gas detector - why better?
37. Temp. kcal to J conversion. cGy [1cGy = 1 J/kg]

Clinical Questions

1. Mitral valve, bicuspid valve → left ventricle, pulmonary vein (circulation to the heart).
 - A. Blood from left atrium to left ventricle - what valve.
[Mitral valve → left ventricle
Bicuspid valve → pulmonary vein]
2. Flow of blood from inferior part of body through heart to lungs and back to heart.
3. Location of pancreas.
4. Positioning - pancreas - between duodenum and spleen, anterior to stomach.
5. Location of adrenal glands.
6. Sarcoma, adenoma, granuloma - which are cancers?
7. Types of neoplasms in colon.
8. Which are proteins?
collagen
hemoglobin
glycogen
streptokinase
triglyceride.
9. Which are normal components of blood:
urea?
10. Which of elements below are in blood:
Ca, Mg, Na, Tc, Fe
11. Function of liver - to detoxify.
12. Normal components of blood.
13. Normal conception: function of:
Prostate - also, what does it secrete.
Testes
Ovaries

14. Cell cycle - G1, G2, S, M
* M, G1, S, G2, M (what is correct order?)
15. Identify ear bones from list.
16. Which are Ball and socket joints? - ankle, knee, hip, elbow
17. Where are the cells of vision?
retina, lens, iris.
18. Function of pituitary gland - [controls thyroid].

Part II Diagnostics Radiological Physics
Proctor: Dr. Larry Davis
Second day, October 1994

1. Ultrasound -Fat-Kidney interface - amplitude of pressure wave.

2. Calculate K_{ub} [or K_{uB}].
- K_{UB} - 14" x 14" - 850 mrad on skin.

3. CT Questions - lots of questions.

A. CT - what kVp and mAs? How much dose per slice thickness?
Attenuation from table.

B. CTDI - calculate

C. Helical scanners - pitch dependent on what factors.

D. Fetal dose - CT scan; entrance exposure 850 mrads.

E. Shielding - CT scanner - operator.

F. Aliasing - frequency.

4. MRI - lots of questions

A. MRI - inversion
diagram

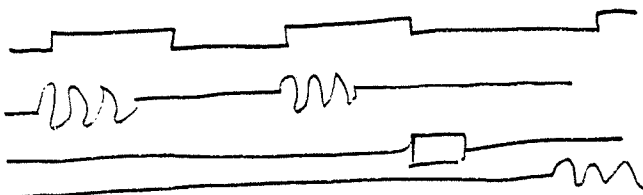

B. T1 weighted images

C. MRI Contrast agents -
Gadolinium - reaction?
Low osmolarity \Rightarrow less iodine?
Anaphylactic shock - contrast agents.

5. Air kerma - calculation

6. Megabyte computer storage space required for images:
30% head, 0.5 rad, 20 films, 17 patients/week
70% abdomen, 1.5 mrad, 17 patients/week

7. Mammography - lots of questions.

- A. Image Quality Mammo images.
O. D. = 1.2; dose = 150 mrem.
Reasons: pressure water marks; developer temperature.
- B. HVL of Mammo measured as 0.28 vice 0.3 of manufacturer. Possible reasons why.
- C. NEMA on mammo - target angle of tube.
- D. nit - candela, lux, ACR - viewboxes - minimum lux.
- E. Molybdenum vs Rhodium filters
- F. Breast biopsy - film; 5 cm; FFD = 60 cm.
- G. Star pattern - width of focal spot.
- H. Slit camera - focal spot size.

8. Image Quality - General - lots of questions.

- A. Factors affecting film speed - developer temperature, etc.
- B. Developer -
CaCO₂
Hydroquinone and phenidine
Restrainer - Ammonium thiosulfate additive
Br to increase activity.
- C. Which factors would improve contrast?

9. Kernel [0 1 1 0] [0. 0.25 0.25]

10. MTF: Calculate gamma, gradient given range of O.D. + log₁₀ E

11. Nothing on tomography.

12. Nothing on xerography.

13. How much scatter to technician two feet from fluoro machine?

14. Cardiac catheterization lab - FDA, NCRP recommendations.
What at what distance from image intensifier (II)?

15. Specificity - Sensitivity.

ABR PHYSICS TRUSTEE REPORT

by Edward Chaney
Chapel Hill, NC

The format of the ABR written examination changed in 1989. Since then enough questions have been accumulated to allow release of sample questions without significantly depleting the pool of questions with proven discrimination value.

In the current format the examination is divided into Part 1 and Part 2. Part 1 is further subdivided into a section on general physics related to all specialties, and a clinical section covering general clinical concepts that should be familiar to the practicing Radiological Physicist. Part 2 of the written exam is focused on the specialty area of the candidate (diagnostic radiology, radiation oncology or nuclear medicine). Each exam, except for Clinical, has 150 questions: 25 Easy Type A, 25 Hard Type A, and 100 Type X.

A Type A question is a multiple choice question. "Easy" and "Hard" describe the relative degree of difficulty, which is usually related to the amount of calculation necessary to reach the correct answer. A Type X question is a stem followed by four or five statements, each requiring a "True" or "False" answer. Easy A questions carry a weight of 5 points ($125/700 = 18\%$), Hard A questions carry a weight of 15 points ($375/700 = 54\%$), and Type X questions carry a weight of 2 points each

($200/700 = 29\%$). The Clinical exam comprises 20 Type A questions with a weight of 5 points each ($100/250 = 40\%$), and 75 Type X questions with a weight of 2 points each ($150/250 = 60\%$).

Sample questions from Part 1, including Clinical, are included in this report. These questions have proven to discriminate well between candidates who score in the upper and lower quartiles. Sample questions from the Part 2 exams will appear in the next newsletter. Additional copies of these sample questions can be obtained by writing the American Board of Radiology, 5255 E. Williams Circle, Suite 6800, Tucson, AZ 85711.

Reminder: Applications for the 1996 written examination are due September 30, 1995.

SAMPLE QUESTIONS FROM ABR PART I EXAM

EASY TYPE A

1. A current of $2.0 \mu\text{A}$ must flow into a 100 nF capacitor for how many seconds to produce a 50 volt potential difference across the capacitor?

- A. 1.0
- B. 2.0
- C. 2.5
- D. 5.0
- E. 25.0

2. Shortly after a tritium inhalation incident, it is found that the initial dose equivalent rate to a worker is 10 mrem/hr . The committed

dose equivalent in mrem for an effective half life of ten days is _____?

- A. 0.14
- B. 0.24
- C. 2.40
- D. 3.50
- E. 3460.00

3. The mass attenuation coefficient for 10 MeV photons in soft tissue is $0.022 \text{ cm}^2/\text{g}$. The probability that a 10 MeV photon will penetrate a 20 cm abdomen without interacting is _____.

- A. 0.002
- B. 0.01
- C. 0.44
- D. 0.64
- E. 0.77

SAMPLE - HARD TYPE A

1. After being Compton scattered at 135° , a photon has an energy of 250 keV. The photon energy before scattering was _____ keV.

- A. 260
- B. 290
- C. 490
- D. 1,520
- E. 11,600

2. A dose of 4 mCi of ^{89}Sr is used for treatment of a patient. The physical and biological half lives are 52 and 26 days, respectively. What will be the activity in mCi in the patient after 52 days?

- A. 0.25
- B. 0.5
- C. 0.6
- D. 1.0
- E. 2.0

ABR PHYSICS TRUSTEE REPORT

3. A ^{57}Co wipe test and a background sample are counted for 3 minutes using a well counter. Using the following information, determine the ^{57}Co activity in μCi in the wipe test sample: Data for 3 minute counts for wipe test and background samples:

^{57}Co sample : 1350 counts
Background: 450 counts
Well counter efficiency: 0.94 cpm/dpm

- A. 1.35×10^{-4}
- B. 1.44×10^{-4}
- C. 4.20×10^{-4}
- D. 7.65×10^{-3}
- E. 8.59×10^{-3}

4. What energy (kilojoules) is imparted to a rotating anode (0.25kg) during a two second exposure that produced a temperature of 2500°C (specific heat of tungsten is $0.035 \text{ kcal/kg}^\circ\text{C}$) and ($1 \text{ cal} = 4.186 \text{ J}$).

- A. 17.9
- B. 45.7
- C. 87.5
- D. 91.4
- E. 182.9

5. What fraction of gamma rays emitted from a point source will be incident on a 100 cm^2 detector at a distance of 50 cm ?

- A. 6.0×10^{-5}
- B. 1.9×10^{-4}
- C. 1.6×10^{-3}
- D. 3.2×10^{-3}
- E. 4.0×10^{-2}

6. What is the ultrasound pulse power (in mW) remaining after a 100 mW ultrasound

pulse loses 30 dB while traveling through tissue?

- A. 0.03
- B. 0.05
- C. 0.10
- D. 3.33
- E. 4.48

SAMPLE - TYPE X

Items 1-5

True statements about the focal spot in a typical diagnostic x-ray tube include which of the following?

1. It expands with increasing tube current.
2. It expands with increasing tube voltage.
3. It displays a bimodal intensity distribution.
4. It yields smaller measurements with a star test pattern than with a pinhole camera.
5. Its effective size depends on the measurement location along the cathode-anode axis.

Items 6-10

Recombination in an ionization chamber is more likely to occur with increased:

6. LET
7. dose rate.
8. polarizing voltage.
9. electrode space.
10. gas temperature.

Items 11-14

True statements regarding radiation and pregnancy include which of the following?

11. About five percent of live births have "spontaneous" malformations or congenital abnormalities.
12. The NCRP recommends an equivalent dose limit of 50 mSv (5 rem) to a fetus.
13. There is a lower risk of abnormalities associated with a diagnostic dose of less than 50 mGy to the fetus than with other risks normally associated with pregnancy.
14. Growth retardation commonly occurs during the pre-implantation period.

SAMPLE - CLINICAL QUESTIONS

Directions: Select the best answer from the five answer choices for each of the following items.

1. The kidneys are located:
 - A. inferior to the bladder.
 - B. above the adrenal glands.
 - C. anterior to the quadriceps muscles.
 - D. within the retroperitoneal space.
 - E. anterior to the pancreas.

ABR PHYSICS TRUSTEE REPORT

2. The normal sequence of structures encountered as blood returns from the lower extremities is:

- A. inferior vena cava, right atrium, right ventricle, pulmonary artery, pulmonary vein.
- B. inferior vena cava, right atrium, right ventricle, pulmonary vein, pulmonary artery.
- C. inferior vena cava, left atrium, left ventricle, aorta.
- D. inferior vena cava, left atrium, left ventricle, pulmonary artery, pulmonary vein.
- E. superior vena cava, right atrium, right ventricle, aorta.

3. The normal function of the prostate is to:

- A. store sperm.
- B. supply the energy for ejaculation.
- C. control the supply of testosterone.
- D. secrete a constituent of the seminal fluid.
- E. secrete prostaglandin.

4. Which of the following tissues is the most radiosensitive?

- A. CNS (brain)
- B. Cardiac
- C. Skeletal
- D. Thyroid
- E. Hemapoietic

Directions: Respond either true or false to each item as it relates to the preceding question or incomplete statement.

Items 1-5

The mediastinal structure includes the following:

- 1. Heart
- 2. Lymph nodes
- 3. Superior vena cava
- 4. Diaphragm
- 5. Esophagus

Items 6-10

Which of the following are functions of the liver?

- 6. Produces bile
- 7. Produces insulin
- 8. Makes white blood cells
- 9. Detoxifies blood
- 10. Controls adrenaline production

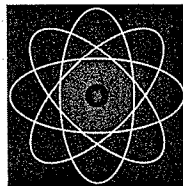

**EXAMPLE QUESTIONS FOR THE ABR
WRITTEN EXAMINATION IN PHYSICS**

Currently the written physics examination is divided into Part I and Part II. Part I is further subdivided into a section on general physics related to all specialties, and a clinical section covering general clinical concepts that should be familiar to the practicing Radiological Physicist. Part II of the written exam is focused on the specialty area of the candidate (Diagnostic Radiological Physics, Therapeutic Radiological Physics, or Medical Nuclear Physics). Each exam, except for Clinical, has 150 questions worth a total of 700 points: 25 Type 1A, 25 Type 2A, and 100 Type X. A Type 1A or 2A question is a multiple choice question. A Type 2A is more complex than a Type 1A, usually because more calculation or thought is required to reach the correct answer. A Type X question is a stem followed by four or five statements, each requiring a "True" or "False" answer. Type 1A questions carry a weight of 5 points ($125/700 = 18\%$ of total points), Type 2A questions carry a weight of 15 points ($375/700 = 54\%$ of total points), and Type X questions carry a weight of 2 points each ($200/700 = 29\%$ of total points). The Clinical exam comprises 20 Type 1A questions with a weight of 5 points each ($100/250 = 40\%$ of total points), and 75 Type X questions with a weight of 2 points each ($150/250 = 60\%$ of total points). Sample questions from each part of the exam are included in this document. On past exams these questions discriminated well between candidates who scored in the upper and lower quartiles. Additional copies of these sample questions can be obtained by writing the American Board of Radiology, 5255 E. Williams Circle, Suite 6800, Tucson, AZ 85711. Reminder: Applications for the written examination are due September 30 of the year preceding the examination.

**PART I EXAMINATION
GENERAL PHYSICS
TYPE 1A**

1. Shortly after a tritium inhalation incident, it is found that the initial dose equivalent rate to a worker is 10 mrem/hr. The committed dose equivalent in mrem for an effective half life of ten days is _____?
 - A. 0.14
 - B. 0.24
 - C. 2.40
 - D. 3.50
 - E. 3460.00

2. Which of the following is a correct sequence of phases of the cell cycle?
 - A. M -> G1 -> S -> G2 -> M
 - B. M -> S -> G1 -> G2 -> M
 - C. M -> G2 -> S -> G1 -> M
 - D. M -> S -> G2 -> G1 -> M
 - E. M -> G1 -> G2 -> S -> M

3. A current of 2.0 μA must flow into a 100 nf capacitor for how many seconds to produce a 50 volt potential difference across the capacitor?
 - A. 1.0
 - B. 2.0
 - C. 2.5
 - D. 5.0
 - E. 25.0

4. The mass attenuation coefficient for 10 MeV photons in soft tissue is $0.022 \text{ cm}^2/\text{g}$. The probability that a 10 MeV photon will penetrate a 20 cm abdomen without interacting is _____.
- A. 0.002
 - B. 0.01
 - C. 0.44
 - D. 0.64
 - E. 0.77
5. The laser most commonly used for alignment in CT scanners and on therapy accelerators contains which of the following gases?
- A. CO_2
 - B. NO_3
 - C. Sb_2S_3
 - D. He-Ne
 - E. Argon

TYPE 2A

1. After being Compton scattered at 135° , a photon has an energy of 250 keV. The photon energy before scattering was _____ keV.
- A. 260
 - B. 290
 - C. 490
 - D. 1,520
 - E. 11,600
2. The indefinite integral of e^{-ax} is
- A. e^{-ax}
 - B. $a e^{-ax}$
 - C. $-a e^{-ax}$
 - D. $1 - (1/a) e^{-ax}$
 - E. $-(1/a) e^{-ax}$
3. A dose of 4 mCi of ^{89}Sr is used for treatment of a patient. The physical and biological half lives are 52 and 26 day respectively. What will be the activity in mCi in the patient after 52 days?
- A. 0.25
 - B. 0.5
 - C. 0.6
 - D. 1.0
 - E. 2.0

4. A ^{57}Co wipe test and a background sample are counted for 3 minutes using a well counter. Using the following information, determine the ^{57}Co activity in μCi in the wipe test sample: Data for 3 minute counts for wipe test and background samples:
- ^{57}Co sample : 1350 counts
Background: 450 counts
Well counter efficiency: 0.94 cpm/dpm
- A. 1.35×10^{-4}
B. 1.44×10^{-4}
C. 4.20×10^{-4}
D. 7.65×10^{-3}
E. 8.59×10^{-3}
5. What energy (kilojoules) is imparted to a rotating anode (0.25kg) during a two second exposure that produced a temperature of 2500°C ? (The specific heat of tungsten is $0.035\text{ kcal/kg}^\circ\text{C}$ and $1\text{ cal} = 4.186\text{ J}$).
- A. 17.9
B. 45.7
C. 87.5
D. 91.4
E. 182.9
6. What fraction of gamma rays emitted from a point source will be incident on a 100 cm^2 detector at a distance of 50 cm?
- A. 6.0×10^{-5}
B. 1.9×10^{-4}
C. 1.6×10^{-3}
D. 3.2×10^{-3}
E. 4.0×10^{-2}
7. What is the ultrasound pulse power (in mW) remaining after a 100 mW ultrasound pulse loses 30 dB while traveling through tissue?
- A. 0.03
B. 0.05
C. 0.10
D. 3.33
E. 4.48

TYPE X

Items 1-5

True statements about the focal spot in a typical diagnostic x-ray tube include which of the following?

1. It expands with increasing tube current.
2. It expands with increasing tube voltage.
3. It displays a bimodal intensity distribution.
4. It yields smaller measurements with a star test pattern than with a pinhole camera.
5. Its effective size depends on the measurement location along the cathode-anode axis.

Items 6-10

For nongrid techniques in radiography, the scatter to primary ratio will be increased for:

6. an 80-kVp beam used to image the thorax rather than the abdomen.
7. an x-ray field that covers a 35cm x 43cm film rather than a 20cm x 25cm film.
8. mammography of a firmly compressed breast rather than a breast that is not compressed.
9. a patient moved toward the tube for magnification.
10. imaging of a thick patient rather than a thin patient.

Items 11-15

Increasing the matrix size in the acquisition of images for a given field of view will usually increase the:

11. contrast resolution.
12. number of gray levels.
13. statistical fluctuation per pixel.
14. limits of spatial resolution.
15. data-storage requirements.

Items 16-20

Recombination in an ionization chamber is more likely to occur with increased:

16. LET
17. dose rate.
18. polarizing voltage.
19. electrode space.
20. gas temperature.

Items 21-24

True statements about Geiger-Mueller (G-M) survey instruments calibrated against ^{137}Cs sources include which of the following?

21. They accurately measure exposure rates associated with diagnostic x-ray units.
22. They accurately indicate the exposure rate in milliroentgen per hour for persons standing near patients with ^{137}Cs implants.
23. A reading of 0 indicates no radiation is present.
24. They detect and indicate ionizing events per unit time.

Items 25-28

True statements regarding radiation and pregnancy include which of the following?

25. About five percent of live births have "spontaneous" malformations or congenital abnormalities.
26. The NCRP recommends an equivalent dose limit of 50 mSv (5 rem) to a fetus.
27. There is a lower risk of abnormalities associated with a diagnostic dose of less than 50 mGy to the fetus than with other risks normally associated with pregnancy.
28. Growth retardation commonly occurs during the pre-implantation period.

**CLINICAL QUESTIONS
TYPE 1A**

Directions: Select the best answer from the five answer choices for each of the following items.

1. The kidneys are located:
 - A. inferior to the bladder.
 - B. above the adrenal glands.
 - C. anterior to the quadriceps muscles.
 - D. within the retroperitoneal space.
 - E. anterior to the pancreas.

2. The normal sequence of structures encountered as blood returns from the lower extremities is:
 - A. inferior vena cava, right atrium, right ventricle, pulmonary artery, pulmonary vein.
 - B. inferior vena cava, right atrium, right ventricle, pulmonary vein, pulmonary artery.
 - C. inferior vena cava, left atrium, left ventricle, aorta.
 - D. inferior vena cava, left atrium, left ventricle, pulmonary artery, pulmonary vein.
 - E. superior vena cava, right atrium, right ventricle, aorta.

3. The joining of two ends of a severed body tube is called:
 - A. an arthrosis.
 - B. an anastomosis.
 - C. an anastial ptosis.
 - D. a tubal ligation.
 - E. a canthosis.

4. The normal function of the prostate is to:
 - A. store sperm.
 - B. supply the energy for ejaculation.
 - C. control the supply of testosterone.
 - D. secrete a constituent of the seminal fluid.
 - E. secrete prostaglandin.

5. Which of the following tissues is the most radiosensitive?
 - A. CNS (brain)
 - B. Cardiac
 - C. Skeletal
 - D. Thyroid
 - E. Hemapoietic

TYPE X

Directions: Respond either true or false to each item as it relates to the preceding question or incomplete statement.

Items 6-10

Which of the following joints is a ball-and-socket joint?

6. Knee
7. Wrist
8. Elbow
9. Ankle
10. Hip

Items 11-15

The mediastinal structure includes the following:

11. Heart
12. Lymph nodes
13. Superior vena cava
14. Diaphragm
15. Esophagus

Items 16-20

Which of the following are functions of the liver?

16. Produces bile
17. Produces insulin
18. Makes white blood cells
19. Detoxifies blood
20. Controls adrenaline production

Items 21-25

Which of the following terms can be used to describe etiology?

21. Bacterial
22. Viral
23. Pathologic
24. Necrotic
25. Unknown

PART II EXAMINATION
DIAGNOSTIC RADIOLOGICAL PHYSICS
TYPE 1A

1. A fluoroscopic unit has an automatic brightness system which operates using a fixed manually selected kVp and a variable mA. For a given patient thickness, as the kVp is decreased, the mA and patient entrance exposure rate (EER) will vary in the following manner:
 - A. The mA decreases and the EER increases.
 - B. The mA increases and the EER is constant.
 - C. The mA increases and the EER increases.
 - D. The mA decreases and the EER is constant.
 - E. The mA increases and the EER decreases.

2. A fluoroscopic image using a 250 mm FOV on the image intensifier is digitized to a 512 x 512 matrix. The maximum measured horizontal resolution at the input phosphor is _____ lp/mm.
 - A. 0.5
 - B. 1
 - C. 2
 - D. 3
 - E. 4

TYPE 2A

3. A bone transmits $1/2$ as much radiation as its surroundings to a radiographic film which has an absorption coefficient of 3. When the developed film is viewed by light transmission, the ratio of the light transmitted by the bone compared to its surroundings is _____.
 - A. 2/1
 - B. 3/1
 - C. 4/1
 - D. 8/1
 - E. 12/1

4. A 1.5 T MRI system is used to obtain transverse spin-echo images with TR = 600 ms and TE = 20 ms. For edematous brain tissue with a T1 of 1 s and a T2 of 100 ms, the signal measured with this sequence is _____ percent of its maximum possible value.
 - A. 37
 - B. 45
 - C. 55
 - D. 60
 - E. 98

TYPE X

Items 1-5

In a CT scan utilizing a technique of 120 kVp, 200 mA, 1 second scan time (continuous x-ray beam), 10 mm slice thickness, the maximum surface dose for a single-slice is 1.0 cGy. Which of the following are true statements?

1. For 10 slices with a table increment of 10 mm, the maximum surface dose will be between 1.2 and 1.7 cGy.
2. For 10 slices with a 5 mm table increment, the maximum surface dose will be between 1.2 and 1.7 cGy.
3. If the slice thickness is reduced to 5 mm and the scan time is adjusted to give the same noise, the single slide dose will be between 1.2 and 1.7 cGy.
4. If the kVp is increased to 140 kVp with the mA and scan time remaining constant, the single slice dose for a 10 mm slice will be between 1.2 and 1.7 cGy.
5. If the kVp is increased to 140 kVp and the mA and the scan time are adjusted to achieve the same noise, the single slice surface dose will be between 1.2 and 1.7 cGy.

Items 6-10

The HVL is measured on a mammography unit at 30 kVp and found to be 0.28 mm of Al. The compression paddle was not in the beam. The manufacturer specifies that the source assembly contains 0.030 mm of Mo filtration and that the HVL measured in the factory under similar conditions was 0.30 mm of Al. Assuming that the unit has excellent exposure reproducibility, which of the following are possible reasons for the discrepancy?

6. "Good geometry" was not employed for the factory measurement.
7. The x-ray tube potential was not accurately calibrated upon installation and the actual tube potential was less than 30 kVp.
8. The thickness of Mo filtration is less than 0.030 mm.
9. The relative response of the chamber employed increases as the beam energy increases.
10. 1100 alloy rather than pure aluminum was employed.

PART II EXAMINATION
THERAPEUTIC RADIOLOGICAL PHYSICS
TYPE 1A

1. According to AAPM TG-21, in an electron beam calibration with a cylindrical chamber, the term P_{repl} is a
- A. gradient correction only.
 - B. fluence correction only.
 - C. stopping-power correction only.
 - D. combination of a gradient and fluence correction.
 - E. combination of a fluence correction and a stopping-power correction.
2. The increased transmission of a 4-6 MV photon beam through lung is typically _____ percent per cm of lung.
- A. 1
 - B. 3
 - C. 5
 - D. 8
 - E. 10
3. The air kerma typically used to expose "verification" type film ("V film") is _____ Gy.
- A. less than 0.1
 - B. 0.1 - 0.5
 - C. 0.5 - 1.5
 - D. 1.5 - 3.0
 - E. 3.0 - 5.0

TYPE 2A

4. The SSD output for a $10 \times 10 \text{ cm}^2$ beam on an 80 cm ^{60}Co teletherapy unit is 100 cGy per minute at d_{max} in a full-scatter phantom. The dose rate in air at the isocenter is _____ cGy per minute.
- A. 95.4
 - B. 96.6
 - C. 97.8
 - D. 101.3
 - E. 103.5
5. The exposure rate outside a primary wall of a linear accelerator is 15 mR/hr. The exposure rate at the isocenter is 400 R/min. If $W=60,000 \text{ R/wk}$, $T=1$, $U=1/4$, and $P=0.01/\text{wk}$, the shielding needs to be supplemented by _____ additional HVLs.
- A. 0
 - B. 1
 - C. 2
 - D. 3
 - E. 4

6. A calibration distance of 25 cm is recommended for brachytherapy sources. For the calibration error due to mispositioning to be no more than 2%, the maximum positioning error that can be tolerated in the source-detector distance is _____ mm.
- A. 1.0
 - B. 1.5
 - C. 2.0
 - D. 2.5
 - E. 3.0

TYPE X

Items 1-5

In a 4 MV or 6 MV linear accelerator the

- 1. magnetron, thyatron, and target are water cooled.
- 2. accelerating structure is usually filled with a high-dielectric gas.
- 3. pulse forming network can be adjusted in frequency.
- 4. thyatron supplies filament current pulses.
- 5. tuning frequency range is typically ± 100 MHz.

Items 6-10

A typical Clarkson-Cunningham "Irregular Field" calculation

- 6. assumes a point-source of radiation.
- 7. requires extrapolation of beam data to smaller-than-measured field sizes.
- 8. can be readily performed for megavoltage beams from ^{60}Co up to 18 MV.
- 9. gives accurate results in the penumbral region.
- 10. can be used to generate an off-axis isodose curve.

Items 11-15

A GM survey meter is calibrated in mR/hr using ^{137}Cs . It will be acceptably accurate for the following surveys.

- 11. ^{60}Co teletherapy head
- 12. ^{125}I brachytherapy patient room
- 13. ^{32}P injection area
- 14. x-ray contact therapy housing
- 15. simulator room shielding test with a portable x-ray machine

PART II EXAMINATION
MEDICAL NUCLEAR PHYSICS
TYPE 1A

1. In a gated blood pool study the heart rate is 60 beats/min., the LV end-diastolic count rate is 40,000 cpm, the LV end-systolic count rate is 15,000 cpm, the peripheral blood count rate per ml is 400 cpm. Assume all counts are corrected for attenuation and background. What is the stroke volume in ml?
- A. 0.625
 B. 62.5
 C. 100
 D. 400
 E. 3750
2. For a pixel size of 0.64 cm, 50% of the Nyquist frequency is _____ cm^{-1} .
- A. 0.16
 B. 0.32
 C. 0.39
 D. 0.62
 E. 0.78
3. Data taken during a NEMA extrinsic integral uniformity test include the following pixel values from a section of the 9-point smoothed scintillation camera image. Assuming that this section includes the worst image nonuniformities, what is the percent integral uniformity?

9007	9053	10059	10267
8802	8836	10019	10314
8598	8622	9928	10285
8509	8558	9718	10076
8559	8625	9472	9776

- A. 9.32
 B. 9.59
 C. 17.5
 D. 19.2
 E. 21.2

TYPE 2A

4. A low-energy pinhole collimator has a hole diameter of 2 mm and a hole-to-crystal length of 15 cm. At what hole-to-source distance in cm is the geometric collimator resolution 3.5 mm?
- A. 11.2 cm
 B. 15.0 cm
 C. 17.1 cm
 D. 26.2 cm
 E. 37.5 cm

5. Twenty cm tongs are used to remove a 100 mCi vial of Tc-99m from a lead pig and insert it into a dose calibrator. The absorbed dose to the hands is not to exceed 0.5 mrad. Calculate the maximum transfer time in seconds. (Specific gamma ray constant $T_{20} = 0.6R/mCi-hr$ at 1 cm. Assume f-factor of 1.)
- 6
 - 10
 - 12
 - 16
 - 20
6. If 85 percent of the injected activity of Tc-99m sulfur colloid is removed from the blood by the liver, what is the maximum activity in mCi that can be injected without exceeding 60 mrad to the kidneys from activity in the liver? The S factor (liv \rightarrow kid) is $3.9 E-06$ rad/uCi-hr. (Assume the biological elimination rate is negligible compared to physical decay.)
- 1.6
 - 1.7
 - 1.8
 - 2.1
 - 2.5

TYPE X

Items 1-5

True statements about MIRD dose calculation for a patient receiving a diagnostic radiopharmaceutical include which of the following?

- The MIRD result can differ from the actual patient dose by as much as a factor of two or more.
- The radionuclide decay parameters are frequently a significant source of error.
- The percentage of uncertainty in the administered activity is on the order of 5%.
- Errors in the estimation of organ mass do not affect the dose calculation for nonpenetrating radiation.
- The assumption of instantaneous uptake in organs causes the calculated cumulated activity for that organ to be larger than expected.

Items 6-10

"Off-peak high" images are useful in scintillation camera imaging and/or quality control for

- reducing the amount of scattered radiation in an image.
- improving field uniformity.
- testing for the presence of crystal hydration.
- improving field uniformity for images involving photons of two different energies.
- increasing image contrast.

Items 11-15

The Poisson distribution

- is defined only for non-negative integers.
- is symmetric about the mean.
- has two free parameters.
- is nearly equal to a Gaussian distribution when the mean is > 100 .
- is appropriate for counting both point sources and extended sources.

ANSWER KEY

PART 1 - GENERAL PHYSICS

TYPE 1A	
1	E
2	A
3	C
4	D
5	D

TYPE 2A	
1	D
2	E
3	B
4	B
5	D
6	D
7	C

TYPE X							
1	T	8	F	15	T	22	T
2	F	9	F	16	T	23	F
3	T	10	T	17	T	24	T
4	F	11	F	18	F	25	T
5	T	12	F	19	T	26	F
6	F	13	T	20	F	27	T
7	T	14	T	21	F	28	F

PART 1 - CLINICAL

TYPE 1A	
1	D
2	A
3	B
4	D
5	E

TYPE X							
6	F	11	T	16	T	21	T
7	F	12	T	17	F	22	T
8	F	13	T	18	F	23	F
9	F	14	F	19	T	24	F
10	T	15	T	20	F	25	T

PART 2 - DIAGNOSTIC RADIOLOGICAL PHYSICS

TYPE 1A	
1	C
2	B

TYPE 2A	
3	D
4	A

TYPE X							
1	T	4	T	7	T	10	T
2	F	5	F	8	T		
3	F	6	T	9	F		

PART 2 - THERAPEUTIC RADIOLOGICAL PHYSICS

TYPE 1A	
1	B
2	B
3	C

TYPE 2A	
4	C
5	A
6	D

TYPE X							
1	F	5	F	9	F	13	F
2	F	6	F	10	T	14	F
3	T	7	T	11	T	15	F
4	F	8	F	12	F		

PART 2 - MEDICAL NUCLEAR PHYSICS

TYPE 1A	
1	B
2	C
3	B

TYPE 2A	
4	A
5	C
6	D

TYPE X							
1	T	5	T	9	F	13	F
2	F	6	T	10	T	14	T
3	T	7	F	11	T	15	T
4	F	8	T	12	F		

SEP 1995

General Format

The written exam was broken into three sections. The first two given the first day and the third the second.

Part I - Clinical: This section was completely anatomy and physiology, and lasted one hour. It was a series of 100 multiple guess, and true/false. More physiology than I expected !

Part II - Physics: This section was a mixture of physics questions, with some oriented to physics of radiology and some which were pure physics from first and second year college physics. I would concentrate on studying physics relating to radiology since the other area is too broad with questions coming from out in left field. A tough exam, and lasted 3 hours.

Part III - Clinical Physics, Therapy: This section was broken into three sections. First was 25 multiple guess, the second 25 problems (require series of calculations), and the third was 100 T/F. Note that each section was worth a different amount of points, so you may want to evaluate which section to do first. The T/F went pretty fast, and the problems took some time but were worth 54% of the points. Consider your best strategy. This was a three hour exam, and seemed like a fair test of typical clinical calculations.

Due to serious brain death following the exam exact questions could rarely be recalled but I can point you in the areas which were stressed.

Part I - Clinical

1. Know the function of the following organs in addition to the major organ systems:

- »»» Thalamus
- »»» Thymus
- »»» Pituitary gland
- »»» Pineal gland

2. Look at the anatomy and function of the lungs with respect to

- »»» blood flow paths - oxygenated, de-oxygenated blood
- »»» structure - lobes (2/3)
- »»» control of respiration comes from.....

3. Know functions of the endocrine system
4. Composition of blood - sodium, potassium etc.
5. What controls serum calcium levels in the body
6. Know the blood flow path in the heart - oxygenated, de-oxygenated
7. Purpose and operation of the cell membrane.
8. What is the radiosensitive portion of the cell.
9. Joints in the knee are lubricated by????????
10. For blood volume studies, radionuclides are tagged to or infused with which of the following:
 - ⇒ erythrocytes ⇒ red blood cells
 - ⇒ plasma ⇒ lymphocytes
11. Define active transport as it relates to:
 - ⇒ I-131 therapy ⇒ TL cardiac studies
 - ⇒ Lung studies ⇒ Sr-therapy

Part II - Physics

1. Given μ , and ρ be able to calculate exponential attenuation of photons in bone or other material .
2. Given a circuit with a battery, resistor, capacitor and a switch, all in series, determine the voltage across the capacitor at a specified time after the switch is thrown.
3. Given the equation for voltage vs radius ($V_i = V_o \cdot \ln(r/a)$) of an ion chamber with a central probe radius of $a = 0.05$ cm and outer radius of 0.5 cm calculate the electric field at the central radius ($r = 0.05$) if the voltage of 130 V is applied.

9. Therapy is given with parallel opposed beams, one at 23 MV and one of 4 MV. Given percent depth dose data for each, what is the ratio of the maximum doses between the two beams. (given pat. dia.)

10. Factors which could cause depth dose data taken in a water phantom to be measured increased over actual depth dose includes which of the following:

- »»» Water temperature lower than air temperature
- »»» Setting the zero of the chamber position above the actual level of the water
- »»» Not calibrating stepping motors

11. A diagnostic radiograph is taken of patient with GYN implant. While patients anatomy is readily visible the internal structure of the colpostats are not visible. The factors which will enhance visibility are which of the following:

- »»» increase mAs
- »»» increase SSD
- »»» decrease kVp
- »»» increase SID
- »»» increase kVp

12. What determines the maximum dose rate of a Linac:

- »»» Magnetron
- »»» Target Thickness
- »»» Bending Magnet
- »»» Max Field size

13. The purpose of the dual foil in an accelerator is which of the following:

- »»» Reduce Bremsstrahlung
- »»» Filter out low energy electrons
- »»» Flatten Beam

14. A treatment calculation is performed for 100 SAD, 15 x 15 at a depth of 12 cm. The field is later modified with a block which produces a 10 x 10 field size. The blocking tray transmission is 0.96. What is the percent correction required in the machine setting. (PDD, TMR, FSF provided)

15. A treatment is calculated to provide 200 cGy at 8 cm depth for a 100 SAD Tx. What is the dose at 12 cm depth.

16. A treatment is given for a Co-60 machine at 8 cm depth. What is the TMR at 8 cm depth. (% DD and TAR tables provided)

⇒ T1 and T2 relationship to RF pulse frequency

12. The film "gamma" is the slope of the H&D curve at the point of inflection T/F

13. The latitude of a film is inversely proportional to the contrast T/F

14. Nuclear Medicine type questions, do not remember question but, questions dealing with counting statistics and dead time of counters or meters.

15. A sound is made at 3 db. If another sound is made which is 3000 times louder what db level is it?

Part II - Clinical Physics

General comments on questions:

1. Lots of shielding questions

2. Lots of regulatory questions on T/F section, be sure to look at:

- ⇒ definition of misadministration
- ⇒ requirements on brachy and HDR implants
- ⇒ requirements on shipping brachy sources

3. Look at NCRP 116

4. Calculate machine setting for parallel opposed beams, both isocentrically and SSD for 26 cm diameter patient. (machine output, TMR, PDD and field size factors provided)

5. Given above SSD calculation, now calculate machine settings at 125 SSD.

6. Given TMR calc above calculate dose to cord of patient with cord at 5 cm depth.

7. A cobalt source is installed with 2500 Ci source, what is the source strength 3 years after installation. (just know T_{1/2} of Co-60)

8. The initial dose rate for a permanent implant of I125 seeds is given in cGy/h. What is accumulated dose.

4. It was determined that an archeological sample had 5% of the C^{14} concentration of current air concentration. Given the half life of C^{14} , determine the age of the sample.
5. How much charge will be liberated by a 4 MeV photon in air $\rho = .0013 \text{ g/cm}^3$.
6. A chamber of 2 cc volume is exposed to a field of 80 kV photons, at 10 R/min. What current will be generated.
7. An image of 1025 x 1025 and 64 gray scales is to be transmitted at 1200 baud (bits/second). How long will the transmission take.
8. Translate the number 17 into binary, octal, and hexadecimal.
9. You are given a table of numbers which describe a normal distribution along with the following question. A group of patients is described by the distribution with life expectation to be a mean of 30 years with a standard deviation of 2.5%. What is the percent probability a patient will live 34 years.
10. Find the standard deviation in counting if 1200 counts are measured from a source with a background measurement of 400 counts.
11. Note differences in NaI scintillator detection vs GeI detector with regard to :
 - »»» Energy Discrimination
 - »»» Sensitivity
 - »»» Cooling required

True/False

10. The following will affect contrast of a diagnostic image.

- T/F Temperature of the developer
- T/F Fixer temperature
- T/F pH of developer

11. MRI T/F questions relating to the following topics - do not remember question:

- »»» Spin -spin relaxation time
- »»» T1 and T2 relationship to field strength

17. Three treatments are given with a 30 deg wedge on a cobalt machine. Two Tx are given with the wedge in the correct orientation, one with it reversed. What is the effective angle of the wedge.

18. Wedges for two identical energy machines, one with the maximum wedge field size much smaller than the other are the same thickness. (T/F)

19. A patient is simulated at an SSD of 102 with the film placed at SID of 140. To cut blocks properly what distance should the film be placed on the block cutter if the patient is to be treated at 110 SSD.

ABMP PART II QUESTIONS 1996 - PHILADELPHIA

1. Question on screen grid contact for radiation therapy films.
2. What detector to use for TBI with electrons dose calibration/measurements.
3. What detector to use for depth dose measurements in the region from surface to d_{max} .
4. What detector to use in stereotactic radiosurgery to verify small field uniformity.
5. ICRU definition of target volume -
does it include primary cancer as well as microscopic disease
does it include primary volume and a defined margin around it

6. What is the transmission through beam stopper-

- 0.1%
- 0.5%
- 1%

7. Occupancy factor for nurses' station located above therapy room =

8. Use factor for secondary barrier is always 1?

9. While doing ^{door} shielding calculations for 25MV X-rays, have to consider-
fast neutrons
slow neutrons
capture gammas

(K-type question)

scattered x-rays

10. If concrete is not available and door material has to be used for primary beam shielding, what can be

- used- (** place in order starting inside room and moving out*)
lead, borated polyethylene, steel
lead, borated polyethylene
lead, steel, borated polyethylene, lead

11. Five ^{Ir-192} seeds are placed 1cm apart. At a point 1cm away from the central axis, if we want 2000cGy/hr what should be the strength of each seed.

12. Permanent ^{125}I implant delivers 12000 cgy. What is the dose delivered after 4 months.

13. What is the dose rate 5cm away from a 5mCi source of ^{131}I

14. What is the most appropriate match

- 15. Cs137- 2% decay per year
- 15. Pd? - emits 400KeV gammas
- 16. Co60 - gammas emitted from Ni60 nucleus
- 17. ^{131}I - closest to 1125

18 Which radioactive material is used for bone mets - Sr^{89}

19 Typical dose for Sr^{89} administration- 4mCi

20 3D - beam aperture can be changed for each energy
beam aperture can be changed for each field

21 If there is a 5cm error in setup for 6MV xray treatments - PDD at 10cm depth changes by
10% (SSD)

5%

2%

1%

22 TBI- 2 gantry angle method is used for :
dose uniformity
reducing X-ray contamination

23 Question on multileaf collimators:
cannot be used for island type blocking
transmission in between leaves is 5 times transmission through leaves
penumbra is sharper than custom blocks

24 Shielding for intraoperative therapy- can use, assuming sterile conditions:
lead with lucite covering
lucite
cerrobend
bolus

25 Given a single 6MV beam incident on a surface- if dose at 10cm depth =200 cGy, what is dose at 5cm depth,
TAR's for d=10 and d=5 provided.

26 Isocenter for planning was placed at midpoint. Then the isocenter was moved to center of tumor which
is located more laterally.
Dose at midline increases
dose on ipsilateral side increases
dose on contralateral side increases

27 For hemibody treatment, patient field has to be split into two. Field size at 100cm SSD is given. For
186cm SSD, to match at midline, given patient thickness, find gap on skin. Field size at 100SSD is
35x35cm.

28 Question on brachytherapy- if you change from ovoid to mini ovoids-
surface dose increases/decreases

29 Wedge pair for superficial tumor planning
wedge angle $\theta = 90 - \phi/2$
distribution depends on energy used
individual wedge isodose lines should be parallel to bisector of hinge angle

30 Match: 25 MeV electron beam

31 16 MeV electron beam - 50% isodose line at approximately 7 cm depth

32 12 MeV electron beam

33 9 MeV electron beam

34 16MeV electron beam blocked down to 4x4 cm size

Rp changes
R50 changes
dmax changes

also skin dose changes

35 Match definition for : Hyperfractionation

36 Hypofractionation

37 accelerated fractionation

38 DNA repair question - *question asked "which of the following is evidence that DNA is the critical structure in cell killing by radiation?"*
(I don't remember any of the choices)

39 Stereotactic radiosurgery involves
different fields
motion of gantry
simultaneous motion of gantry and couch

40 Brachytherapy shielding question. Patient is loaded with 80mg Ra. eq. ITVL shield is used. What is dose rate at 1.5 m distance assuming shield is in between.

41 Given exposure rate and percentage attenuation of 1 lead sheet. How many sheets are needed to reduce dose rate to 5%.

42 Frequency of Compton and Photoelectric interactions will be most equally probable at what energy

83 KeV
100 KeV

43 Ratio of photon to electron current in linac is

1:10
1:100
1:1000
1:10000

44 Size of cavity in waveguide is:

2cm
3cm
5cm
10cm

↖ for 3000 MHz microwaves

45 Question on isolator/circulator

46 If inner (active) volume of Farmer chamber can be accurately known, which of the following can be eliminated-

calculation of N_{gas}
calculation of N_x
calibration at ADCL
calculation of Pion

47 Occupancy factor for outside corridor=

1
1/4
1/16

48 K_c (collision kerma) = $X/(W/e)$
 $X*(W/e)$

49 Match complications with treatment site:

- 50 proctitis
- 51 xerostomia
- 52 telangiectasia

53 MRI is used in stereotactic radiosurgery localization instead of CT because stereotactic headframe cannot be seen on CT image
CT cannot localize tumor in normal brain tissue

} this question asked for advantages of using CT, MRI, & angiography for brain tumor localization rather than CT alone

54 Question on QA for gantry isocentricity- tolerance should be within 1mm diameter sphere
2mm diameter sphere

55 Question on Co60 machine monthly QA parameters

56 Frequency of QA of : tablet digitizer

57 ----

58 ----

59 ----

60 HDR QA question- what QA should be done before each treatment.

61 HDR question- $^{10}C_i$ is stuck for 360 seconds. What is dose to the patient at 1cm distance.

62 After ^{131}I administration, nurses' thyroid uptake reads 10uCi. What was the exposure rate she was subjected to in mSv/hr.

} question gave activity, mass of thyroid, decay scheme & wanted to know dose received

63 Question on leak test lowest detection limit of detector - 5nCi

- 64 Question on parotid treatment with photons and electrons-
 - e- dose should be prescribed to midline
 - bolus should be placed on skin
 - e- field should be larger than photon field

65 Problem of dose under block

66 Co60 treatment- patient was given treatment to the wrong site for 1 out of a total of 15 treatments. This is a:
recordable event
reportable event
call the referring physician
contact the NRC by telephone

67 Average exposure around a Co60 machine that a technologist can receive is : __mR/hr

68 During chart checks, physicist's responsibilities include:
total # of Tx
total # of days of Tx
reasonable prescription dose

69 Flatness was found to be off in the gun-target plane. What could have happened:
flattening filter may have moved *or bending magnet current change*

70 Use factor for all secondary barriers=1 ?

71 Head frame for stereotactic radiosurgery is fixed to the head by:
pins through one plate of the skull
screws through one plate of the skull
screws through both the plates of the skull

72 In stereotactic radiosurgery, compared to a 4x4 cone, a 3x3 cone's output is different only by 0.2%. This
Is because:
I. Jaws are fixed in position

but the difference in collimator output is about 2% for 3x3 vs. 4x4

73 Vertebral body lies posterior to the spinal cord??

74 Question on pituitary gland irradiation

75 To match spinal AP-PA fields with brain field:
couch has to be rotated (*for brain fields*)
collimator has to be rotated (*for brain fields*)
both couch and collimator have to be rotated
junction has to be moved

(K-type question)
← I think this choice had something to do with rotating couch or collimator for PA spine fields

76 Question on location of celiac node

77 Location of __ node (in abdomen) for treatment of cervical cancer

78 AP-PA separation =38cm. Lateral separation =40cm. Beams are weighted 1:1:0.8:0.8. To deliver 180 cGy to the isocenter. TMR's for each field given. What MU's are used for each field.

79 Patient was simulated and calculated for SAD, but was treated at SSD. What is true:
dose distribution throughout the volume remains the same
volume treated at the isocenter remains the same
dmax dose changes

80 Dose escalation for the following primary diseases:
breast (intact) 5000-5500
prostate 6840-7020
seminoma 2000-2500
Hodgkins 4500

81. Which TG-21 factors are always <1.0 ?

82. Stereotactic Radiosurgery is used for which of the following diseases :

1. Arteriovenous malformations
2. Glioblastomas
- 3.
4. Audio-something (answer is all of the above)

83. Know how to convert mg. Ra. eq. To air kerma units.

84. Definition of kerma (does it include radiative losses, etc.)

85. Dose rate at 1 cm away from 10 Ci HDR source

86. What calibration factors vary with depth for electrons ?

Ans: Prepl, L/p

87. What are some of the side effects of cranio-spinal irradiation.

88. What affects TLD light output :

1. Temperature
2. Length of time after irradiation
3. Rate of heating
- 4.

89. A 6 MeV e- travels through 3 m of air. By how much is the average energy reduced?

(1/2MeV, 1 MeV, 2 MeV, etc.)

90. A woman receives I-131 treatment, then goes home. Which of the following activities should be avoided:

1. Preparing meals
2. Caring for elderly
3. Sleeping w/ husband
4. Breast feeding

91. What are some reasons for putting caps on ovoids?

92. Relation between TAR, BSF & TMR

Ans: $TAR = BSF(TMR)$

93. Question on dose volume histograms...

(in particular, something about dose bin size)

94. Why is there no bragg peak for electrons?

95. Definition of Quasi-threshold dose

1. Dose which kills 37%
2. Represented by shoulder

96. F-factor for air - know its numerical value and know what it means.

97. Which of the following needs to be accurately checked for stereotactic radiosurgery?

1. Couch lateral positioning
2. Couch vertical positioning
3. Couch longitudinal positioning
4. Couch axis of rotation coincidence with isocenter

98. Which of the following agencies have regulatory authority over radiation therapy?

1. NRC
2. FDA
3. State agencies
4. NCRP

99. For ion chamber/electrometers, what needs to be checked prior to each use

1. Leakage
2. Linearity
3. Collection efficiency
4. Voltage

100. Given separation of head and separation of body and TMR's calculate the required thickness
For a head compensator for total body photon irradiation.



WYNDHAM FRANKLIN PLAZA HOTEL

ALCOHOL SOURCE OF ^{60}Co DELAYS BY β^- DECAY. WHAT IS THE CURRENT EMITTED BY THE SOURCE [NOTE: ^{60}Co EMITS 2 PHOTONS PER DECAY].

AN X-RAY TUBE EMITS RADIATION w/ MIN WAVELENGTH OF 2 nm. WHAT IS ~~ENERGY USED TO~~ PEAK TUBE POTENTIAL.

ACCESS SPEED	C	① FLOPPY DISK
	D	② HARD DISK
STORAGE CAPACITY	A	③ OPTICAL DRIVE
	B	④ RAM

A COMPUTER CAN BE SET UP TO BOOT OFF OF ANY OF THE FOLLOWING EXCEPT
A) HARD DISK B) FLOPPY DISK C) RAM D) ROM E) MAG TAPE

RELATIVE TO A 16-BIT WORD, A 32-BIT WORD CAN ADDRESS
A) 2x B) 16x C) 65000x D) 256000x ^{AS MANY} ~~THE~~ ADDRESSES

WHAT IS THE BINART REPRESENTATION OF 125?

EXPOSURE AT FILM IS 5 mR, IF PT IS 20 cm THICK, 100 cm TO FILM & HVL TISS = 4 cm, WHAT IS ESE.

FOR GIVEN EXPOSURE, QUANTUM MOTYLE IS WORST FOR A SYSTEM w/

- A) HIGH DOE, LOW CONVERS EFFIC
- B) LOW " HIGH " "
- C) ANY " , LOW " "

~~Pos~~ @ WHICH SINGLE-HIT & MULTIPLE HIT CELL KILLING IS SAME IS: (A/B) (X/B) ETC

FOR ELECTRON ACCEL INTO A TARGET ~~Z~~, ACROSS POTENTIAL V, INTENSITY OF PROTON BEAM IS \propto TO
A) VZ B) V^2Z C) $(VZ)^2$ D) V/E E)

CLINICAL 1996

1. What is the circle of Willis?
2. Which of the following are associated with the knee? tibia, iliac artery, femur, ...
3. Questions about lung function:
 - a. What is the tidal volume?
 - b. T/F - each lung has two lobes
 - c. What is the percent of air still in lungs after exhalation?
 - d. What controls respiration?
4. An AP chest x-ray was shown and the following T/F questions asked:
 - a. Is this a lateral view?
 - b. Are the costophrenic angles easily seen?
 - c. A few anatomical structures were labeled and identification questions asked.
5. A CT slice of the male pelvis was shown and the following T/F questions asked:
 - a. Is this an MR image?
 - b. Bladder, rectum, and muscle were labeled and identification questions asked.
6. A thallium study is performed for what purposes?
7. Where is the foramen magnum located?
8. Which of the following vessels contain oxygenated blood? vena cava, iliac artery, pulmonary artery, pulmonary vein
9. Which chamber of the heart pumps blood to the lungs?
10. Which of the following are part of the endocrine system? testis, prostate, ...
11. Which conditions are treated with insulin? diabetes, hypoglycemia, ...
12. T/F statements about cerebellum:
 - a. It has hemispheres.
 - b. It controls memory.
 - c. It controls coordination
 - d. It is not present at birth.
 - e. It is connected to the brain stem.
13. Given a list of bones, which are part of the right upper extremity?
14. Given a list of anatomical structures, which belongs in the thorax?
15. Which of the following terms is associated with color? erythro, leuko, cyano, melano, chromo
16. What is a neoplasm?
17. What is the main function of the spleen? destroy red cells, destroy white cells, ...
18. T/F statements about T-cells
 - a. Called so because of association with the thymic system.
 - b. Part of the infection-fighting system.
19. What cancer is the leading cause of death of US females? cervix, breast, lung, ovary
20. What cancer is most prevalent in US males? lung, colon, prostate, ...
21. What is the major secondary disease to AIDS? KS, lymphocytic leukemia, ...
22. Which of the following diseases is most likely to cause bone mets in males? lung, prostate, brain, ...
23. Breast cancers originate in what type of tissue? glandular, adipose, connective, subcutaneous
24. Which of the following are bones? hyoid, stapes, putamen, fundus
25. Which of the following structures are in the peritoneum? stomach, fovea, ...
26. Which of the following makes the gallbladder contract? ice cream, OJ, prunes, water, bread
27. T/F statements about oxygen enhancement ratio:
 - a. Decreased for high LET.
 - b. About unity for neutrons.
 - c. Decreases for high dose rate.
 - d. ~2.5 for high dose rate photons.
28. In what phase of the cell cycle is the cell most radiosensitive?

29. Given a cell strain with $D_0 = 50$ Gy, what percent will survive 100 Gy?
30. Is the mean time for onset of radiation-induced leukemia about 20 years?
31. Something about cancer induction and thresholds.

GENERAL PHYSICS 1996

1. A diagram of an inverting op amp was shown and questions asked about it.
2. A diagram of an RC circuit with battery and switch was shown and the following questions asked:
 - a. What is the current before $t = 0$ (when the switch is thrown)?
 - b. What is the voltage through the resistor at $t = -2$ sec?
 - c. What is the voltage through the resistor at $t = 2$ sec?
 - d. What is the current at $t = 2$ sec?
3. Given a critically damped meter with time constant 4 s. Count for 6 s and get X counts. What is the true count rate?
4. T/F statements about NRC QMP:
 - a. Must have 2 forms of ID for the patient.
 - b. Techs administering 25 mCi of I-125 must be bioassayed.
 - c. Medical physicist must confirm nuclear medicine activities and dosages administered to patients.
 - d. The QMP regulations cover Cs-137 brachytherapy.
5. T/F statements about pregnant workers:
 - a. They can declare their pregnancy verbally.
 - b. They may not receive any more exposure if already have 5 mSv exposure at declaration time.
 - c. They must be badged if expect them to receive > 0.5 mSv.
 - d. They should not receive > 0.5 mSv/month.
6. Given μ or (μ/ρ) , what is percent transmission through thickness X?
7. Given an alloy that is 99% Al and 1% Cu by weight. What is the error in the HVL if use alloy instead of Al to measure HVL? Given ρ for all and (μ/ρ) for Al, Cu.
8. A patient is given 980 MBq internally. After 10 h the concentration in the blood is 120 MBq/l. 6 l blood. $t_{1/2 \text{ rad}} = 13$ h. What is $t_{1/2 \text{ biol}}$?
9. Given a beam that is half 50 keV and half 100 keV. It passes through material of thickness X, with μ 's given. What is the resultant average energy?
10. T/F questions about f_{med} :
 - a. What is the value for bone at diagnostic energies?
 - b. Is the value for bone $>$ muscle at 1 MeV?
 - c. Is the value for muscle $>$ fat at 1 MeV?
 - d. Is the value for air constant with energy?
11. T/F questions about photoelectric effect:
 - a. Dominant at 120 kVp (~ 40 keV)?
 - b. Are electrons ejected isotropically?
 - c. Can there be > 1 electron per interaction?
12. Which of the following are ejected with a continuum of energy? auger electrons, internal conversion electrons, beta rays, photoelectric electrons, bremsstrahlung
13. Given the energy decay schematic for a β^+ decay. What is the total energy loss?
14. Have decay of ^{15}O to ^{15}N . Given the masses in amu. What is the maximum energy of the beta in MeV? Did **not** give conversion factor.
15. Given a brass orifice of 0.01 m^2 area at 22°C . Given linear expansion coefficient. What is the percent change in area at 100°C ?
16. T/F statements about radon:
 - a. Use a G-M counter to measure.
 - b. If the concentration is X, some organization (NCRP?) recommends that no action is needed.
 - c. Some organization (NCRP?) recommends sealing floorboards and basement with epoxy resin.

- d. The most damage is produced by the radon daughters.
17. What is the average sea level background exposure in mSv/h?
 18. Given A , Γ , and HVL in Pb. What is the exposure rate at 50 cm behind 4 mm Pb?
 19. Given $J/\text{kg } ^\circ\text{C}$, what is the required dose to produce a 10°C rise in temperature?
 20. Given a chamber of active volume 10^{-5} m^3 and given ρ_{air} . For reading of 10 R/min, what is the current in nA?
 21. For a charged particle in vacuum, which of the following motions produces an EM field? straight with constant v , straight with constant a , circular with constant v , circular with nonconstant a .
 22. 1 byte is: 1 PC word, an ASCII character, 3 octal digits, 4 hex digits
 23. Given a $512 \times 512 \times 1$ byte image. How many bits?
 24. Something about MIPS.
 25. Optical disks are preferred over magnetic tape because: easier access, can read/write more often, ...
 26. Total of 2 questions worth of T/F statements on ultrasound in tissue:
 - a. Transverse wave.
 - b. Compression wave.
 - c. Subject to destructive interference.
 - d. Attenuation is proportional to wavelength.
 - e. Produced using a piezoelectric crystal.
 - f. Detected using a dielectric (sic).
 - g. Wavelength range is 1×10^5 to 5×10^5 Hz.
 - h. Subject to refraction.
 - i. Produces ionization.
 27. T/F statements on communications channels (no specifics given):
 - a. Have 1 or more characteristic carrier waves.
 - b. Must have a parallel channel for duplex.
 - c. Can only carry analog info.
 28. T/F statements about ^{14}C :
 - a. There is no more left on earth.
 - b. Created in atmosphere by cosmic rays.
 - c. Created in burning fossil fuel.
 - d. Created in atomic bomb tests.
 - e. Organisms select ^{14}C over ^{13}C .
 29. Given the equivalent dose to various parts of the body and the W_T values, what is the effective dose?
 30. Put $X \mu\text{Ci}$ in organ of mass Y . Eliminated with given $t_{1/2}$ effective. What is cumulative dose (but used different term) in $\mu\text{Ci}\cdot\text{h}$?
 31. A ball is thrown straight up with $v = 6 \text{ m/s}$. How long until it reaches the top of its trajectory? Given g .
 32. T/F statements about Fourier transform. Given the formula for a transform, statements were about the formulas for the coefficients and the periodicity.

NOTE: No questions on: hyperthermia, statistics, lasers.

THERAPEUTIC PHYSICS 1996

1. Given an electron beam with $E_0 = 7.1$ MeV at the surface, $E_z = 4$ MeV at 1.7 cm depth. What is R_p ?
2. Given tables of TMR values, FDD values at 100 cm SSD, and graph of output factors at 100 cm SSD, asked to calculate:
 - a. MUs for isocentric treatment to 90 cGy from each beam, given patient thickness.
 - b. Cord dose for above, given cord depth.
 - c. Error in dose if treated at 105 cm SSD by mistake.
 - d. MUs for treatment at 120 cm SSD.
3. Given tables of TAR values, FDD values at 80 cm for ^{60}Co , asked to calculate:
 - a. TMR.
 - b. Isocentric treatment.
4. For HDR, given A, Γ , P, d, T, and U. What is the shielding required? What is W in time per week?
5. T/F statements about TG-21:
 - a. For calibration of photons in polystyrene:
 - i. The SSD should be changed.
 - ii. (μ_{en}/ρ) is needed to convert to dose in water.
 - iii. Dose in poly is 1% higher than that in water.
 - iv. The detector depth should be changed.
 - b. For calibration of electrons:
 - i. A parallel-plate chamber should be put with the center of the sensitive volume at the point of interest.
 - ii. The measurement point for a cylindrical chamber should be $(2/3)r$ upstream?
6. What is the TG-40 requirement for light/radiation field coincidence per side?
7. Calculate dose to a given point from a cylinder loaded with 3 Cs-137 sources using given along-and-away tables.
8. Given a source with 1.4 cm active length. At 2 cm away and 0 cm along from the source, what is the error in dose (in terms of percent) in assuming a point source?
9. Given an irregular surface with 4 cm missing tissue, how much Al is needed to compensate? Given ρ and μ_{en}/ρ and told to neglect scatter.
10. Question on ^{89}Sr .
11. A patient is loaded with X mg.Ra.eq. Assume tissue over sources is ~ 1 HVL. What is the exposure to a nurse at 1 m?
12. Shielding calculations for linacs and sims.
13. Questions regarding the rationale behind hyperfractionation.
14. Questions about QMP.
15. T/F questions regarding ^{131}I .
16. Given P, etc., and output at a wall, how much additional shielding is required?
17. For a conservative setup, the primary barrier for sim in fluoro mode is: II assembly, film cassette, wall, ...
18. Calculate the shielding required for an office near an x-ray tube machine. Given everything (?).
19. There is a thin crack in a wall of a treatment room. A wide field meter pressed against the crack reads 1 mR/hr. Away from the crack (along the wall) the meter reads 0.5 mR/hr. The actual dose rate at the crack is: 0.5, 1, < 0.5 , between 0.5 and 1, $\gg 1$ mR/hr.
20. T/F: For survey of linac, the survey meter should be calibrated at ^{60}Co energy or above.
21. T/F questions about which of the following situations present cause for concern:
 - a. Dose rate of an uncontrolled area is 2 mR/h.
 - b. Dose rate of a controlled area is 50 mR/hr. (? not sure of the question)

22. Scatter shielding question given P, d_{sec} , d_{scat} , α , T, W. No F. Looked like a simple problem, but my answer was very different from any of theirs (several orders of magnitude).
23. For a given wall, require X inches of concrete but only have room for Y, so will make wall of concrete and steel. Given HVLs for both concrete and steel, what is the minimum thickness of steel?
24. Given TVL in Pb, how much is radiation reduced by X mm Pb?
25. Given the following diagram, T/F statements about relative doses. I forget what energy or whether energy was given.

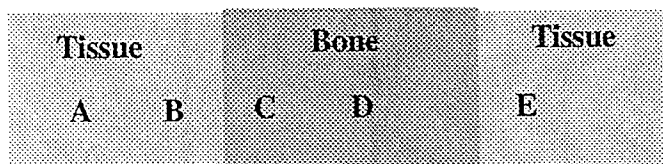

- a. Dose at B < dose at A.
 - b. Dose at C < dose at D.
 - c. Dose at E is max if E is 1.5 cm from the interface.
26. NIST calibrates brachy sources in terms of: air kerma, absolute activity, dose rate, exposure rate constant.
 27. A large-breasted patient is treated with a plastic spoiler in the beam. What is the purpose of the spoiler? increase subcutaneous dose, increase surface and subcutaneous dose simultaneously, shield electrons, ...
 28. A 30° wedged field is made up of a 60° wedged field and an open field. The central axis transmission factor is 0.25 (did not state for what!). What is the ratio of MU for wedged:open? 4:1, 2:1, 1:2, 1:4 (no 1:1)
 29. Give 50 Gy (did not state to what depth or percent depth dose) with a 16 MeV electron beam. What is the dose at 9 cm depth?
 30. What is the fraction of bremsstrahlung for an 18 MeV electron beam? 1%, 5%, 15%, ...
 31. Want to match lateral opposed fields to an anterior SCV field. Given field sizes and SSDs. What is the required table kick for the lateral field?
 32. The penumbra of a 10x10 field is 7 mm. What is the penumbra for a 30x30 field? 5 mm, 8-10 mm, >10 mm.
 33. For ^{60}Co , how far is the block tray from the patient surface? < 16 cm, 16 cm, 22 cm, ...
 34. For a linac, given output and the desired dose level beyond the jaws, how thick do the jaws need to be?
 35. For a given energy of linac, what is the primary source of radiation behind the gantry? leakage from the head, bremsstrahlung from forgotten source, scatter from the collimator, scatter from the patient.
 36. At what energy does a linac start to produce neutrons? 5 MV, 8 MV, 12 MV, ...
 37. Question about neutron dose on the central axis with respect to the photon dose. Asked for "dose equivalent", not just "dose".
 38. Questions concerning the equation for the Boag two-voltage method for determining P_{ion} .

Note: No questions on T or U values, radioactive source transport.

QUESTIONS FROM 1996 ABR BOARDS (WRITTEN)

A. GENERAL PHYSICS

1. A truck is on a bridge given weight of truck, length of bridge distance from end of bridge to truck. What is ton on bridge at one end?
2. Ball thrown in the air give time to reach peak. Given initial velocity.
3. Given batteries in series then reversed. What is current. Given initial voltage and current.
4. Given Poisson distribution problem. Formula given, data given for 3 runs. Was asked what distribution for next run would be. Ie N is now 4 not 3.
5. Had many shielding problems.
6. Almost no Ultrasound, CT, MRI, or film questions.
7. Questions on converting Bin to Hex No's and Oct to Hex etc. A couple you could use the calculator they gave you, with one you had to do longhand since it overloaded the calculator.
8. Calc. Storage required for 256 x 256 with 16 Bit matrix.
9. Had to convert to SI and back. Some questions had data in one form and answers in other.
10. Had questions on a wedge with thickness 0-10 mm. Had to determine attenuation at point under wedge.
11. Had mammo question. Surveyor used wrong Al. Filter to get HVL. How much % error would he get? Data given. Answers were 1,2,4,6,10 %.
12. Had questions using similar triangles. One I remembered had to do with the convergence point in eye and what image size would be at back of eye.

13. Question on pH in a Fe dosimeter.
14. Questions on pin hole and star devices which are more accurate, use of, etc.
15. Effect a cracked target has on an exposure.
16. Crack in wall is reading on other side of wall. Data given.

B. THERAPY :

1. Shielding questions on:
 - a. Scatter Barrier
 - b. Primary Barrier
 - c. Sim Room
 - d. C's implant
2. Dose to a point :
 - a. Nurse at her station given data, distance, source, strength etc.
 - b. Given drawing calc "B" for a wall
 - c. Dose to floor above ceiling
3. Many questions on NRC
 - a. Can they make you fire someone
 - b. Can they fine you
 - c. Can they remove someone from your license
 - d. Can they remove your license
 - e. Etc.
4. Give new FS given SFD and Pt thickness and move SSD from 100-80 with ie linac down Tx on Co.
5. Calculate collimator and table angle to match head and neck field with spine field.
6. Calculate cord dose from midline dose in SAD technique.
7. TMR from % DD or TAR

8. Calculate eq. Sq field from blocked field.
9. Do inverse sq. Calculation.
10. Questions on TG 40 & 21. Various questions, mostly concerning definitions in TG 21 and allowable variances on TG 40 ie table travel, light to ray, field size indicator etc.
11. Some T/F questions concerning neutrons.
12. Many e questions multiple choice and calculation.
13. Calculate time for Co. Tx (4 questions) various types. Ie SAD, SSD, entrance and exit dose etc.
14. Calculate Mu set for Linac. Same type as with Co. (5 questions)
15. Given a contour with missing tissue calculate isodose shift using density, e density and μ
16. How many days for Ir to decay to 95% of original activity. Must know $T_{1/2}$ Ir (not given).
17. calculate virtual SSD, data given.
18. Calculate mean free path of e.
19. Calculate E_0 and E_p .

1996 Diagnostic (Written Part)

MRI Pulse sequence, Spin Echo, shielding materials for MRI Cu, Al, Steel?

Ultrasound Pulse repetition, Fresnel range, duty factor, frequency, maximum power mW/cm², doppler angle, shift for blood flow

Sensitivity and Specificity

kVp vs exposure and increase in dose with Increase in kVp

H & D curve, Gamma gradient

Mammography magnification, ACR protocol

Exposure limits for occupational and non occupational, pregnant worker

Grids, grid ratio, bucky factor, increase in dose ?

Fluoroscopic II 6" vs 9", maximum exposure rate and regulatoru requirements for alarm

CT noise, artifacts, increase in kVp vs dose, CT dose CTDI, CT number vs attenuation, Ct contrast resolution. Ct detectors 3rd vs 4th generation scanners

Phosphoresnce and Fluorecent screen

Attenuation coefficient

Formula and all quantities for shielding calculations

NCRP #116 Dose limits

Film density vs contrast relationship

Film screen speed vs dose

Dose from AP lumbar spine vs Lat Lumbar spine procedures, dose from cervical spine, KUB, chest dose

Film processor what chemicals for developer, fixation etc., drop time

Standard deviation, noise

Focal spot measurement, slit camera, given FS size on film, what is actual FS?

ABR96DIG

General Format
ABR Written Exams in Radiological Physics
October 10,11, 1996

As usual, the written exam was broken into three parts, though the ABR considers it two parts: Part I - General Physics, consisting of a clinical portion and a general physics portion, and Part II - Speciality Physics (Diagnostic, Nuclear, and/or Therapy). Those taking all three specialties are both brave and a little nuts, but it can be done. Depending on your speciality, you may be taking Parts I and II on the same day, or on different days. For those taking both on the same day (this year it was the Nuclear people), some mental marathon training is essential. You should be prepared for brain-lock after 7-8 hours of intense concentration.

The general physics exam lasts 3 hours, the clinical exam, 1 hour, and the speciality exam, 3 hours. The 1-hour clinical exam seemed much less than 1/3 as long as the other two. Perhaps because the questions test wrote-learned material - either you know the answer or you don't. There's nothing to figure out. Everyone finished well in advance of the 1-hour, but of course, there's no going on to the general physics exam which is sitting at your feet.

The two longer exams consist of the following grouping of questions:

25 Easy Type A (18%) - Single best answer, mini problems - (ABR calls these "Easy" - ha !)

25 Hard Type A (54%) - Single best answer, multi-step problems.

100 Type X (29%) - True/False statements about a topic, grouped in fours or fives.

You're foolish if you don't do the middle group of questions first. These comprise 54% of the exam, and they seemed to take about 90 mins to complete. If you get them all right, then you can forget the other two parts! The next step should be the last 100 questions. They comprise the next greatest weight (29%), but you also feel less nervous about having an empty answer sheet since these go very quickly. Again you either know the answer right away, or you don't know it at all. The first 25 questions are worth only 18%, and I found them tougher than their weight would suggest. That's another reason to leave them to the last.

The specialty exam seemed a fair test of the practice of medical physics. Broad coverage of practical aspects of the field, and a smattering of esoteric trivia that only the very experienced or very studious medical physicist will know. The general physics exam is very broad, covering stuff as far back as freshman physics, rigid body mechanics, a little calculus, and electrical circuits. You should spend some time reviewing the basic concepts, but it's basically a physics extravaganza, so you can't possibly cover it all.

The required use of a lame, Radio-Shack EC-4045 calculator is an affront to all physicists. It's almost like requiring us to take the exam in a different language. If you feel so inclined, like I do, write a letter to Paul Capp, or whoever is the current executive director of the ABR and complain about this egregious policy. I'd prefer the use of increased time pressure to deter the use of alphanumeric/memory capabilities. Better yet, a **list** of approved calculators, including one that uses reverse polish notation. You'll find you use your calculator a lot, and that you'll waste plenty of time hunting for those everyday functions if you're not familiar with the EC-4045. You might mention in your letter that this model has been discontinued, so you can't even buy one anymore.

Part I. General Exam - Clinical Portion**SINGLE BEST ANSWER**

1. The following best describes the anatomical location of the foramen magnum:
 - A) Congenital opening in the interventricular septum
 - B) Congenital opening
 - C) Opening in the bone just inferior to the calvarium
 - D) Opening in the innominate bone medial to the acetabulum

2. The cancer whose incidence is highest in the human male population of the United States:
 - A) Brain
 - B) Colon
 - C) Skin Cancer
 - D) Prostate
 - E) Lung

3. The most radiosensitive stage of the cell cycle is:
 - A) G1
 - B) G2
 - C) S
 - D) M

4. The cancer causing the most deaths among the US female population:
 - A) Brain
 - B) Cervix
 - C) Breast
 - D) Ovarian
 - E) Lung

5. The phrase "transurethral resection" probably refers to which of the following procedures:
 - A) Curettage
 - B) Biopsy of the kidney
 - C) Prostate surgery
 - D) Urethectomy
 - E) ??

6. Almost all breast cancers arise from:
 - A) Connective tissue
 - B) Glandular tissue
 - C) Adipose tissue
 - D) Subcutaneous tissue

7. "Neoplasm" is best defined as:
 - A) Abnormal growth
 - B) Malignant lesion
 - C) Benign growth

- D) Cancer
- E)

8. The following cancer develops secondarily to AIDS:

- A) Hodgkin's disease
- B) Kaposi's Sarcoma
- C) Lymphatic leukemia
- D) Anal carcinoma
- E) Lung cancer

9. The Circle of Willis is:

- A) the circle formed by the transverse, descending and sigmoid colons
- B) the circle formed by the stomach, duodenum, and upper small bowel
- C) the pattern of blood vessels supplying blood to the brain
- D) the patten of lymph nodes in the axilla
- E) the circles under your tired eyes

10. Which of the following is most likely to cause gallbladder contraction:

- A) ice cream
- B) bread
- C) water
- D) apple
- E) asparagus

(TRUE/FALSE)

Regarding the chest x-ray shown (planar CXR shown, label A above the heart):

- 11. the trachea is displaced
- 12. the thyroid is enlarged
- 13. A is the aortic arch
- 14. the costophrenic angles are clearly visible
- 15. the image is overexposed

Regarding the image shown (transaxial CT of the pelvis shown, four labels A, B, & C near midline, D gluteus maximus):

- 16. the image is an MRI of the pelvis
- 17. A is the bladder containing a small amount of contrast
- 18. B is the uterus
- 19. C is the rectum
- 20. D is fat

The following are considered bones of normal human skeleton:

- 21. Hyoid
- 22. Stapes
- 23. Putamen
- 24. Fundus
- 25. Scapula

The following are considered part of the endocrine system:

26. Sebaceous gland
27. Prostate gland
28. Pancreas
29. Thymus
30. Salivary glands

The following word roots have a meaning related to "color":

31. erythro
32. leuko
33. melano
34. cyano
35. chromo

The peritoneal cavity contains the following:

36. liver
37. adrenal glands
38. thymus
39. iliac artery
40. spleen

The thorax contains the following:

41. portal vein
42. esophagus
43. pulmonary artery
44. pancreas
45. hypothalamus

The bones of the upper extremities include:

46. tibia
47. radius
48. humerus
49. ulna
50. fibula

The following vessels carry oxygenated blood:

51. superior vena cava
52. iliac artery
53. pulmonary artery
54. pulmonary vein
55. hypothalamus

The active growth areas in immature long bones include:

56. epiphysis
57. epiphysis
58. diaphysis
59. medullary cavity
60. cortex

Bones involved in the knee include:

61. fibula
62. ulna
63. tibia
64. radius
65. femur

Regarding the lungs:

66. consist of two lobes on either side
67. have both oxygenated and de-oxygenated blood supply
68. gas exchange occurs at the level of the bronchi
69. pulmonary vein carries oxygenated blood
70. enclosed in a fluid-filled sac

Regarding the function of the lungs:

71. Tidal volume is the volume air taken in during an average breath
72. Vital capacity is the difference between the end of expiration and maximum inspiration
73. plasma partial pressure of CO₂ critical in initiating breathing
74. lungs remain 15-35% inflated after expiration
75. expired air contains less than 10% oxygen

MATCHING

(175-177):

- A) Atomic-number difference
- B) Lag factor
- C) H & D curve
- D) Compton effect

175. Subject contrast
176. Film contrast
177. Scatter contrast degradation

1. Several questions concerning the NRC regulations. (see below)
2. Calc. dose to cord

Given

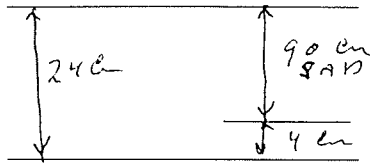

3. Many questions in TG 41.
4. Some TG 30 questions.
5. also TG?? On electrons.
6. Dose to patient on Linac x3 } Needed to interpret charts, Inv sq.
7. Dose to patient on Co. } Eq. Sq. Calc. etc.
8. All data was given when isotopes were involved i.e. T1/2, HVL, Γ factor etc.
9. TMR calculations
10. Given dose to an isodose line i.e. 200 cGy to the 105 % isodose line what is given dose for 100% to field #1.
11. Follow up to above lat field had a wedge and asked to calc given attenuation of wedge and asked to calc given dose use data from above.
12. F factor calc. given μ/ρ H₂O and muscle etc.
13. Thickness of Al needed to compensate for missing tissue. Factors given.
14. Sc and Sp calc. given TMR. Collimator open 40x40 blocked to 8x8. Calc. Mu for midline dose.
15. Neutron questions width of maze effect on scatter energy at end of maze. T-F A wider maze will give less scatter at the door than a thinner maze.
16. Given a 20 MeV neutrons and the door mounted backwards i.e. Borated poly on outside, what is the energy of the gamma coming off poly? Given choice of answers 10 KeV neutrons, 10 KeV photons, .5 MeV photons, 100 KeV photons and 10 MeV photons.
17. questions on acceptance checks for wedge factor. See below
18. In commissioning a new linac with 6 and 18 photons and electron up to 20 MeV you should determine neutron dose from which selection of beams.
 - a. Both 6 and 18 photon
 - b. 18 photon and all electrons
 - c. 18 photon and 20 electrons
 - d. 18 photon only
19. Gap calc.
20. Manard's f calculations.
21. Many brachy question all factors given Γ and T1/2 etc.
22. Calc dose from Ir after 45 days. Given Do= 8cGy hr T1/2 must convert days to hours etc.
23. Could not remember any HDR or stereo questions.
24. Many WF questions. Ie wedges from fields 90° and 220° and 180° apart, in plane cross plane diff FS, depth doses, dynamic wedge.

25. Dose outside of Rm need for additional shielding or if it meets NCRP standards. T1/4, U1/4, and W, given instantaneous dose rate. Reduce to 2 mr/hr (similar to questions on previous exam).
26. What is allowable dose to frequently exposed member of public?
27. Dose at 2 cm depth on field prescribed to 6 cm depth with cobalt 60 and 9 MeV electron, electron %DD curve given. 5Gy electron and 40 Gy at 6 cm depth with cobalt 60 no cobalt 60 data given.
28. Target angle of therapy x-ray unit greater than diagnostic unit. (T-F)
29. Target of therapy x-ray unit not transmission type (T-F).
30. Skin dose from superficial unit greater than electron. (T-F)
31. Many simulator questions, can't remember exact questions.
32. Some radio biology questions.
33. The NRC requires a wipe test on linac collimators made of depleted uranium. (T-F)
34. You can drill/screw into a depleted uranium collimator? (T-F)
35. Linac jaw are made from natural uranium? (T-F)
36. Natural uranium is commonly used as jaw material for linacs. (T-F)
37. What provides the greatest contribution to the dose from I-125 implant.
 - a. gamma rays
 - b. fluorescent photons
 - c. auger electrons
 - d. beta rays
 - e. internal conversion electrons
38. When commissioning a set of new wedges. which of the following must be measured?
 - a. wedge factor vs. Depth
 - b. wedge factor vs. Field size
 - c. wedge factor vs. Off axis
 - d. wedge factor for the average chamber reading with gantry at 0 and 180 degrees.

Can not attest to exact format on wording of questions but the idea of what they were looking for is stated. I felt it was a fair test and had many appropriate questions asked. I finished with 1/2 hour to spare. One unique screw up on exam. 2 of the 15 point questions had the correct answer marked in the text booklet, they were marked with a * .

Good Luck

ABR Written Exam Questions for AAPM SC Chapter Notebook

Advice:

Study the following:

- (1) Bushberg's Diagnostic Radiology Physics - this is the best choice (and one of the co-author's was an examiner for the orals- Seibert: If you can't use this book, then use Christiansen's Introduction to Radiological Physics all the way through including shielding and radiation Dose
 - (2) Sorensen and Phelps for chapters on Counting Statistics
 - (3) Hall for Radiobiology and especially effects of radiation
 - (4) John's and Cunningham - Chapters 1-9 and 15 (radiation protection)
 - (5) Regs- specifically NCRP 116 (not 93) for dose limits for workers and others
 - (6) Important to remember that this is closed book and that NO constants or tables are given. Several times I had to convert from rad to Gray and remember that $1 \text{ rad} = 1 \text{ cGy}$. But the problems are often given to make sure that you can manipulate the units correctly (values given in mGy or mrad and converted to Gy, etc.). There was also a problem that required the speed of sound in water and the value was not given - You HAVE TO MEMORIZE THESE!
 - (7) The format of the 97 exam was: 50 questions for the clinical part in 1 hour, but everyone finished with plenty of time; 150 questions for the general part - 25 moderate, 25 difficult and 100 T/F questions; 150 questions for the diagnostic part - 25 moderate, 25 difficult and 100 T/F. The T/F questions always went pretty fast and I think I did all 100 in less than an hour. This allows you to concentrate on the more difficult (and more weighted) questions. Some questions just appeared to be impossible or could take up a LOT of time to figure out; don't be afraid to guess and move on.
-

Hi Peter :

These are some of the questions that appeared on PART I of the ABR physics exam, which I took in 1998. I don't remember the exact questions but I recall the general topics.

Anatomy section –

1. Question on the heart ejection fraction – information about volumes of blood pumped during diastole and systole were provided.
2. T/F question on the mantle field anatomy.
3. A CT scan of the pelvis was provided and various structures were labeled for identification.
4. Question on the digestive tract and about different the different enzymes used to digest various types of food.
5. An MRI brain scan was provided and we were asked to determine whether it was T1 or T2 weighted. Several questions then followed and relied upon whether the scan was T1 or T2 weighted. This meant that if you answered the first part wrong, you would probably get all the others wrong.

The anatomy section consisted of about 100 questions and was administered before the general physics exam. The allotted time was 1.5 hr, if I remember correctly, but most everyone was done within 1 hour. This section of the exam was fairly straightforward and there appeared to be no major pitfalls.

General Physics Section –

1. Question on calculating the neutron activation in a material.
2. A circuit consisting of a resistor and an inductor was provided and two questions were asked relating to the currents and voltages at different times after opening and closing the circuit.
3. Question on calculating the rotational inertia of a disk.
4. Question on the rotational kinetic energy – question related to rotational kinematics.
5. An integral with a log function was provided and required evaluation.
6. Several questions relating to diagnostic physics, including questions on diagnostic x-ray target currents and output, shielding, etc.
7. Several questions on the linear quadratic model; graphs were provided and questions were asked relating to alpha, beta, fractionation, etc.
8. A few questions relating to the use of the equation $e^{-\mu x}$ in various materials and for various energies.
9. A nuclear medicine T/F question on well chambers and the types of radiations observed with various sources, such as Na-22.
10. A T/F question on the F-factor .
11. A T/F question on the gamma constant and various factors it is dependent on.
12. Several questions on statistics relating to the mean and standard deviation.
13. A question on counting statistics relating to counts from a detector, background counts, etc.

The general physics test consisted of 5 and 15 point questions and about 50 T/F type questions. The total no. was about 130 questions. The 5 point questions and T/F were fairly straightforward, but the 15 point questions were very challenging.

Sorry about not being able to provide more information. I will write things down right after I take part II this year.

Questions

Clinical:

Contrast-enhanced CT image of the thorax with a structure labeled with the letter A:

Answer T/F for the following:

1. A describes the Inferior Vena Cava
2. This image is at the level of T5
3. The kidney is brighter than the liver in this image
4. The rectus is anterior to the psoas

MR image of the brain provided, answer T/F for the following:

1. The white matter is brighter than the gray matter (I blew this one)
2. The brighter pixels in this image are from structures that have a high fat content

General/Diagnostic

1. Answer T/F for each of the following statements about modern CT scanners
 - 1.1. Can resolve an object of 1 mm diameter with a 1 HU difference
 - 1.2. Can perform a scan in 1 second
 - 1.3. An electron beam CT scanner can complete a scan in .1 second
2. How long does it take for an electron to travel from anode to cathode in an X-ray tube operating at 150 kV where the separation from anode to cathode is 2 mm. I think the mass of the electron was given.
3. If an administrator spends 4 hours per week in his executive bathroom and that bathroom shares a wall with an X-ray room with the following workload characteristics (several characteristics such as workload, distance to wall and exposure and shielding), what is the weekly exposure. (Note: I worked this problem through assuming that this was a Radiology Administrator and that this person might fall under the "radiation worker" category. When my calculations

didn't match ANY of the possible answers, I went back and treated the person as a member of the general public and realized that it did not say "radiology" administrator.)

Several questions about the annual dose limits, including:

4. NCRP 116 states that in a life saving procedure, the following radiation dose limit applies for diagnostic procedures (answer T/F):
 - 4.1. NCRP does not give a specific guideline for life saving procedures
 - 4.2. 4 Gy
 - 4.3. 3 Gy
 - 4.4. 5 cGy
5. Calculate the Doppler shift under the following conditions 2 MHz beam, velocity of blood is 3 mm/s and angle is 45 degrees.
6. In the general part, there were at least a couple of questions that were simple problems disguised as difficult physics problems; one was
 - 6.1. The equation for air kerma is:

which turned out to be an easy integral to solve and the answer was just the ratio of the the two definite integrals.

ABMP - 1999

- 1.) TRITIUM SPILL \Rightarrow USE OF SCINTILLATION DETECTOR WITH LINCX CRYSTAL ENCASED IN 0.25 mm ALUMINUM

- 2.) COBALT-60 UNIT. CALIBRATION ON 6/30/99 GAVE OUTPUT OF 60 cGy/min AT 80 cm SSD AT $d=5$ mm.
Pt. tx'd ON 1/1/98 @ 113 cm SSD TO $d=5$ mm WITH SAME FIELD SIZE AS CALIBRATION. TX TIME WAS 3.38 min. WHAT WAS DOSE DELIVERED?

- 3.) U/S BEAM INTENSITY OF 10^2 WATTS/cm² (INITIAL) REFLECTED; HAS 40 dB; WHAT IS REFLECTED BEAM INTENSITY (WATTS/cm²)?

- 4.) 0.26 cm³ ION CHAMBER COLLECTS CHARGE FROM 1 Gy DOSE DELIVERY. $\rho = 0.001293$ /cm³ (AIR)
HOW MUCH CHARGE COLLECTED?

- 5.) DIAGNOSTIC X-RAY Rm. $T=1$, $u=1/8$, 1° BARRIER.
 $W = 1000$ MAS-wk UNIT 2m = d FROM BARRIER
0.9 R/MAS-wk CALC. THICKNESS
0.24 mm Pb HVL OF LEAD
CONTROLLED AREA

- 6.) SINGLE HIT CELL INACTIVATION IS ASSOC. WITH _____
(a) APOPTOTIC CELL DEATH
(b) β PORTION OF THE EDN
(c) NO SHOULDER

7.) 1000 PEOPLE EXPOSED TO WHOLE BODY DOSE OF 4 Gy.
MATCH TIMES WITH ASSOCIATED OCCURRENCES

- (a) 2 DAYS
- (b) 30 DAYS
- (c) 60 DAYS
- (d) 3 YRS.
- (e) 10 YRS.

- (1) COMPLETE RECOVERY OF PLATELET COUNTS
- (2) FIRST EVIDENCE OF SOLID TUMORS
- (3) FIRST EVIDENCE OF LEUKEMIAS
- (4) PEAK INCIDENCE OF DEATH

8.) REPRESENT THE NUMBER 125 IN BINARY :

9.) WHAT METHOD CAN NOT BE USED TO STORE INFO.
FOR BOOTING OF COMPUTER

- (a) RAM
- (b) FLOPPY DISK DRIVE
- (c) HARD DRIVE
- (d) CD-ROM
- (e) READ ONLY MEMORY

10.) CHEST X-RAY AT 120 KVP VERSUS 80 KVP :

PATIENT DOSE
CONTRAST
TIME OF EXPOSURE
PHOTODE⁻ ↓ MAKING RIBS LESS VISIBLE AS SHADOW.

ii.) COUNTING STATISTICS

N_i	$(N_i - N_{avg})^2$
386	
394	
408	
404	
398	
402	
390	
397	
401	

$$\sum N_i = \# \quad \sum (N_i - N_{avg})^2 = \#$$

CALCULATE σ ?

IS THE CALCULATED σ REPRESENTATIVE OF A COUNTER THAT IS FUNCTIONING AS EXPECTED? WHAT TYPE OF TEST IS THIS?

12.)
THYROID UPTAKE

COUNTS OF SAMPLE = 3200 WITH BACKGROUND COUNTS OF 700 COUNTS. (I-131) IF PHANTOM HAS 25% OF ACTIVITY IN FT. STUDY AND HAS COUNTS OF 3000 WITH SAME BACKGROUND WHAT IS THE % UPTAKE BY THYROID?

20.) THRESHOLD FOR PHOTONUCLEAR DISINTEGRATION

21.) GENETICALLY SIGNIFICANT DOSE (GSD)

22.) SHIELDING FOR NEUTRONS BECOMES A NECESSITY FOR PHOTON ENERGIES ABOVE --- MV , ~~(10 MV)~~

23.) CARRIER-FREE SPECIFIC ACTIVITY (CFSA) IS HIGHEST FOR
(a) SHORT $T_{1/2}$, LONG $T_{1/2}$
(b) HIGH / LOW AT.#

24.) ENERGY OF AUGER ELECTRON FOLLOWING $K\alpha$ TRANSITION

25.) MAMMOGRAPHY UNIT: USES 25 KVP X-RAYS WITH A MOLYBDENUM TARGET HAVING K EDGE OF 20 KEV IF MOLYBDENUM FILTER IS USED IN CONJUNCTION YOU WOULD EXPECT

- (a) STRONG ATTENUATION $\text{MO-CHARACTERISTIC X-RAYS}$
(b) STRONG TRANSMISSION $\text{MO-CHARACTERISTIC X-RAYS}$.

26.) MAXIMUM 90° SCATTERED RADIATION FROM $0.6 \text{ MV} \rightarrow$ ^{MAXIMUM} ENERGY

27.) ABSOLUTE DOSIMETRY INCLUDES USAGE OF ---

28.) PET VS. SPECT

ABR CLINICAL Part I - 1999

- 1) SWAN-GANZTM CATHETER IS USED FOR
- 2) MOST NUTRIENTS ARE ABSORBED IN THE:
- 3) THE ORDER OF BLOOD FLOW THROUGH HEART IS:
- 4) OXYGEN ENTERS THE BLOODSTREAM IN THE LUNGS VIA (OSMOSIS, DIFFUSION, ACTIVE TRANSPORT)
- 5) BONES OF THE FOREARM INCLUDE:
- 6) HEART CHAMBER HAS AN EJECTION FRACTION OF 85%. IF 36cm^3 OF BLOOD VOL. IS PRESENT AT THE END OF SYSTOL., HOW MUCH VOL. IS LEFT AT END OF DIASTOL.?
- 7) WHICH MINERAL IS BROUGHT INTO THE NERVE CELL AXON VIA ACTIVE TRANSPORT
- 8) A PERSON WHO IS SUFFERING FROM DEHYDRATION AND A LOSS OF ELECTROLYTES FROM DIARRHEA IS MOST LIKELY TO BE DEFICIENT IN WHAT MINERAL
- 9) A PERSON SUFFERING FROM A TRIMALLEOLAR FRACTURE IS SUFFERING FROM A BREAK AT WHAT JOINT?
- 10) THE TOP OF THE ILLAC CREST IS ALIGNED WITH WHAT PROMINENT FEATURE (T12-L1, L4-L5, etc)
- 11) THE FUNCTION OF THE SPLEEN IS TO:
- 12) WHICH LYMPH NODES ARE FREQUENTLY REMOVED FOR BIOPSY WITH A MASTECTOMY

13.) THE MAGNUM FORAMEN IS AN OPENING IN WHAT BONY STRUCTURE?

14.) THE LIVER RECEIVES MOST OF ITS BLOOD SUPPLY FROM WHICH ARTERY?

15.) WHAT FOOD IS MOST LIKELY TO MAKE THE GALL BLADDER CONTRACT (ALCOHOL, ORANGE JUICE, CREAM, PRUNE JUICE, WATER)

16.) THE FUNCTION OF THE GALLBLADDER IS TO:

17.) POINTING TO AN INCORRECTLY LABELLED STRUCTURE ON A DIAGNOSTIC CHEST FILM.

18.) A PA PROJECTION INSTEAD OF AN AP PROJECTION IS PREFERRED AS A DIAGNOSTIC EVALUATION FOR SCOLIOSIS BECAUSE:

19.) THE FUNCTION OF THE LIVER IS TO:

18.) POINTING TO AN INCORRECTLY LABELLED STRUCTURE ON A SAGITALLY RECONSTRUCTED DIAGNOSTIC IMAGE.

19.) WHAT TYPE OF LASER USED MOST OFTEN TO REMOVE SKIN TATTOOS?

20.) A VITAMIN C DEFICIENCY IS ASSOCIATED WITH WHAT CONDITION?

21.) THERE ARE _____ CRANIAL NERVES (#).

22.) PORTAL HYPERTENSION IS _____

23.) CLOT WHICH MOVES THROUGH THE BLOODSTREAM IS KNOWN AS A _____.

24.) THE LUNGS CONSIST OF _____ LOBES.

25.) THE MALE CHROMOSOMES ARE DENOTES AS _____ (XY)

26.) CUBATED EPITHELIUM IS LOCATED IN THE LINING OF THE
(a) ESOPHAGUS (c) SMALL INTESTINES
(b) _____

ABR GENERAL PART I

- 1.) WHAT IS THE HEXADECIMAL NUMBER REPRESENTING THE BINARY NUMBER 1011100011?
- 2.) A PARTICLE WILL NOT RADIATE EM RADIATION UNDER WHAT CONDITIONS?
- 3.) WHAT DISK SPACE DOES A 512 x 512 PIXEL ARRANGEMENT WITH 12 BITS PER PIXEL OCCUPY?
- 4.) A 2T MRI UNIT HAS AN ASSOCIATED INHOMOGENEITY OF 100 PPM. WHAT IS THE FREQUENCY ASSOCIATED WITH THIS INHOMOGENEITY?

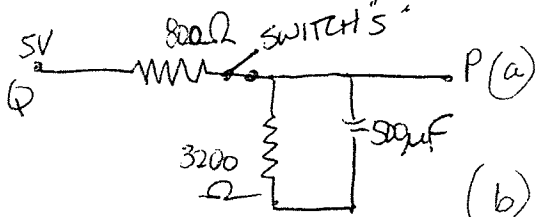
5.)  (a) WHEN SWITCH "S" IS CLOSED WHAT IS THE READING AT TEST POINT P?
(b) WHEN SWITCH "S" IS OPENED, WHAT IS THE RC TIME CONSTANT?

- 6.) A 100 μ Ci TRACER IS INJECTED INTO THE BLOODSTREAM ($T_{1/2} = 12$ hrs) AFTER 13 HOURS THE CONCENTRATION OF THE TRACER IN THE BLOODSTREAM IS 4 μ Ci/L. ASSUMING A TOTAL BLOOD VOLUME OF 6 L, WHAT IS THE BIOLOGICAL HALF LIFE OF THE RADIOISOTOPE?
- 7.) A 2 MHz ULTRASOUND BEAM ~~WAS~~ IS ATTENUATED 20 dB IN TISSUE AT DEPTH. WHAT IS THE EXPECTED ATTENUATION AT THE SAME DEPTH FOR A 4 MHz U/S BEAM?

8.) A DETECTOR (SURFACE AREA 0.001 m^2) IS 5m FROM A 25 mCi SOURCE, CALCULATE THE NUMBER OF PARTICLES IMPINGING THE ~~DETECTOR~~ DETECTOR PER SECOND.

9.) A CAMERA FOCUSES ON A DISTANT OBJECT WHEN THE FILM IS 5cm FROM THE LENS. WHAT IS THE FOCAL LENGTH OF THE LENS?

10.) TWO RADIOISOTOPES A AND B ARE COUNTED FOR 10 MIN. EACH FOR TWO DIFFERENT WINDOW SETTINGS. (BOTH A AND B SAMPLES ARE 400 mCi EACH)

	(cpm) WINDOW A	(cpm) WINDOW B
A	30,000	5,000
B	30,000	50,000
SAMPLE	60,000	60,000

HOW MANY mCi OF RADIONUCLIDE B ARE IN THE SAMPLE?

11.) NORMAL BACKGROUND READINGS AT SEA LEVEL — mSv .

12.) PROBABILITY DISTRIBUTION $P(N, m) = \frac{m^N e^{-m}}{N!}$

WHERE $N \equiv$ THE MEAN OF SOME LARGE ~~MEASUREMENTS~~ NUMBER OF MEASUREMENT.
AND $m =$ AN OBSERVATION

IF THE MEAN OF A LARGE # OF MEASUREMENTS IS 10. WHAT IS THE PROBABILITY OF OBSERVING A SINGLE MEASUREMENT OF 3?

13.) A 5m LONG BEAM HAS A FORCE OF 20kN LOCATED 2m FROM ONE END OF THE BEAM. EACH END OF THE BEAM IS SUPPORTED BY A POST. WHAT IS THE FORCE EXERTED BY THE POST CLOSEST TO THE FORCE ON THE BEAM?

ABMP Radiation Therapy Part II (Chicago 2000)

The exam contained 151 questions broken into 3 sections. There were the familiar K-type along with a section of matching and best choice. The K-type comprised almost 50% of the exam. The total exam time was 4 hours.

I can't recall enough of the answers to include them but be sure to understand the full concept of each question. They tend to give you the obvious answers but throw in some little known facts to see if you have a clear understanding.

Make sure that you read all the reports such as TG-43, 40, 21 and 25 along with appropriate reports. Also be sure to know rules of thumb. The vast majority of questions work off of those two areas.

1. What % transmission for a primary beam stopper?
2. If the original isocenter is placed at midline and then moved laterally to the center of the target volume, what would happen to the dose?
3. Limit of leak tests?
4. What would cause a significant change in dose rate of a linac?
5. What are table requirements for stereotactic radiosurgery?
6. Question regarding x-ray production in a simulator.
7. Question regarding port films and how are they best done.
8. What factors are needed to determine the size of a tumor? (TSD , TFD etc....)
9. For a 5 cm error in setup what is the % change in PDD?
10. Changing an SAD setup to an SSD. What happens/changes?
11. TD 5/5 of kidney and liver.
12. Why was NIST 99/TG-43 implemented?
13. Clarkson question on necessary info to account for blocked field.
14. Kerma as related to absorbed dose.
15. simulator vs. linac checks as required by TG-40.

16. Average E of photonuclear particles in a linac.
17. HVL calculation with lead and concrete.
18. If a chamber in a water phantom goes 5mm deeper on one side of the CAX, what would change in the measurements?
19. IMRT question on required to input to do a plan.
20. Question on pituitary radiation. Know dose to critical structures.
21. Know order of escalating doses for prostate, kidney, breast and seminoma
22. Why is there no Bragg peak for electrons?
23. Relationship for TAR, BSF and TMR
24. If PDD = ? then TMR = ?
25. If you had an 18x and 18e- for a paratoid, how would you weight them?
26. Abut fields for electrons and photons. What happens to dose distribution?
27. Know properties of a GM detector.
28. Minimum thickness of cerrobend for a 22e- beam?
29. Factor of degradation of incident photon energy to scattered.
30. Most common late effects of hodgkins?
31. What should you do to reduce dose to contra lateral breast?
32. Bragg-Gray cavity theory and what it represents.
33. CT vs. MRI. Why do we use them both and not just MRI.
34. How would you measure dose profiles for stereotactic?
35. Door shielding question with regards to what is needed from the inside of the door to the outside.
36. In a mantle field, what would receive the highest dose. (celiac, axilla etc.....)
37. What are the daily requirements for I/O devices in treatment planning?

38. matching question with exposure rate constant, inverse square, 8.25 and .876.
39. How would you boost cervical nodes after reaching cord tolerance?
40. Dose calculation for 4 field pelvis given TMR and depths.
41. TBI calculation. What is the dose to ankle given info at midline and ankle with an OAF.
42. gap calculation with all relevant information given. (just know the formula)
43. NRC regulations after changing the source on a teletherapy unit requires?
44. Know the use/occupancy factors. A group of matching questions consisted of factors for secondary radiation, primary radiation, office above the room and outside areas where traffic and pedestrians might walk.
45. Compensator calculation. Given thicknesses of the head and midline along with TMRs and compensator transmission factor calc the number of compensators needed.
46. Question regarding BSF. Know all the properties.
47. Know PTV, CTV and GTV. Question regarding relative size of each.
48. Question on MLC. Know general pros and cons.
49. HDR emergency procedures for when a source doesn't retract.
50. Why do you use caps on ovoids?
51. What happens to an electron beam when it is collimated down from a 10x10 to a 4x4?
52. Ratio of photon to electron current linac.
53. What checks to make quarterly on an HDR unit.
54. Average exposure around a Co-60 head that a therapist can receive.
55. What are a physicist's responsibilities when checking charts? (TG-40)
56. If flatness is found off in the cross plane, what might have happened?
57. How do you match spinal field with brain fields for craniospinal irradiation?
58. Be able to convert mg-Ra-eq to air kerma units.

59. Calc of dose rate at a given distance from an HDR source.
60. What affects TLD light output?
61. Question on what can be determined from a DVH.
62. What should be checked prior to use for electrometers/ion chambers?
63. NRC requires the output for one set of measurements to be done how often?
64. The chamber used annual calibrations should be calibrated how often?
65. Question on arc therapy with electrons and what happens?
66. Dose calc on arc therapy with photons. (just be able to average TMRs)
67. Be able to calc the MU/deg factor for an arc of a certain angle.
68. Properties of PDD?
69. Calculation of distance that an electron can penetrate with a certain amount of lung in the field.
70. What would you use to measure the profile of a dynamic wedge?
71. electron beam matching, know the rules of thumb and % bremsstrahlung.
71. TG-43 matching of dose rate constant, anisotropy factor and geometry factor.

TEST: ABR Therapeutic Physics Exam

TEST DATE: September 2000

TEST FORMAT: 75 multiple choice questions to be answered in about 3 hours
The first 50 questions were "easy" and worth 1 point each.
The last 25 questions were "hard" and worth 3 points each.

Easy-type questions

(1 point each)

- (1) Given a picture of non-wedged profile scans obtained using a scanning water tank, questioned asked what was wrong with the superficial-most profile (which appeared somewhat wavy in comparison to the others).
- (2) One question regarding the spatial resolution of MOSFET detectors. Possible answers were in units of μm .
- (3) Define wedge angle.
- (4) State which measuring device would be most appropriate for simulator shielding measurements for a radiation protection survey. Possible answers included different types of survey instruments (e.g., G-M tube, hand-held ion chamber) as well as different sizes of ion chambers (e.g., 1 cc, 10 cc, or 100 cc).
- (5) How much dose is delivered from I-125 after 45 days given its half-life and initial dose rate?
- (6) One question about reasons for using a parallel-plate chamber for measuring output of a 4 MV photon beam.
- (7) What is the NRC-required frequency of sealed source inventory?
- (8) One question related to a skyshine shielding calculation where person only needed to recall the formula for computing steradians given a diameter subtended and distance from source.
- (9) How much does a linac's workload increase for a TBI given the treatment distance, rep rate at isocenter, and dose to be delivered to the patient per week.
- (10) Most probable use for a 9" "rem counter" (as described by Kahn on page 495 of 1994 ed of *The Physics of Radiation Therapy*). Question was about what this instrument was used to detect. Possible answers included photons, thermal neutrons, fast neutrons, combinations of neutrons and photons, etc.

- (11) Question on ICRU Report 50 diagram outlining the GTV, CTV, PTV, TV, & IV. Person was given an illustration of this diagram and asked to which volume the arrow was pointing. (For this exam it was pointing to the PTV.)
- (12) One question about the uses and limitations of LiF TLD detectors for use in a radiation therapy department. Specifically, their accuracy, linearity, etc.
- (13) One question about what is not modeled for a beam for a 3-D treatment planning computer. Possible answers included upper collimator jaws, lower collimator jaws, target, monitor chambers, or the mirror. (Answer: mirror since the beam does not pass through the mirror, and it does not act as a beam modifier.)
- (14) What's the TG-34 recommended dose limit to a pacemaker? (200 cGy)
- (15) What's the dose to a kidney that will cause irreparable damage?
- (16) One question on use of bubble-type neutron detectors.
- (17) Which of the following can occur that does not require a full re-calibration of all beams and beam scanning for a linac? (possible answers: changing klystron, bending magnet replacement, MU chamber replacement, target replacement, or waveguide replacement)
- (18) Simple inhomogeneity calculations for photons. You're given physical densities, electron densities, and mass attenuation coefficients.
- (19) About 5 or 6 questions on TG-51.
- (20) One TG-56 question about coefficient of variation of measured seed strength before you should notify the company of any discrepancies.

Other things to note: Both old and most recent units used throughout for brachytherapy and radiation protection problems. Expect to have to convert units.

Hard-type questions

(3 points each)

- (1) Several inhomogeneity calculations for electrons and photons were asked. Usually given physical densities, electron densities, and mass attenuation coefficients. These were a little tougher than the one or two given in the easy-type questions, requiring one to perform more steps or to solve using a slightly different method to arrive at the answer requested.

- (2) A couple of questions using %DD and dose calculations for superficial units.
- (3) Given the following tangential setup and measurements, what must be the LPO gantry angle. Although not stated, one must assume IEC gantry angle convention and directly opposed beams (at my workplace, we usually make our posterior borders coplanar instead of being directly opposed by 180°). Also, the field size was given. The axis drawn on the diagram did not indicate if it was the central axis or the posterior border of the field. I assumed it was the central axis since there was somewhat of an isocenter dot drawn on the diagram.

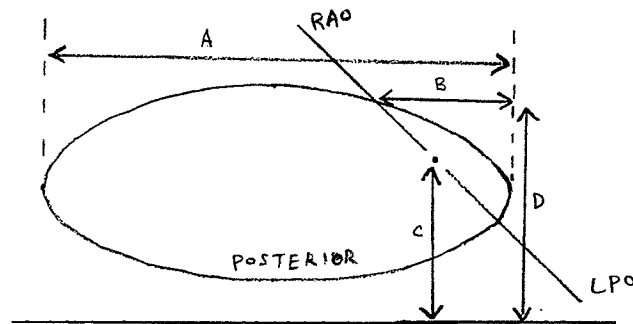

- (4) Given T/O set-up with a single 15 mgRaeq source in one ovoid, what's the dose to a point off the axis of the tandem and superior to the flange. This arrangement was placed on a grid to give one the distances needed to perform the calculation.
- (5) A mixed beam was used to deliver a particular dose to 3 cm depth in tissue. The beams used were the 9 MeV electron beam and the 6 MV photon beam. The %DD and surface doses were given in a table for both beams. The requested total dose was 55 Gy to 3 cm depth and 40 Gy to the skin's surface. What would be the d_{max} dose for each beam? (I had to set up a system of 2 equations and 2 unknowns to arrive at one of the possible solutions.)
- (6) Several basic dosimetry questions requiring one to calculate MU to be delivered using %DD and TAR tables for a 6 MV photon beam and a Co-60 unit, including one at an extended distance.
- (7) Some legitimate, clinically relevant questions on make-up doses for mistreated patients. The setups included wedges, parallel-opposed beams with and without wedges, switching of MU in calculations, calculating to wrong isodose line, etc. The dose given to a particular isodose line had to be determined based on the dosimetric error(s) made, and the correct # of MU had to be calculated for a particular field to finish the treatment in so many fractions. (This is a typical, easy problem for any clinical physicist, but can require a couple minutes longer than other "hard" problems.)

- (8) Had to determine if a linac output check was a certain percentage high or low, or exactly right. The necessary calibration information was given (e.g., temperature, pressure, electrometer reading, electrometer calibration factor, chamber calibration factor, stopping power ratio, etc).
- (9) Had to determine if measured activity of an HDR source agreed with its certificate value. Had to convert units and decay certificate source activity. Measurement was done in air and 1 meter from source. You were given a calibration factor of the instrument used to make the measurement. The question wanted to know if measured value was equal to decayed certificate activity, or a certain percentage high or low.
- (10) Several shielding questions were asked.

One dealt with a maze-less high-energy linac room, and wanted to know what material would be used to patch a small opening near the door. Possible solutions included lead, steel, aluminum, borated polyethylene, etc.

One question dealt with a treatment room for a patient being treated with about 150 mCi of Cs-137. Assuming 50% attenuation by the patient and the nearest wall was 2.5 meters away, how many extra HVLs were needed to reduce the exposure level to meet NRC regulations for the occupied adjacent room? The exposure rate constant was provided, but its units were incorrect. The exam gave $3.26 \text{ R cm}^2/\text{Ci hr}$ instead of $3.26 \text{ R cm}^2/\text{mCi hr}$. All answers were ≥ 1 HVL.

Other shielding questions which required one to calculate μ using the provided TVL, and then determine the correct # of HVLs needed to reduce the exposure level to a requested level, or a level dictated by conventional (NRC) shielding requirements.

ABR Board Exam - Part 1 - September 2000

A new exam format was introduced this year. The general physics exam remains 3 hours in length, but it now consists of 75 multiple choice questions. The first 50 questions were worth 1 point apiece, and the final 25 questions were each worth 3 points. A one-hour clinical exam followed immediately after the general physics exam. This exam consisted of 50 multiple-choice questions.

I was able to complete the general physics exam with about thirty minutes to spare. In general, I am not a fast test taker. The clinical portion went rather quickly. I finished in about 25 minutes.

The ABR provided a Casio fx-280 calculator for the exam.

In terms of preparation, the questions in this study guide are enormously helpful. This is particularly true for the clinical portion of the exam. The clinical portion of the exam covers such a broad range of topics that it is difficult to prepare for. At least half of the clinical questions were the same as or very similar to the questions in this study guide and/or the sample questions on the ABR web-site.

I would caution against putting too much faith in the information provided on the ABR's web-site. The web site outlined a test format of 150 questions (25 "easy" multiple choice, 25 "hard" multiple choice, and 100 true false). This was not the format of the exam. The web-site also stated that an examinee must pass all portions of part 1 of the exam before part 2 can be taken. I found out too late that this is not true. Many of the people at the exam were sitting for both parts 1 and 2. This misinformation is frustrating. I would suggest calling the ABR to get the answers to any questions that you might have.

One text that was very helpful was Sorenson's and Phelp's Physics in Nuclear Medicine (particularly the chapter on counting statistics). Also, Hall's Radiobiology for the Radiologist is of key importance.

Good luck on the test.

ABR 2000 – Part 1 - Clinical

1. Irradiation during which period of pregnancy leads to the highest probability of congenital deformities?
 - a. 0-10 days
 - b. 10-18 days
 - c. 18-45 days
 - d. third trimester
2. A whole body dose of 1 Gy is most likely to result in?
 - a. reduced platelet count
 - b. diarrhea
3. Which of the following lubricates joints?
 - a. synovial fluid
 - b.
4. Which organ controls blood sugar?
5. A nuclear medicine study of the brain would look at which of the following?
 - a. glucose metabolism
6. What is the best technique for imaging multiple sclerosis? (MRI)
7. CT slice is shown, which of the following is not true?
 - a. A is the spinal cord
 - b. B is the aorta
 - c. C is the liver
 - d. D is a kidney
 - e. E is the psoas major
8. Where would a glomerulus be found? (kidneys)
9. The first site of spread of breast cancer is most likely to be?
 - a. axillary nodes
10. The term metastatic means?
11. A metastatic neoplasm that has not spread beyond its initial location is called? (in situ?)
12. Blood flowing into the left ventricle passes through which valve? (bicuspid)
13. Which part of the eye is most radiosensitive?
 - a. lens
 - b. retina

- c. cones
- d. rods

14. A loss of equilibrium is most likely associated with which of the following?

- a. brain stem
- b. cerebellum
- c. frontal lobe
- d. occipital lobe
- e. cerebellum

15. Most nutrients are absorbed where?

- a. duodenum
- b. colon
- c. rectum
- d. ileum

16. The liver has how many main lobes?

17. Which of the following is not a bone of the upper extremities? (patellar)

18. The most radiosensitive stage of the cell cycle is?

- a. G0
- b. G1
- c. G2
- d. M
- e. S

19. Breast cancer is most commonly seen in which quadrant of the breast?

- a. upper inner
- b. upper outer
- c. lower inner
- d. lower outer

20. A MRI of the brain is shown. Which is not true?

- a. vitreous humor is bright
- b. bone is bright
- c. gray matter is bright

21. Where is the hilus located?

22. Which of the following vessels contains the most oxygenated blood?

- a. pulmonary artery
- b. pulmonary vein
- c. aorta

23. The barium in a barium enema serves what purpose? (contrast)

24. The Buccal Cavity is another name for? (the mouth)
25. A worker receives 10mSv per year every year? According to the BIER V report his increased lifetime risk of cancer is?
26. Which of the following detectors is the best for energy resolution?
- Geiger
 - NaI
27. The joining of two ends of a severed body tube is called:
- an arthrosis.
 - an anastomosis.
 - an anastial ptosis.
 - a tubal ligation.
 - a canthosis.
28. The normal function of the prostate is to:
- store sperm.
 - supply the energy for ejaculation.
 - control the supply of testosterone.
 - secrete a constituent of the seminal fluid.
 - secrete prostaglandin.
29. What procedure would be used to image kidney stones?
- MRI
 - CT
 - IUP
30. At what skin dose is erythema first seen?
31. Which of the following skin reaction is seen at the lowest dose?
32. How many thoracic vertebrae are there?
33. Where are the islets of langerhans are located?
34. Where is cerebrospinal fluid produced?
35. Breast cancer arises in this type of tissue:
- adipose
 - ductal
36. EEG electrodes are used to measure? (electrical impulses in the brain)

ABR 2000 - Part 1 - Physics

1. Calculate the kerma deposited by a beam with a photon flux of X and the following values for μ/ρ μ_{tr}/ρ .
2. Which of the following do not influence the MTF of film?
3. The threshold of hearing is X W/m^2 . A sound of Y W/m^2 corresponds to how many dB?
4. Electron capture competes with which of the following processes?
5. Decay scheme is shown. Not all of the energies are labeled. You are asked to deduce total energy of the decay. The key here is to simply know the threshold energy of Beta plus decay.
6. What is natural background per year at sea level **including** radon?
7. A 16 bit computer can access how many locations?
8. One hexadecimal digit can be used to count up to what number?
9. Which of the following would have the highest LET?
10. Question on Blackbody radiation.
11. Which of the following lasers is not useful for fiber optic transmission? A series of laser types were listed along with the corresponding wavelength.
12. If 0.1 kg of water is cooled from 40C to -80C, how much energy is lost? Given specific heat of water, specific heat of ice, and an additional constant (thermal fusion constant?).
13. According to the uncertainty principle which of the following cannot be measured simultaneously.
14. The area of a copper plate is 0.1 m^2 . The coefficient of linear expansion is provided. If the temperature increases from 22C to 100C, what is the new area?
15. If the workload of a machine doubles, by how much must the barrier thickness be increased?
 - a. one half value layer
16. How long can one spend 50cm from a patient with a 60mg radium equivalent implant, and not exceed the occupational limit applied to one week?

17. Counting statistics. The gross count for 10 minutes was 10000 counts. The background count for 30 minutes was 19200 counts. What is the net count rate and its standard deviation?
18. Given the area of a detector and its distance from the source. What is the detector efficiency?
19. Assume a binomial distribution. 4 measurements are taken with a maximum deviation between 2 of 10%. What is the standard deviation?
20. Question on the f-stop of a camera.
21. Given attenuation coefficient. What percentage of the incident photons is absorbed between a depth of 1 and 2 cm?
22. What is the increase in the total equivalent dose for an AP versus a PA radiograph? The dose to each organ (breast, thyroid, lung, and heart) is provided along with w_T for each.
23. A nonparalyzable records 450 cpm. It has a deadtime of x . What is the true count rate?
24. $D_q = 0.5$ Gy. 2Gy is required to reduce the surviving fraction to 0.53. What is the surviving fraction if 30Gy are delivered?
25. A-bomb survival data is provided. What is the increase in relative risk for cancer for those who received greater than 0.1 Gy?
26. For a certain diagnostic test, you are provided with the number of true positives, true negatives, false positives, and false negatives. You are asked to determine the sensitivity of the test.
27. Effective half-life problem.
28. Doppler effect. Given velocity of train, calculate frequency of a sound measured by a stationary observer.
29. $1e15$ bytes is a: petabyte, terabyte, gigabyte...
30. question involving rms voltage

ABMP part II (July 2000)
Chicago

- ◆ Similar questions to those listed in this book for ABMP 1999, part II. Also:
- ◆ Define brachytherapy functions, g , F , Λ
- ◆ Prescribed doses in TBI w/ photon and electron
- ◆ Prescribed doses in SPS, SRT, breast, prostate, seminoma
- ◆ 3-field treatment, 180cGy, gantry 120deg apart, equally weighted, lateral beams pass through 6cm lung, what dose actually absorbed?
- ◆ Particle accelerators can accelerate positive ions, neg ions, particles with neutral charge
- ◆ Ir-192 transportation: Dept. of transportation oversees it? Transportation index must match exposure rate? Only sample batches need leakage testing? Activity of Ir-192 must be indicated outside the box?
- ◆ 6x, 100cm SSD, $d=10$ cm, $PDD=.73$. Same beam used for SAD. What's TMR @ $d=10$ cm?
- ◆ Brachytherapy definitions: anisotropy / geometry / radial functions
- ◆ Use of re-entrant ion chamber in brachytherapy source calibration
- ◆ Earlier NIST shortcoming in anisotropy function calculation of I-125 due to neglecting what?
- ◆ MPD per hr, per year, next to a linac, during Co-60 operation (on and off)
- ◆ A feature in monthly QA of film (when using Co-60?) that's not used in Linac QA

Good luck !

ABMP 2001 - Therapy physics (part II)

Note: topics identified as "matching" had 3 to 4 questions a piece

BASIC RADIATION PHYSICS

Given 200 cGy delivered to volume of tissue: different for photons vs. e-? depend on energy? depend on tissue?

Compton interactions - energy of backscattered photon

Know energy where photoelectric and Compton interactions are ~ equally likely

Properties of Co-60 decay

EQUIPMENT

If knew volume of chamber, which parameters from TG-21 are not needed

If have 2 chambers of same model & manufacturer, which TG-21 parameters are likely to be different (list included: α , N_x , A_{wall} , N_{gas})

Put the parts in tx head in order (list included: monitor chamber, target, collimators...)

Matching: match linac parts with appropriate functions (list included: magnetron, circulator, waveguide...)

Given MHz, calculate the size of each microwave cavity

kV issues (heat vs. Brem efficiency, heel effect, output proportional to...)

MV transmission target properties

Methods to measure dynamic wedge

Methods of instant verification for in vivo dosimetry

Properties of LiF TLD

Properties of diodes

Problems with using film for measuring PDD

EXTERNAL RADIATION BEAMS

Matching: match electron energy with "rule of thumb" values (know R_p , %Brem, R_{50} ...)

Factors that affect virtual/effective SSD

Ideal properties of a phantom for an electron beam

If chamber in water phantom goes 5mm deeper on one side of CAX change in msmts =?

Properties of photon isodose lines

Most sensitive energy test

When electron beam is collimated to small field, what happens to output

Dose distribution for abutting electron and photon fields

What factors inc geometric penumbra

Issues when increase cone to skin distance for electrons

BRACHYTHERAPY

Calc air kerma strength from mgRaEq for Ir-192

Know typical DR for Fletcher at: point A, point B, bladder, surface

Matching: match isotopes with appropriate factors (know HVLs, half-lives, average/max energies...)

Given DR at 1 cm perpendicular to Cs-137, what is the DR at 0.5 cm

Calculate DR at 1.5 m given mg of implant, Γ , 25% atten by pt, and a TVL shield

Know what point A represents

Factors affecting Sievert integral

Prostate implant issues (TRUS, typical doses, urethral complications wrt EBRT...)

Given total dose from permanent implant, calc dose delivered at point in time

Matching: match the essential info (ISL, exposure rate constant, 8.25 Rcm²/mgh...) with the source strength specification (mgRaEq, Air Kerma strength, apparent activity...)

RADIATION TREATMENT DESIGN

Esophageal tx planning (typical beam arrangement, does it depend on which 1/3, ...)

Lung tx planning - issues related to 6MV vs 18MV for small midlung lesion (e.g. build-up and build-down effects)

Calc dose from PAB given information for SCLAV

Calculate dose at cord given dose at prescription depth
 Calculate total dose given several beams which traverse several cm of lung
 % change in PDD for 5 cm error in setup
 SAD to SSD setup, changes
 Dose calc for 4-field pelvis given TMR and depths
 Calc MU/deg factor for arc of certain angle
 Calc dose to point under block given diagram, TMRs for open & blocked fields, block transmission, dose to point in unblocked portion of field
 Gap calc (matching two hemi-body set-ups)
 Craniospinal junction – methods for matching fields
 For mantle field without compensation, which point receives most dose (axilla, cervical nodes...)
 Combined photon/electron for parotid (why combine, typical ratio, ...)
 Wedge transmission factor (Δ with depth, Δ with field size, dynamic wedge issues...)
 Compensators (list included: independent of depth, independent of field size, use less than equivalent thickness of tissue, brass comparable to cerrobond)
 Matching: match the best diagnostic study (CT, MRI, ...) with each anatomic site (prostate, glioblastoma multiforme ...)
 Disadvantages of using MRI for RTP
 Factors needed to determine size of tumor (TSD, TFD, etc)
 What can be determined from DVH
 General pros and cons of MLC
 3D BEV planning issues
 Critical structures relevant to backscatter from lead shields in electron beams (e.g. buccal mucosa)

SPECIAL TREATMENT PROCEDURES

Matching: match the special (IMRT, SRS, HDR, TSET, TBI) with the disease (myc fungoides, leukemia, glioblastoma multiforme, bile duct carcinoma)
 Given TMRs for neck and abdomen, calc lead to give equal midplane doses for TBI
 TBI calc – dose to ankle given info at midline and ankle with OAF
 Table requirements for stereotactic radiosurgery
 Purpose of dual fields for TSET
 Methods of IMRT (list included: wedge, dMLC, partial transmission blocks...)
 How much is the energy of an electron beam for TSET degraded by 3 m of air

RADIATION SAFETY

Fetal irradiation (know what happens when irradiate during preimplantation vs. organogenesis, whether neurological damage results if rads during weeks 8-15...)
 Primary barrier calc
 Neutron detectors
 Matching: use & occupancy factors
 HDR emergency procedures
 Package labeling/transportation (know definition of TI, what needs to be on label, ...)
 Source leakage limit
 When can pt who received pharmaceutical leave hospital
 Door shielding – what is needed from inside of door to outside
 Know average energy of neutron distribution
 Misadministrations – know %
 Dose to fetus from mantle field of pregnant patient comes from...

QUALITY ASSURANCE

TG-40: includes QA for which (list included brachy sources, chart review, CT sim...)
 TG-40: Co-60 monthly QA tasks
 TG-40: tasks to perform each time an electrometer/ion chamber system is used
 TG-25: know specs for flatness, symmetry, uniformity index

BIOLOGICAL AND CLINICAL CONCEPTS

TD_{5/5} (TD stands for..., first 5 stands for..., second 5 stands for...)

Common late effects for thoracic irradiation

Matching: Critical structures (...) associated with treatment sites (larynx, ...)

Be able to put in order of escalating dose for cure (list included: breast, Hodgkins, seminoma, prostate)

Matching: match TD_{5/5} values with correct organ (list included: fetus, lung, optic chiasm...)

Know what PTV includes/represents

Meaning of $\alpha:\beta$ ratio

D₀ on survival curve represents...

Matching: match parts (alveoli, choroid,...) with anatomy (lung, eye,...)

ABR 2001 Exams

As a general strategy I would recommend looking into old RAPHEX exams. Do as many as possible. I also found that there were several questions posted on the ABR web site that looked very similar to those listed in the exam.

General Exam

For this section, the key is to study Hendie's book: Medical Imaging Physics

- If the efficiency of a 10 atm GM counter is 90% and drops to 1 atm, what is the new efficiency
- Detector has count rate of X
- Neutron activation, what is the activity of a ^{59}Co source irradiated in a neutron flux with an activity of X
- Radiation protection question
- Statistics question
- Voltage question similar to demo question on web site. What is the electric field at 0.5 cm from electrode.
- Survival fraction given D_0 , n , what is D_q
- Calculate speed of film given HD curve

Radiation Oncology

Kahn's book: The physics of radiation therapy is the key reference for this exam.

- What is the dose at point X m from source
- Match the energy with isotope
- Numerous questions regarding shielding for brachytherapy
- Given the basic calibration data such as charge, N_x , Pion, Prepl, etc what is the dose / MU value for the ion chamber. This equation required you to basically plug in the TG-21 values and compare your answer to the five choices.
- MU calculation involving isocentric treatment plan with SAD = 100 cm. Required to look up data from several tables and determine what the correct MU is.
- MU calculation involving extended SSD calculation. This required knowledge of Kahn's method for extended SSD treatments. The SSD was 110 cm.
- Shielding calculation
- Tangential breast treatment question where you were required to determine the angle between the CAX of the two tangential fields.
- Single TG – 40 question
- Several questions regarding Federal regulations etc.

ABR Written Exam 2002

General Physics:

A ball is thrown into the air with a given velocity. When will it reach its peak.

A question about the angular momentum.

A weight is sitting on a beam that is supported by two columns. Given the location of the weight on the beam, calculate the force on each beam.

An electron travels from the cathode to anode (Voltage and distance was given). How long it takes for the electron to travel this distance.

Given the initial activity and the activity at a time t in a biological system (e.g. the effective half-life) and the physics half-life, calculate the biological half-life.

Part (40%) of the activity is lost with a half-life of x , the other part (60%) is cleared with a different half-life, calculate the activity at a time t .

Two isotopes have a given count rate in window A and B respectively. For a mixture calculate the activity of isotope B.

An ultrasound beam impinges at an angle X onto an interface. What is the angle of the reflected beam (densities were given)

A question about the pulse repetition frequency of an ultrasound transducer. The focal depth was given

At a given frequency an ultrasound beam is attenuated by 20 dB. If the frequency changes from 2 to 4 MHz, what is the new attenuation.

RC circuits.

Compton scattering. Angle and initial energy are given. Calculate energy of scattered photon.

Beta plus decay, amu 's are given. Calculate the max energy of the positron.

The hex equivalent to a binomial number.

Calculation of accumulated dose

What is the accumulated dose of an I-125 implant after 60 days.

Image of 512x512, gray scale of 64, info transmitted at X baud rate, how long does it take

Two batteries are connected in series through a resistor. One of them is flipped, what is the new current.

A 2 tesla MRI scan. The sample has a contamination of 10 ppm. What is the noise that is introduced.

Clinical:

Where is the foramen Magnum.

What is Meiosis

Where are the adrenal glands.

What makes the gall bladder contract.

Flow of blood through heart.

How many cranial nerves are there

If a patient is dehydrated, the patient lacks ???

What do you use a thallium scan for

What scan do for a Hiatal hernia

Function of cerebellum

Function of spleen

What connect the two cerebral hemispheres

Male chromosome are XY or XX

Graph of two survival curves, What is identical (D_0 , D_q , n , OER)

Order of the small intestine

What causes portal hypertension

Which artery is the main blood supply for the liver

Part II, Therapy:

Lots of shielding questions

How often do you calibrate the barometer

A concrete wall (66 inches) is to be replaced with a thinner wall (36 inches) consisting of concrete and steel. TVL of steel and concrete were given. Calculate the steel thickness.

Lots of MU calcs, SSD to SAD, Entrance-Exit dose, extended SSD.

TG-51: for photon calibration, above how many MV do you have to use how thick a layer of lead at how many cm from the source?

How much difference will the calibration be by using TG 21 and TG51 for photons? 1% higher, 3% higher, same, 1% lower, 3% lower.

A brachytherapy line source, with three separate sources. What is the difference in the dose rate for a point perpendicular to the center source relative to a point perpendicular to the end source.

What is the difference in a barometer reading if the readings are taken at a height of X and X+50 m.

What does the term sliding window mean in IMRT

Couch kick on a cranial spinal treatment.

A sim-film is taken for a 100 SSD setup. Patient is treated at 80 SSD. What is the assumed Source-to-Film distance to correctly cut the blocks for the new 80 SSD.

For a x ray tube with 100 mA and 100 kVp, the HU has a sigma of 1.5, if the current is raised to 400 mA, what is the new sigma of HU?

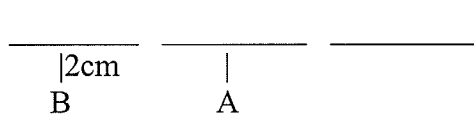
1. There are three hours to do the test. Questions #1-50 make up 40% of the grade. Questions #51-75 make up 60% of the test. You will have enough time to finish the test if your work fast.
2. How often do you have to re-measure the room shielding for HDR.
3. What happen in after the thyrotron fired?
4. Given the attenuation coefficient of $0.018 \text{ cm}^2/\text{gm}$, depth of 5.5cm with d_{max} of 2.0cm, What is the percent depth dose at depth? TSD=100
5. Three 10 mg Ra-Eq each Cs sources in a straight line. The active and non-active lengths are given. Point A is 2cm from center source. Point b is 2 cm from the first source. What is the exposure ratio of at B to A? See picture below
6. 

$\overline{\quad\quad\quad}$ $\overline{\quad\quad\quad}$ $\overline{\quad\quad\quad}$
 $\quad |$ $\quad |$ $\quad |$
 $\quad \text{2cm}$ \quad \quad
 $\quad \text{B}$ $\quad \text{A}$
7. What is the best device for IVBT source calibration?
8. According to the task group, where is the reference point for IVBT? (2 mm from source center)
9. Given Field AP-PA 10.4cm and Sup-Inf 16.8 cm with SAD setup, find the table kick angle to remove the beam divergent.
10. Given source size 3cm, SSD of 100cm, depth of 10cm and SDD of 30cm, Calculate the physical penumbra.
11. A point is 2 cm outside of a 10x10 treatment field at 10cm depth, what % of dose does it get?
12. Patient simulation was done with 17.5 x 22, 100 SAD setup, thickness of 22 cm, film at 130cm. It was decided that the patient will be treated with 100 cm SSD setup instead. What magnification factor do you use for the Sim film to cut the blocks?
13. Patient was treated with 100 cm SAD setup with thickness separation of 22 cm. Patient is moved to cobalt with 80 cm SSD setup. What is the new field side?
14. Determine the virtual source distance given the measure reading at 100cm, 120 cm, and 140 cm and the readings are 100, 44, and 25 respectively.
15. A given dose rate in air at 40" from the superficial x-ray source 125KvP, 10R/mA-s. What is the dose rate at 2cm depth ($P_{\text{dd}}= 0.6$, $\text{BSF}=1.15$, $f_{\text{med}}=0.9$)

16. Given the TVL of steel and concrete. The calculated shielding wall thickness needed was 66 inches of concrete. You have only 36 in for wall space, how much concrete should be replaced by the steel?

Lot of Shielding problems

17. Basically, just calculate the transmitting factor and determine how many TVL needed. You have to watch out the mix units i.e. time in min, week etc...Also, some linac head leakage and scatter problems.
18. Patient is being treated with SAD setup with iso at 9 cm depth, calculate the exit dose giving the PDD or TMR at 9 and 18 cm depth.
19. How much charge would you get for a given exposure rate and chamber size, info given: $1R=2.58e-4$ C/Kg, air density = $1.293e-3$ Kg/cm², chamber size = 0.19 cm³.
20. There is a 1 mm crack on the linac vault and you a large ion chamber to measure the exposure rate of 1 mR/hr. You move the chamber away from the crack behind the "good" wall and the exposure rate is 0.5 mR/hr. Is your exposure rate at the crack smaller or larger than 1 mR/hr?
21. Patient treated with 3 fields, equally weighted, 180cGy. Two posterior fields go through 9 cm of lung and SSD is 82 cm. If you don't correct for lung inhomogeneity, what is the percent error at isocenter?
22. You have a universal 60 degree wedge with the wedge factor of 0.5. You want to use a 30 degree wedge. What is the ratio of MU for the open to wedge field ?

A few beam spoiler questions

23. For treating breast tangents- sometime 10MV is used with beam spoiler- Why?
24. A few electron obliquity question- ie. How does it affect surface dose, depth dose etc...
25. Given aluminum and water mass and electron density, determine how thick the aluminum compensator should be to compensate 5 cm of tissue. Info given: Water: $3.2e23$ e/g, 1g/cc, Al: $2.9e23$ e/g, 2.7 g/cc.
26. 18 MV photon linac, what is the largest contribution to exposure behind the gantry stand. Is it patient scatter, wall scatter, col scatter, head leakage etc...
27. TG 40, how often do you check electron output?
28. TG 21 and TG 51, what is the % different in measurement and which is higher, lower, or the same?

29. You have a 6x6 electron cone with a 4x4 insert, what doesn't change? (R practical)
30. Given an isotope with a know half-life, how long does it take to give 95% of total dose.
31. You want to limit a total dose at 1 meter from a patient that has brachytherapy implants to 500 mRem, what is the maximum initial dose rate? I think the isotope was Iodine 125.
32. How often do you have to calibrate the barometer according to TG 40?
33. TG 40, what % is the flatness of the beam should be?
34. You are 50 meter above the airport, what % change do you expect to see in pressure?
35. Given an AP and a Lat film with two points identified, find the distance between them.

Part 1 of the ABR exam 2003

Physics Section:

The CD is great and I thought it was helpful and relevant to what was on the test. Here are some specific questions I remember.

1. There was a question on the STD of a binomial distribution
2. A question on a proton traveling at a certain velocity and colliding with an unknown particle. The velocity of both the proton and particle were given and the question was to figure out the mass of the unknown particle.
3. Converting the energy in joules to mass in a metric ton
4. A couple of questions on magnification given SID, SOD, OID.
5. A question that gave the rms voltage and a transformer and asked the peak voltage.
6. Given a sound with a certain frequency if you are traveling so fast towards it what frequency do you hear
7. The sensitivity given TP, FP, TN, FN.
8. How long will it take to transfer a set of images if the transfer rate is X bits/s and the images are a 1024 matrix with 8 bits/pixel with a transmission overhead of 25%.
9. For a conventional CT, images are 512x512 with 256 shades of grey. How many can be stored on a 5.0 GB storage device without compression?
10. Given you have a solution which is 60% NaCl and contains 45 grams of NaCl. How many grams of NaCl do you have to add to make a 75% NaCl solution?
11. Given a ball shot at a velocity of 2000 km/hr at a 45 degree angle. At what distance will the ball land? Ignore drag forces.
12. Which laser would not be used for fiber optic communication? HeNe, YAG, CO₂?
13. Given Isotope A and B. Isotope B has two times the activity of A and emits a particle with twice the energy. The dose from B will be X times that from A over the same time
14. The entrance dose is 4 Gy and the exit dose is 25mGy on a patient that is 22 cm thick. What is the dose at the middle of the patient?
15. Neutron activation.
16. Neutron loses 0.5 of energy per collision. How many collisions to lose x energy?

17. Stats questions. Poisson.
18. Calc. Kerma. They give both energy transfer coeff and attenuation coeff.
19. Calc effective atten Coeff for a given compound
20. Calc the effective Z for a compound
21. Calc the dose to the gas in a dosimeter knowing the energy absorbed in the gas, the volume of the gas and the density of the gas
22. Given a graph of velocity of an object vs. time, calculate the distance that the object traveled over the time period shown in the graph.
23. Given an equation for the potential in x, y, and z, calculate the components of the electric field.
24. Calculate a temperature and pressure correction for an ion chamber given the temperature and pressure at the time of measurement.
25. What is the angle between two vectors u and v if the resultant of the two vectors is perpendicular to u and has a magnitude that is half of v?

Clinical Section:

I thought this was really easy especially after going over the CD. I'll try to remember the only question that I don't remember from the CD.

1. Which type of cancer is most easily seen on a CT?
2. Where is the hilum located?
3. A question about dysplasia
4. Where are the islets of Langerhans
5. How many main lobes of the liver
6. Given a CT slice and a list of organs, find which organ is not included in the slice shown.
7. T1 vs T2 MR image. Given an image, choose what the true statement.
8. Extrapolation number. Given the survival curves for two different cell lines, name what is the same for the two. Given a graph showing D_0 , D_1 , D_t , extrapolation number.
9. Given a list of bones, name which one is in the lower leg.

10. Given list, which is not a bone of the upper extremities?
11. Where is CSF made?
12. Where do you find the glomerulus?
13. what is the function of the alveoli?
14. What is the most radiosensitive part of the eye?
15. What fluid lubricates the joints
16. What is the dose needed to cause skin erythema?
17. Dose limits. Dose to double cancer rate.
18. Dose vs. effect in embryo
19. Average effective background at sea level including Ra
20. Which organ absorbs the most water?
21. Which is the most sensitive organ given a list.

2004 ABR Written timing considerations. I put a lot of effort not just into learning the material but into learning fast ways to solve problems. It's not good enough if you know how to solve a problem but it takes twice the allocated time per question. Here is how I went with regard to time. I simply divided up the allocated time evenly on a per point basis:

Part 1 (General) I was 15-20 minutes ahead at the end of the first 50 one point questions, then picked up at least this amount again during the 25 three pointers. This meant I had something like 45 minutes for review of my flagged questions after completing a first pass – this was much faster than I expected.

Part 1 (Clinical) Similar to candidates from previous years, I finished with plenty of time to spare and actually reviewed every single question.

Part 2 (Therapy) Again I was 15-20 minutes ahead at the end of the first 50 one pointers, but then lost all of this during the 25 three pointers. Some three pointers were quite fast, but quite a number of them were very time consuming eg the TG51 question (number 2 below) has many small calculations within it. I used all but a few minutes to get the exam done, with only a few flagged questions reviewed at the end.

Part 1 (Clinical) Similar to candidates from previous years, I finished with plenty of time to spare and actually reviewed every single question.

This recollection of questions should provide a tremendous help – just like previous candidates recollections did for me. Good Luck!

2004 ABR General Part 1, Written.

1. Two counts of same source, what counts to give 95% chance that the two counts will measure within 4%. (I did $0.04 = 2\sigma/\mu$)
2. Classic Ctrue, Cobs, dead time question.
3. 1600 counts over 4 mins (meas), background 900 counts over 3 mins (measured). What is the standard deviation in net count rate (cpm)?
4. XXXX n/cm²/sec activates YYYY atoms of ⁵⁹Co per unit time. What is the max activity of ⁶⁰Co (Ci) that can be achieved. (I didn't use the n/cm²/sec)
5. Chromium neutron activation. Half life given. When is 80% of max activity established.
6. Effective weight if half body (ie below diaphragm) irradiated. Weights for various organs of the body given. Had to know things like lung, breast, thyroid and esophagus are above diaphragm so could remove them from the total.
7. Had an A to B to C decay. (like ⁹⁹Mo – ^{99m}Tc – ⁹⁹Tc but not told this). A has 10hr half life, B has 1 hour, C stable. If only A to start, what is ratio B/A at 5 hours. Answers 1.0, 0.6, 0.3...
8. In an isotope where gamma emission is forbidden, what else is an alternative – internal conversion.
9. Decay emits only neutrinos and characteristic x-rays. This is? Electron Capture.
10. P31 1.71MeV gamma ray (given). Best shielding material is
A. 1mm Acrylic, B. 1cm Acrylic, C, D, E.... Pb of various thicknesses
11. Max dose patient in hospital near “radioactive” patient can receive is A. 1mSv, B. 5mSv C....higher doses.
12. Physicist does 50 brachy patients per year. Max dose allowed (per NCRP 116) to ring badge per patient is?
13. KM Auger electron energy given KLM energies (need to know Aug. e emitted from shell where transitioning electron originates)
14. Electron Anode to cathode time? Given voltage and distance. No mass of electron given. A fast solution involves calculating the final $\gamma (=1/(1-v^2/c^2)^{1/2})$. Solve for V_{final} , assume $V_{average} = V_f/2$ (OK if only few 100 keV), then get time from distance.
15. Electron 0.9c, what is the total mass / energy in MeV. Given $m_0 = 0.51$ MeV.

16. Electron accelerated through 4MV, what velocity? Fast solution again uses γ
17. Voltage as a function of radius $V=130\log_e(r)$. Electric Field strength V/cm at $r=0.5\text{cm}$?
18. Unit vectors $\mathbf{j} \times \mathbf{i}$ (ie \mathbf{j} cross \mathbf{i}) = - \mathbf{k} .
19. Length of $\mathbf{i} + \mathbf{j} + \mathbf{k}$
20. Neutron of velocity XXXX hits and is captured by ^{59}Co nucleus. Before ^{60}Co decays, what is the velocity of the ^{60}Co nucleus (I applied simple cons of momentum)
21. Photons of two different energies of initial number ratio 4 to 1 pass through 20cm of water. μ given for both energies. What is the number ratio of photons after passing through the 20cm of water.
22. Find the μ of a mixture of materials. weight fractions given. μ/ρ of components given, ρ of mixture given. Solution: add μ/ρ by weight fraction then multiply by ρ of mixture.
23. $\Gamma = 1.5$ (units) for an isotope with 100% efficiency, 1 MeV per decay. What is Γ (same units) for an isotope with 80% efficiency, 2 photons per decay, each 0.75 MeV.
24. Ultrasound assumes 1540 m/s (given). A layer of fat 2cm thick has actual velocity 1460m/s (given). The ultrasound will measure the fat layer as ??? cm thick?
A. 1.8 B. 1.9 C 2.0 D 2.1 E 2.2
25. An ODI light takes a path at 35 degrees to a linac beam axis. A 10mm thick block tray is inserted into the path of the ODI perpendicular to the linac beam axis. (no diagram given). What is the lateral shift in the ODI light. The refractive index of the block tray is 1.5.
26. An ion chamber survey meter has 90% efficiency at 10 atmospheres. The pressure in the chamber drops to 1 atmosphere. What is the new efficiency? Answers started at 21% and went up (ie 9% was not there). If you consider a new linear attenuation coefficient of $1/9^{\text{th}}$ the original I ended with 21%.
27. No CT in parts 1 or 2 (other than anatomy in clinical section)
28. Radiofrequency used in 1 Tesla MRI is... (not given 42.6 Mhz/Tesla gyromagnetic ratio) 42.6 Mhz was a possible answer.
29. No α/β radiobiology questions (in 1 General or clinical)
30. Do is the ??? on a cell survival curve (question was worded so that the shoulder was not to be considered) A. 37% cell survival, B... other options that didn't look right. This question may have been in the clinical section.

31. Function $y=2x-e^x$. Find the position of the maximum.
32. $\int_{0.1E_m}^{E_m} (E_m-E)dE$. Evaluate the definite integral in terms of E_m .
33. Calculate the Kinetic energy in a rotating disk given the moment of inertia and the angular velocity in both revolutions/sec and radians/sec.
34. A Petabyte is $???? \times 10^{12}$ bytes
A. 0.98 B 1.02 C 1.05 D 1.07 E 1.10
35. A number (given) of CT images of size 512×512 are compressed with 2.5:1 compression. How long to transfer these images over a T1 line (T1 line bandwidth of XXX Mbits/sec was given). No information was given about how many grey levels or bits or bytes per pixel. I assumed 8 bits (1 byte) per pixel and got an answer that was available.
36. A number of detector area / distance from source / geometric efficiency problems like others in previous years. Some requiring steradian calculation.
37. Something about specificity is associated with One of the answers was “ROC”. Various other statistical terms were provided but didn’t appear to have anything to do with sensitivity / specificity. I don’t recall anymore, but gave this anyway.
38. A ball is thrown vertically. Question asked for time or height to top – I don’t recall. Initial velocity given, but not gravitational acceleration. Velocity given in km/hour.
39. A circuit diagram (diagram given) with a battery in series with a switch, then resistor A then resistor B, then back to battery. Inductor L is in parallel with resistor B only. A long time after the switch is thrown, how much current goes through resistor B? I think the answer is zero as it all goes through the inductor – this was an option.
40. An electrical meter has an internal 5k ohm resistor and registers full scale at 50 micro A. How many meg ohm to insert in series to turn meter into a XXXX range voltmeter? The answers were all tenths of a meg ohm apart so you could ignore the effect of the 5k ohm internal resistor and just apply $V=IR$.
41. An electrical supply line loading question. Some large piece of electrical equipment has a peak power output of XXXX kW. If this is maintained, but voltage changed from 480V to 240V, by what ratio will supply line losses change. I think the answer is an increase in losses by a factor of 4.
42. What is unerasable data storage called – A. RAM, B. WORM.
43. Typical shielding in a diagnostic x-ray facility is Xmm of lead...A. 1mm B 5mm

44. Scatter dose at 90 degrees at 1 meter (asked to assume field size = 400cm²). I answered 0.1%

2004 ABR Clinical Part 1, Written.

1. Largest bone in lower leg – tibia, fibula.
2. Sagittal MRI labeled with cord, disk, spinous process, ilium. What orientation is this (answer sagittal). Which is incorrectly labeled? The “ilium” label appeared to be pointing to a very bright (ie not bone) lower pelvic structure that I think was the posterior most fluid filled pouch in the floor of the pelvis.
3. CT through liver / spleen. Which is false – labels were at liver , spleen, this section is at L4-5 (I chose this).
4. Location of pancreas – anterior to stomach, between duodenum and spleen (I chose this).
5. Lots of questions on the order of blood circulation through the heart and associated vessels.
6. What structures pass through a hole (worded differently) in the diaphragm. I chose an answer that had esophagus, aorta and vena cava. Other options contained the spine – that’s all I recall.
7. Numerous questions on the effects of radiation at various stages of fetal development.
8. When does organogenesis begin.
9. Corpus Callosum is in thebrain, thorax, abdomen, pelvis. Leg.
10. Irradiation in the first week following conception results in Intrauterine death, leukemia in the child, mental retardation, congenital abnormalities
11. Irradiation in late stages of pregnancy results in Intrauterine death, leukemia in the child, mental retardation, congenital abnormalities
12. A patient has reacted to contrast. This would most likely be from barium, iodine, gadolinium, gas bubbles, saline.
13. Maximum dose to fetus from which exam
A. KUP AP B. Lateral Lumbar X-ray, C Cholangiogram.D Barium Enema
14. The peritoneum is in the A. Abdomen, B. Brain, C. Thorax.
15. Blood drains from the vena cava into ? Right Atrium

16. Blood leaves left ventricle into what? Aorta
17. Systole Volume = 36cc, Diastole volume = 91cc. What is the ejection fraction of the heart.
18. What is opposite to LPO. (RAO)
19. This may have been in part 1 General. 1 Gy to testes of 20 year old man, result is...
A. increased libido, B. decreased libido, C. permanent sterility, D. temporary sterility.
20. This question may have been in the part 1 general section. Fractionation is used in radiation therapy because of "large shoulder in survival curve" appeared to me to be the only reasonable answer. I don't recall other options.
21. This question may have been in the part 1 general section. The biological response model extrapolated to low dose is assumed to be "linear non-threshold". I don't think I got the wording of this question right, but the intention is there.
22. This question may have been in the part 1 general section. Regarding the Oxygen Enhancement Ratio (OER) "Oxygen promotes free radical formation" appeared to be the only reasonable answer.
23. Regarding fibromyalgia: A. Treated with radiotherapy B. Causes aches pains stiffness and lethargy C causes swelling
24. Virtual Colonoscopy uses: A. PET B. MRI C. CT D. SPECT E. US
25. Autonomic Function is controlled by: I don't remember all the options but the brainstem or something similar was there with all other options in the forebrain.
26. The master hormone gland is the: Pituitary
27. Most stable product of hydrolysis(?) radiolysis (?) of water is:
A. OHdot B. Hdot C. H₂O D. H₂O₂ E. Free Electrons
Dot indicates free radical.
I must admit I still don't know the answer to this. I would have thought a question asking about the most unstable product would be more clinically relevant.
28. Sensory cells are in what layer of the eye? A. Sclera B. Choroid C. Retina ...
29. Hypoglycemia can be caused by: A. glucogen B. Insulin C... other answers that didn't appear relevant.
30. Calcium levels in the body are controlled by the: A. Parathyroids

31. Functions of the spleen.
32. The lymphatic system drains into the: A. Subclavian Veins B. Vena Cava C. Aorta.
33. Male Chromosome – XY
34. Cell Target – DNA
35. Platelets are used for – clotting of blood.
36. Where is the calcaneus found A: foot, BCDE other options far removed from the foot.
37. Brain irradiation to 60Gy (didn't say single or fractionated). What are the late effects?
I said necrosis.
38. Number of cervical vertebrae.
39. Function of the liver – produce bile was the only correct answer.
40. Gas exchange in the lungs is by – A. diffusion, B. osmosis
41. A bundle of nerve fibers is called a – plexus.
42. Ovaries produce which hormone Estrogen appeared to be the only reasonable answer.
43. Radiation is a teratogen because: A.It causes birth defects, B. it causes cancer C. It induces mutations
44. The most oxygenated blood can be found in the A. Aorta B. Pulmonary Artery C. Pulmonary Vein, D. Iliac Artery.
45. Blood leaves the left ventricle into the: A. Aorta B. Pulmonary Artery C. Right Atrium D Left Atrium.
46. Most food is absorbed in the: A. Stomach B. Duodenum C. Small Intestine D. Colon E. Rectum
47. Blood leaves the Vena Cava to enter the right atrium.
48. Number of lobes of the liver
49. Number of lobes in the lungs
50. Artery to the liver
51. Number of temporal lobes in the brain

52. OER with dose rate or LET (I can't recall which) increases / decreases.

53. Radiation therapy works because of Various statements about the shape of the dose response curve. A statement about a "wide shoulder" looked best to me. Other statements concerned things such as synchronization / rephasing of the cell cycle.

2004 ABR Therapy Part 2, Written.

1. HDR, three dwell positions (1, 2 and 3 – 2 in middle) 1cm apart in single channel. Dose points A,B and C 1cm perpendicular to dwell positions 1,2 and 3 respectively. Dwell times in 1 and 3 are the same. What is the ratio of dwell times 1 to 2 to make dose A equal dose B.
2. TG51 question (no TG21 in whole exam). Given P_{pol} , P_{elec} , T (deg C), P (mmHg), $V_{high} = +300V$, $V_{low} = +150V$, 100mu Reading for $V_h = 1.71$, 100mu reading for $V_l = 1.70$, given ^{60}Co N_{dw} Gy/C for chamber, given pdd photon, given kQ (not asked to do energy determination to find kQ) calc cGy/mu at d_{max} for photon beam. Answers approx 0.6% apart. (Also given plenty of irrelevant information such as TG51 electron beam parameters)
3. Simulator shielding question, NCRP 116 level to worker with office above simulator room. Occupation mentioned – I don't recall but was an allied health profession not related to radiation oncology/ radiology. Floor to floor = 12 ft, iso = 48" above floor, SAD = 100cm, given $U=1/4$. $W=800mA.min/wk$. Asked to work out the thickness of concrete shielding required. Answers about 4mm apart. Provided with a graph of $R/(mA.min)$ at iso on vertical axis (log scale) vs concrete shielding thickness (cm) on horizontal scale – with the log scale, the plot was reasonably linear. Basically I think what you had to do was find allowed $R/mA.min$ at point where person is sitting, then project back to iso to give your number for the Y axis then read across to get concrete thickness.
4. AP/PA doses given from each field to cord for 200 cGy to tumor. (62cGy, 150cGy respectively). Cord block put in PA, new cord dose is 18% of original. How many fractions need cord block to limit cord dose to 40Gy?
5. Counts given (cpm) for reference source with known activity (mCi). How many counts allowed to stay below wipe test leakage limit – limit not given ($5nCi?$).
6. 2cm diameter lead pig inside polyurethane foam inside 30cm diameter shipping drum. HVL Pb given. Exposure rate constant of ^{192}Ir given (but not the one I know!). Calc max activity to keep below 50mR/hr on surface. Another variant of this question used ^{137}Cs (again I didn't recognize the exposure rate constant provided), activity provided and asked to calc thickness of lead to reduce exposure rate to certain level (TVL given).
7. Parts definitely not included in EPID – options were ion chamber, CCD camera, mirror, silicon screen, some other dose detection device.
8. TBI, diode reading 450cGy on surface, presc midline 600cGy POP laterals, 30cm separation. TMR's given, 350cmSSD. What is error in midline dose? Answers approx 5% apart, both + and -. I had to assume entry beam only, and diode reading relevant to d_{max} (not surface – no TMR at surface given) to get anything reasonable.

9. Three beams 120 deg apart, AP and post obliques. Each 15 cm depth to calc point. 60cGy from each beam to be delivered to calc point. Post beams have 9cm lung, $\rho = 0.33$, TMR's given at 3,6,9,12,15 cm. Ratio of μ 's post to ant.
10. Several TMR and PDD questions that needed the 4A/P rule.
11. Extended SSD calc that needed the Mayneord F Factor. Was only given a graph of output vs field size ie could not separate S_c and S_p .
12. Ratio of d_{max} (25 MV)/ d_{max} (4mv) for same dose to midline using POP setup with SSD =100cm. PDD's given.
13. Neutron dose equivalent (mSv) outside field per photon Gy at isocenter.
14. Neutron dose equivalent ratio 18MV vs 15 MV. Answers were fairly widely separated ie 1, 2, 5, 10, 100.
15. Given distance iso to maze and maze length, neutron dose at iso (mSv) per photon cGy at iso, what is neutron dose (mSv) at door per photon cGy at iso. Told TVL of neutrons is 5m, but not where it applies. I applied kersey formula ie ISL iso to maze, then 5m TVL down maze to door.
16. Numerous questions of dose ratio where had to use TMR ratio and change of ISL.
17. Dual scattering foil in linac, when change to electron mode (from photon) what happens. A. gun current reduces substantially, B. Both scattering foils are in place C. other options that were way off.
18. $g(r)$ for ^{125}I vs ^{103}Pd . A. same at all depths, B. Pd exceeds I beyond 1cm, C Pd exceeds I beyond 4cm, D. I exceeds Pd beyond 1cm, E. Same at all depths.
19. No TG21 questions
20. No gamma knife questions
21. No ion chamber current from exposure rate or dose rate or in part 1 either.
22. TG 40 photon flatness spec.
23. TG40 field size spec A. 2mm/1%, B. 2mm/ 2% C others not 2mm
24. TG40 how often do you check well chamber leakage.A. 2 years, B. Every use, C....
25. TBI – what is not true – A. Dose Uniformity < 15% B. Tissue Equivalent compensators are used C. High SSD D. AP preferred over lateral.

26. Biggest impact on fetal dose according to TG36. A. Distance to fetus, B. energy C. Blocking, D. Depth below abdomen surface.
27. S/rho and rho given for lead. Calc MeV/cm then use to calc lead thickness needed to shield 18MeV beam.
28. HDR 192Ir. Patient treated with time XXX with Activity YYY on Aug 15th. Source replaced with activity ZZZ on Aug 17th. Treatment time on Aug 22nd is ? No 192Ir half life given.
29. Nothing on TBElectron
30. 10MV through 6cm lung, dose actual vs dose without inhomogeneity. No other data given.
31. A question involving 10mg Ra – simple application of $\Gamma x A/d^2$ – but needed to know (ie not given) exposure rate const. = 8.25 Rcm²/mg.hr
32. Shielding question. 36 in space available for needed 6 TVL (this information was given). Pb TVL given. Concrete TVL given. What is the minimum thickness of Pb needed.
33. How many TVL's in a linac head.
34. No MLC questions
35. **The only IMRT question:**
In IMRT the physicist does not define: A. Beam Weights B. Field Sizes C. Gantry Angles
36. Field size required at midplane is 25cm, maximum can open is 20cm. What is SSD? (separation = 22cm)
37. Sim film taken at 102cm SSD, SFD 140cm. Want to treat at 120cm SSD. What distance to film should be used when cutting blocks.
38. Standard question about the couch kick angle required to make inferior borders parallel on lateral brain fields.
39. Breast Tangent pair. Field widths at 100 SAD = 10.5 cm. LAO has gantry angle 45 degrees. What gantry angle does RPO have such that posterior borders will be parallel.
40. I'm vague on this one but I'll give it to you anyway. The question went like The simulator couch wouldn't go low enough, so the film was taken at X SSD, separation 25 cm, distance to film = 140 cm. Physician wants to treat at 132 SSD, simulator film needs to be placed at what distance to cut blocks.

41. No diagram with this one making it tough. Patient on simulator couch with isocenter 5cm right of midline. Wire placed on midline (didn't say A or P). R Lat film taken. Measured cord depth of 6.7cm, but therapist forgot to reset isocenter to midline. What is the true cord depth. If you think this is confusing, then I agree. Basically I think the depth was measured assuming isocenter at midline, then question was asking what is the true depth.

42. PDD for wedge increases over open field due to: A. Photon interactions in the wedge B,C,D,E..... other options that didn't look right.

43. Beam steering vs gantry angle in a linac. Signals to steer originate from ion chamber various other options.

44. Considering a dual ion chamber scanning water tank, an error in the PDD (a shift up or down – I don't recall which) is **not** due to A. incorrect zero – ie set above water level B. RF interference C. water / air temperature differential D. Stepper motors not calibrated correctly.

45. No electron Arc questions, no gamma knife questions, no SRS questions.

46. Electron cutout changed from 6x6 to 4x4. What doesn't change, A. Bremstrahlung B. Output Factor, C. Depth of 80%, D. Surface Dose.

47. I50 ionization depth of an electron beam is 5.1 cm. The energy of the beam is

48. Saturation in an ionization chamber refers toA. voltage high enough to prevent recombinationother options that were not correct.

49. A survey points a linac beam at a primary wall and measures 2mR/hr. Is this OK? There were various options in the answers, but this was the point of the question.

50. An ion chamber is used to perform a survey. You also need all of the following except: A. Dose rate of linac B. Sufficient buildup around the survey meter C... other options that looked to me like they were required.

51. SAR for this radial section: Diagram given, table of SARs given.

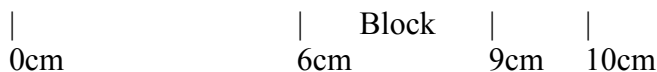

52. Classic electron ISL calculation straight from Kahn, ie calculate the effective SSD, given energy, field size, dmax (2cm), given slope of $(I_0/I_g)^{1/2} = 0.0111$.

53. Superficial question. Measurement at end of cone gives a reading of 150. Measurement at 10cm from the end of the cone gives a reading of 52.3. What is the effective SSD at the end of the cone.
54. No TG 61
55. Purpose of the guard ring in a plane parallel chamber is to? A. "Define the collection volume" appeared to me to be the only reasonable answer.
56. A question where you were given air kerma and had to calculate roentgens from this. I think you just divide by 0.876 rad/R – this gave one of the answers.
57. Dose to cord from AP/PA 100 SAD setup. 22cm separation, cord 4cm deep, 200cGy to isocenter. TMRs given.
58. Most radiation sensitive part of the eye is lens
59. TVL is related to HVL by A: $TVL = \ln 10 / \ln 2 \text{ HVL}$, B... other impressive but erroneous relationships.
This rule and it's generalization can be used to speed up all sorts of calcs, not just in shielding but with regard to time as well – use it!
60. Film exposed for dosimetry. Given transmitted light is 200 times smaller than original, what is the dose? OD vs dose table provided that required interpolation.
61. Electrons at extended SSD, which is true?
A. Width of the 90% extends proportionately B. Penumbra increases C. Output follows ISL with 100 to source ...
62. What happens when you change from 15cm field size to 20cm field size for electrons. No energy given. Various combinations of change in surface dose (increase / decrease) and change in d_{max} (increase/decrease). Only one option had no change in surface dose (which I chose)
63. Why does the equivalent square technique work? A. Because scatter doses are equal between square and rectangular fields, B.other options involved statement about collimators and scatter that sounded wrong
64. Scatter and leakage shielding thickness calculations are equal. The shielding that should then be used is: A $T_L + 1\text{HVL}$, B other options including $T_s + T_L$, $T_s + 1\text{TVL}$.
65. Order of materials in door for high energy linac – inside to outside.
66. Electron backscatter from internal shield versus Energy and Z – just had to know increase vs decrease.

67. Four field prostate treatment to 200cGy. What is the dose to anterior rectum. No other information was given, anterior was in bold. I answered 200cGy.

68. What should you check with each use of an ionization chamber / electrometer.

69. Classic isocentric POP where you had to calculate the maxdose / midplane dose ratio. Given TMR table, output factor as a function of field size graph (normalized to 1.000 for 10x10), cGy/mu at dmax for 100cm SSD and 10x10, no Sc or Sp given anywhere in the test.

70. A 60Co single field calc 100SSD, cGy/min at dmax given. PDD table given, BSF table given, TAR table given. Prescribed dose was 300cGy to 10cm deep. Had to use 4A/P to convert to square field (had to use 4A/P on numerous rectangular field questions).

71. Had to do single field 125 cm SSD calculation. 300cGy to 10cm deep. Given output factor as a function of field size graph (no Sc or Sp which in my opinion makes it impossible to do this question accurately), given PDD table, TMR table, given output at dmax for a 10x10 at 100cm SSD. Answers all very close ie approx 1% apart.

72. Multiple beam plan. AP weighted to 100% at dmax, laterals weighted to 100% at dmax. 200 cGy delivered to 238% isodose line. Dose delivered by AP beam is ??? cGy.

73. Monte Carlo calculations require a random number generator andA. probability distributions, B,C,D,E other options that didn't look right.

74. Dose 10cm deep 5cm outside field is A. 1% B. 2% C. 3% D. 4% E. 5%

75. Γ factors given on several questions were not what I expected for the isotope in question. But I always used the one given.

76. Pacemaker dose limit.

77. Apparent mCi is less / more / same as mCi

78. No shielding questions were simple "plug in and solve for B". Every one required something "non-standard" or use data in a non-standard format.

79. TG40 photon flatness specification: A 1% B 2% C 3% D 4% E 5%.

2004 Part 1 Writtens

The Physics Section of Part I consisted of 75 multiple choice questions in a three hour period. Each question was followed by five choices (A through E); there were no true/false questions. There was no differentiation between “easy type” and “hard type” questions as there has been in past ABR sample questions--there were simply 75 questions in three hours, one after another.

Several questions were dedicated to computer terminology and data management. Examples follow.

1. A CT scan with a 512x512 matrix and 300 images is compressed at 1.5:1 compression. The transfer rate is ~1.7Mbits/sec, how many minutes for the transfer? (You'd have to know the standard bit depth of a CT image).
2. A terabyte is equivalent to:
 - a. 10E4
 - b. 10E5
 - c. 10E6
 - d. 10E7
3. What category of storage is an optical disk that cannot be overwritten? WORM (Write Once, Read Many)
4. What is the name for a computer program that translates programming code into computer instructions?
 - a. Operating system
 - b. compiler
 - c. CPU

Several questions were dedicated to counting statistics and uncertainty, such as

5. If a sample has 1600 total counts in 4 minutes and the background has 900 total counts in 3 minutes, the activity of the sample is $100 \pm$ ____ cpm.
6. How many counts do you have to take of a sample to be 95% sure that you fall within 4% of your first count rate?

There was one circuit:

7. Given a diagram of a circuit consisting of a battery, a resistor, and then a resistor and an inductor in series. Values for all of the components were given. The question was: what is the current through the resistor that is in parallel with the inductor at time $\rightarrow \infty$?

There were several questions relating to basic functions, and since it was a multiple choice test, it was pretty straightforward, such as:

8. What value of t gives this function its maximum value? $Y = 2t - e^t$

There were a few questions on ultrasound, such as:

9. Ultrasound transducers transmit and receive pulses using what effect?

10. US assumes 1540 m/s, but for fat, it's really 1460 m/s. An ultrasound image shows fat as being 2 cm thick. How thick is the fat really?

There were several questions involving types of decay or interactions, such as:

11. C decays to D^* by β^+ . D^* cannot decay to the ground state by gamma emission. How can it decay?

- a. neutrino
- b. electron capture
- c. auger electron
- d. internal conversion

12. A 9.5 MeV photon passes by the nucleus of a lead atom. How many pair productions can take place?

There were a few basic isotope decay questions where you had to calculate an activity:

13. given a physical and biological half life, what remains after some time

14. given the parent half life and the much smaller daughter half life, what is the activity of the daughter in a long time?

A large number of questions related to HVL's and exponential attenuation, such as

15. given mass fractions of two materials and their attenuation coefficients, what is the combined attenuation in a compound?

16. how many HVLs is 6 TVLs?

17. If a patient is 8 HVLs thick, what's the ratio of entrance exposure to exposure at midpoint?

18. Given an isotope that emits a high energy photon and a low energy photon. The low energy photon is emitted 4 times as frequently. Attenuation coefficients are given. What's the ratio of low to high isotopes after traveling through 20 cm of water?

19. Given attenuation coefficients for lead and aluminum, how much aluminum is equivalent to x mm lead?

There were several workload-type calculations, such as:

20. A secretary's desk is behind a wall behind a chest bucky. The mR/hr is given for a 30 mA, 1 sec examination at 120 kVp. The weekly workload is 300 mA*min/wk. What's the overall exposure rate to the secretary in mR/wk?

There were several dosimeter-type questions, such as:

21. A chamber that has reached saturation is:

22. A pressurized chamber reads 90% of the incident radiation. The pressure is decreased by a factor of 10. What percent of the incident ionization does the chamber then read?

There was one dead-time question:

23. Given a measured count rate of 100,000 cps and a dead time of 2 μ s, what's the true count rate on a non-paralyzable system?

- A. 100,000
- B. 105,000
- C. 110,000
- D. 130,000
- E. 150,000

And then there were a smattering of basic physics questions, but they were simple calcs, such as:

24. What's the kinetic energy of a rotating anode with I and rotational speed given?

25. What's the decrease in density of a brick that's heated and expands 0.2% on each side?

26. If $V(r) = -130 \log(r)$ in a cylindrical chamber, what's the electric field at $r = 0.5$ cm?

And a few imaging physics questions, such as:

27. Given a list of exposures (mR) and film O.D.'s, what's the film speed?

28. Given the ODI hits a 10mm thick plastic tray of $n=1.5$ at 35 degrees, by how much is the ODI shifted at the bottom of the tray?

One item of note is that you didn't have to know any physical constants off the top of your head; they were all given to you in the problems if you needed them at all. Also, the answers given didn't seem to be designed to trick you; e.g. if you were calculating the rotating anode kinetic energy ($KE = \frac{1}{2} I \omega^2$) and you forgot to square the ω , that result was not close to a possible answer.

The Clinical Portion of Part I consisted of 50 questions in 1 hour. Most people were done in less than half of that time. I was hoping for more overlap from past exams than there was. Again, each question had 5 possible answers, no T/F.

Radiation biology/health physics had many questions, such as:

1. organogenesis occurs in ___ to ___ weeks.
2. Irradiation of 1 Gy during preimplantation most likely leads to _____.
3. The background dose excluding radon at sea level is _____ mSv/hr.
4. Dose risk estimates are based on the _____, _____ dose effects model (linear, no threshold; linear-quadratic, threshold; etc)
5. An axial CT slice containing the liver and spleen, and you were asked to pick what wasn't accurate (e.g.: it's at the level of L4).
6. A sagittal MRI that asked what's wrong.
7. What's a plexus?
8. BEIR depends on: total dose, dose rate, fraction size...
9. The following things pierce the diaphragm: spinal cord, aorta, esophagus, vena cava, trachea in various combinations
10. Where does filtered lymph reenter the bloodstream?
11. What produces estrogen?
12. What is the overall controller in the endocrine system? (pituitary, thyroid, parathyroid, hypothalamus)
13. How many temporal lobes are there? (0, 1, 2, 3)
14. What is teratogenesis?
15. Which diagnostic procedure provides the highest dose to a fetus? (Lateral spine x-ray, barium scan, upper GI)
16. What is fibromyositis associated with?

ABR Part 1 2005

The clinical exam consisted of 50 questions in 1 hour. Almost all of the questions were repeats from previous exams. I finished this part in 15 minutes and thus had plenty of time to review my answers several times.

The physics exam consisted of 75 questions in 3 hours. The first 50 questions were worth 1 point each and a total of 40% of the total score. The last 25 questions were worth 3 points each and a total of 60% of the total score. I am a slow test taker and had just enough time to finish the exam (I had two minutes remaining when I answered the 75th question). After talking to a few other test takers it seems that the average person finished with 10-15 minutes to spare, which they used to look at their flagged questions.

Good luck!

Clinical Part I

1. What valve admits blood into the left ventricle?

- A. tricuspid
- B. mitral
- C. aortic
- D. pulmonary

2. Where is the hilum located?

- A. Chest
- B. Abdomen
- C. Brain
- D. Neck
- E. Diaphragm

3. What procedure is used to confirm a hiatal hernia?

- A. Doppler US
- B. IVP
- C. Upper GI

4. There are ___ cranial nerves.

5. There are ___ lumbar vertebrae.

6. There are ___ thoracic vertebrae.

7. Irradiation during what time during gestation is congenital malformations most likely to occur?

- A. 0-10 days
- B. 10-18 days
- C. 18-45 days
- D. 70-150 days
- E. after 150 days

8. A T2 MRI image is shown. What statement is true about this image?
- A. Bone has a high signal
 - B. The optic nerve has a high signal
 - C. There is low signal in the vitreous humor
 - D. Gray matter has a higher signal than white matter
9. How does the blood flow through the heart?
- A. Right ventricle -> Right atrium -> Left ventricle -> Left Atrium
 - B. Left Atrium -> Left Ventricle -> Right Atrium -> Right Ventricle
 - C. Left Ventricle -> Left Atrium -> Right Atrium -> Right Ventricle
 - D. Right Atrium -> Right Ventricle -> Left Atrium -> Left Ventricle
 - E. Left Atrium -> Right Atrium -> Right Ventricle -> Left Ventricle
10. Which vessel is the most oxygenated?
- A. Aorta
 - B. Pulmonary Artery
 - C. Pulmonary Vein
 - D. Portal Vein
11. Hematocrit measures the percent of ____ in the blood.
- A. Platelets
 - B. Plasma
 - C. Red blood cells
 - D. White blood cells
12. Which organ produces insulin?
13. In most adults, where are red blood cells produced?
14. What is the main function of the spleen? (Besides its role in the lymphatic system)
- A. Filter red blood cells
 - B. Produce bile
 - C. store fats
15. Which is the earliest skin reaction to ionizing radiation?
- A. erythema
 - B. dry desquamation
 - C. moist desquamation
16. The most radiosensitive stage of the cell cycle is the ____ phase.
- A. M
 - B. G2
 - C. G1
 - D. S

17. Which tissue is the most radiosensitive?
- A. breast
 - B. haemopoietic
 - C. skin
 - D. GI
 - E. brain
18. What is a neoplasm that does not spread called?
19. Which statement best describes dysplasia?
20. The joining of two ends of a severed body tube is called:
- A. an arthrosis
 - B. an anastomosis
 - C. an anastial ptosis
 - D. a tubal ligation
 - E. a canthosis
21. A CT is shown. Which label is incorrect? (This was very obvious. A label at the colon was listed in the answer choices as the label for the aorta)
22. Which nodes are most often removed in a mastectomy?
23. Which tissue is breast cancer most associated with?
- A. Adipose
 - B. Ductal
24. Two survival curves are shown on the same graph. What quantity is the same for both curves?
25. What prominent land mark is the iliac crest associated with?
26. An EEG measures:
27. Nerve cells move voluntary muscles by:
28. What is the most damaging product of radiation induced hydrolysis?
- A. Oxygen free radical
 - B. Hydrogen free radical
 - C. hydroxyl free radical
 - D. pertechnetate free radical
29. People with high lifetime exposures to radon may have high readings of radon activity in their:
- A. breath
 - B. feces
 - C. saliva
 - D. sweat

30. In the 1930's many tuberculosis patients were exposed to multiple fluoroscopy exams. These patients are likely to have a higher incidence of:

- A. breast cancer
- B. esophageal cancer
- C. thyroid cancer
- D. bone cancer

31. Which cancer will have the highest CT number?

- A. astrocytoma
- B. osteosarcoma

32. Where are the adrenal glands?

33. Which is not part of the upper extremities?

- A. radius
- B. ulna
- C. metacarpal
- D. patellar

34. Where is the foramen magnum?

35. Gray matter is a common term for:

- A. meninges
- B. forebrain
- C. cerebral cortex
- D. brain stem
- E. corpus callosum

36. Where is the pituitary gland?

- A. brain
- B. abdomen
- C. chest
- D. neck

37. A loss of equilibrium is most likely associated with _____.

- A. brain stem
- B. cerebellum
- C. cerebrum
- D. frontal lobe
- E. occipital lobe

38. Where is the visual cortex located?

- A. frontal lobe
- B. parietal lobe
- C. occipital lobe
- D. temporal lobe
- E. cerebellum

39. Where does blood from the pulmonary artery come from?

- A. right ventricle
- B. left ventricle
- C. aorta
- D. right atrium

40. A creatinine test is acquired before a contrast study to:

41. A blood clot traveling through the body is called:

- A. thrombus
- B. embolism

42. Gas exchange between the lungs and the body occurs via:

- A. osmosis
- B. diffusion

43. Where/what is the circle of Willis?

44. Where are the glomeruli found?



General Physics Part I

1. Given an observed count rate of X cps and a dead time of 1.2×10^{-4} s, what is the true count rate?

2. A graph of velocity versus time is given. What is the distance traveled?

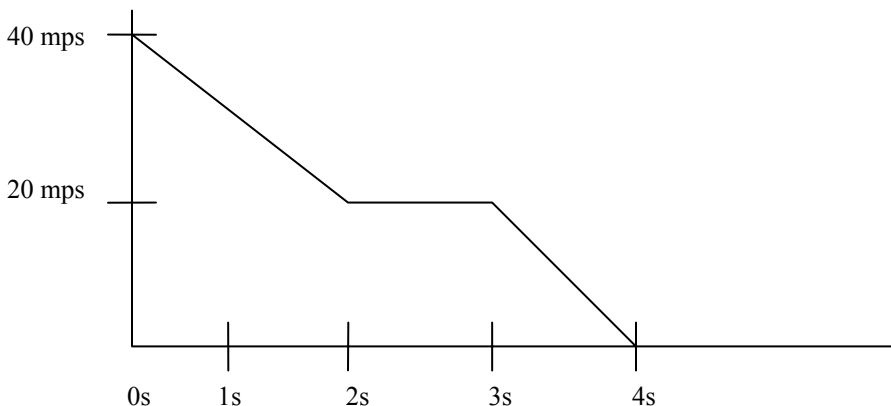

3. RC circuit. With reference to the circuit below, if the switch has been closed for a while, what is the initial current in the circuit once the switch is opened (R , C , and Battery Voltage given)?

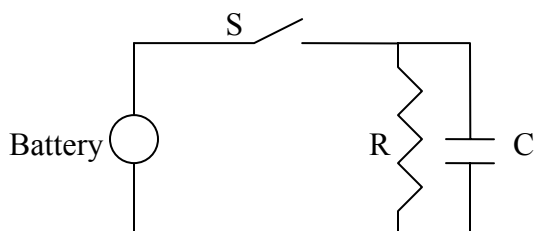

4. Two batteries in series are bucking each other with a resistor. The current and battery voltages are given. If one of the batteries is switched, what is the new current?
5. Given a capacitance and a battery voltage, what is the charge in the system?
6. How many memory locations can a two byte word access?
7. 1 byte equals:
A. PC Word
B. ASCII
C. 3 octet places
D. 4 hexadecimal places
8. Parity is used in data transfer protocol for what purpose?
A. data block division
B. integrity
9. A high voltage supply accepts two inputs and produces one output. The output is “HI” if both the inputs are “HI” or if either of the inputs are “HI”. This is a _____ system.
A. OR
B. NOR
C. NOT
D. AND
E. NAND
10. Air kerma is 5 mGy. What is the exposure?
11. An X MeV photon interacts with a free electron in air. How many ions are produced by the scattered electron?
12. An X MeV photon interacts with a free electron in **soft tissue**. How many ions are produced by the scattered electron?
13. A 6 MeV alpha particle produces 10,000 ion pairs. What is the range of the alpha particle?
A. 0.03 mm
B. 0.3 mm
C. 3.0 mm
D. 30.0 mm
E. 300.0 mm
14. The most absorbed dose caused by fast neutrons is from:
A. neutron activation
B. radioactive decay
15. What is the probability that a photon will interact between 1 and 2 cm of tissue?
(the attenuation coefficient is given)
16. What decay process competes with electron capture?

17. A sample is made up of radioisotope X and radioisotope Y. Each isotope has an activity of 400 MBq. The sample, radioisotope X, and radioisotope Y are measured for 10 minutes and results in the following number of counts in two different energy windows, A and B. There are _____ MBq of radioisotope Y present in the sample.

	A	B
X	30,000	5,000
Y	0	50,000
Sample	60,000	60,000

18. If the diameter and length of a wire are both doubled, the resistivity of the wire changes by a factor of _____.

- A. 4
- B. 2
- C. 1
- D. 0.5
- E. 0.25

19. The dose rate at an assistant's desk is 5 mGy/hr from an x-ray unit set at 100 mA and 120 kVp. A typical chest x-ray is taken with 120 kVp and 3.5 mAs. For 200 chest x-rays, what is the dose at the assistant's desk?

20. Given the mass of ^{15}N and ^{15}O in amu, what is the maximum energy of the positron emitted when ^{15}N decays to ^{15}O ?

21. A 1.25 MeV photon interacts with a free electron at a 30° scattering angle. What is the energy of the scattered photon after this interaction?

22. Given attenuation coefficients for a couple of materials, what is the effective attenuation coefficient?

23. An x-ray beam is composed of two energies. Given the attenuation coefficients of these energies, what is the effective energy of the beam?

24. The TVL of concrete is 18 cm and the TVL of lead is 1.2 mm. What is the amount of transmission for 30 cm of concrete plus 5 mm of lead?

25. What is the Larmor frequency of a 1.6 Tesla MRI scan?

26. For a 2 T MRI scanner, the inhomogeneity is 10 ppm. Therefore, the inhomogeneity in the acquisition is +/- _____ Hz.

27. According to the uncertainty principle, what two quantities cannot be known simultaneously?

- A. position and time
- B. position and momentum
- C. time and momentum
- D. velocity and time

28. What is the purpose of guard rings in an ion chamber?

29. An US beam encounters a muscle / fat interface with an incident angle of 30 degrees. What is the angle of the transmitted beam? (The velocities of each material is given)
30. Doppler Effect: A source with a frequency of 400 Hz is moving toward a stationary observer with a speed of 27 m/s. What frequency does the observer hear? (The velocity of sound in air = 331 m/s and was given for the problem)
31. Besides electron capture, what else can cause K shell electron vacancies?
32. Evaluate this integral with $r = 5$ cm: $0.0024 * \int r (10r - r^2) dr$
33. What statement is true about a magnetic moment?
34. The specific exposure of an isotope is 1.5. What is the exposure at 100 cm if the isotope has an activity of 10 mCi?
35. The physical half-life of an isotope is 13 hours. The initial activity of an isotope is X and the activity after 12 hours is Y. What is the biological half-life?
36. An initial activity of X mCi is injected into a patient. After 10 hours the activity concentration is Y mCi/liter. The biological half-life is Z. The patient has 6 liters of blood. What is the physical half life?
37. Given organ doses and their weights, what is the cumulative dose?
38. What number of counts is needed for the noise to be less than 0.1%?
39. The mean value of a Gaussian distribution is 10,000. What percent of the counts will have a value of 9900 or less?
40. The entrance exposure to a patient is 4 mGy. The exit dose is 0.25 mGy. What is the dose at the midline of the patient, given that the patient is 22 cm thick?
41. A prostate implant has a half-life of 3.5 days. What percent of the dose is delivered in the first day?
42. What is the rest mass energy of ^{12}C ? (Given that 1 amu = 931 MeV)
43. For a particular cell line $D_0 = 50$ Gy. What is the percent survival after 100 Gy is delivered to this cell line?
44. Calculate kerma given the photon flux, energy of the photon, the linear attenuation coefficient and the transfer attenuation coefficient.
45. The specific heat of water is X (J/kg * °C). What dose is needed to raise the temperature 10° ?
46. The dose at a temperature of 23° C and a pressure of 720 mmHg is X. What is the dose at standard temperature and pressure?
47. 120 Kelvin is _____ °F.

48. The density of air is 1.23 kg/m^3 , the exposure rate is 10 R/hr , and the current collected in an ion chamber is 2.0 amperes . What is the volume of the chamber?

49. A wire is placed over a CT FOV such that it is 30° from normal. The CT slice thickness is 5 mm . What is the apparent length, L , of the wire?

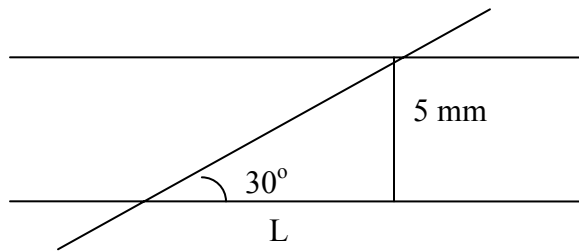

50. What is true about the magnetic field at large distances?

51. Which ionizing radiation has a spectrum of energies?

52. The activity of a radioisotope is $X \text{ Bq}$. The half life is Y . How many atoms are there?

53. Why is plastic used to ship nuclear generators? (i.e. why not lead?)

54. A mammography screening is typically a dose of 5 mGy . If a person undergoes 20 screenings, what is the percent probability of induced carcinogenesis?

55. In fluoroscopy, what is the main source of dose?

- A. patient
- B. leakage
- C. collimator scatter

56. Sensitivity is also known as the ____ fraction.

- A. True Positive
- B. True Negative
- C. False Positive
- D. False Negative

57. A particle does not emit electromagnetic energy if it travels:

- A. linear, constant velocity
- B. linear, constant acceleration
- C. circular, constant velocity
- D. circular, constant acceleration

58. What is the optical density of a film where the transmittance is 10%?

59. What is the decibel change when the intensity level is 10% of the original intensity?

60. A CT given at 100 mAs produced an image with a noise value of 1.5 . If the slice thickness is doubled and the mAs are increased to 400 mAs , what is the noise in the image?

ABR radiation therapy physics, part I, August 22, 2005, afternoon.

Many questions were similar to those in the end (say last 100 pages) and in the very beginning of the Guide.

Clinical, 50 questions, 1h. Time given was plenty.

1. Serum creatinine test is used because of the risk of ____

- A. Dehydration
- B. Renal failure
- C. Stroke

2. Blood circulation through heart

Answers: light/left atriums/ventricles in different orders

3. Given two log-log plots of the survived fraction vs. dose say what's common for two plots.

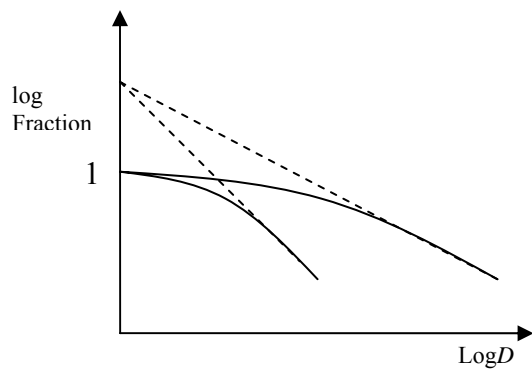

4. Opening in the calvarium

- A. Foramen magnum

5. A clot in the blood is called

- A. Plaque
- B. Emboli

6. Hematocrit is

- A. Platelets
- B. Red blood cells
- C. White blood cells

7. Forearm bones are

There was radius and ulna option

8. Joints of bones, capillaries

Anastomosis?

9. In ^{226}Ra treatment where is ^{222}Rn expected?

- A. Feces
- B. Exhale

C. Sweet

10. Lung oxygen transport

A. Diffusion

B. Osmosis

C. Active transport

11. Bone not in upper extremities

A. Patella

12. How many lumbar?

1 3 5 7

13. How many cranial?

14. Where is sacrum?

A. T10-T12

B. L4-L5

15. How to diagnose Hiatal Hernia (no Ba scan, which IMHO could be an answer, option)

16. What is the primary function of spleen?

17. Where is pituitary gland

A. Abdomen

B. Head (or brain)

C. Legs

18. Where is insulin produced?

A. Liver

B. Pancreas

C. Bone marrow

D. Spleen

19. Breast cancer – what tissue?

20. What tumor has the highest intensity (or easy to see?) on CT

A. Osteoma?

21. Most oxygenated blood is in

A. Aorta

B. Pulmonary artery

C. Pulmonary vein

22. What prevents the blood from coming back from left ventricle or something like that.

A. Mitral

23. Where is visual cortex?

A. Cerebellum

B-D Lobes

24 question on CT (find incorrectly labeled structure in abdomen)

25 Question on MRI, like optical nerve is dark etc.

26. Circles of Willis

27. What is the example of the stochastic effect of radiation?

28. NCRP eye limit is because of the _____ effect of radiation

- A. Stochastic
- B. Deterministic
- C. Cancerous

Physics, 75 questions, 3h. Well, time was enough for a single pass, but I could not go through all flagged questions during the second pass.

1. Dose estimation on radiologist desk. 1 scan: 35 mAs produces 5 mGy / h on radiologist desk. How much per 200 exposures if each is taken at 100 mA?

2. Compton, original photon is 1.25 MeV, scattered at $30.^\circ$ What is the energy of scattered photon? No equation given.

3. Need to digitize with the resolution of 0.1% of the average and maximum of 4 times average. How many bits are necessary? (6 8 10 12)

4. Under what conditions charged particle in vacuum does **not** emit radiation?

Answer: Combinations of constant/changing speed, accelerating/decelerating/no acceleration

5. $D_0 = 50$ Gy, how many will survive at 100 Gy? No word about D_1 .

6. Given mass in amu of n, p, e (and $\text{amu} \cdot c^2$ in MeV) find the binding energy of ^{12}C in MeV.

7. Initial activity of an ^{123}I sample ($t_{1/2} = 13$ h – given) injected in the blood is 480 MBq. After 12 h measured activity is 20 MBq / l. Assuming the volume of the blood is 6 l find biological half-life, h.

- A. 4
- B. 6
- C. 9
- D. 11
- E. 13

8. 10000 cpm, 100 measurements are made. 95% are within ± 200 cpm. What type of the error is it?

- A. Systematic
- B. Analytic
- C. Random
- Etc.

9. What is parity check for?

- A. Compression
- B. Data integrity

10. 16-bit PC – how many can be directly addressed?
11. Initial activity, $t_{1/2}$, find activity at time T ?
12. Given μ (two numbers are given μ_{tr} and μ) energy, fluence – find Kerma.
13. Given activity and half-life calculate N .
14. Given μ calculate the probability of the photon to be absorbed between 1 cm and 2 cm.
15. Source: 2 R / (s mCi) at 1 cm. What is the exposure rate in R / h at the distance 50 cm, if 4 mm Pb shielding is present. HVL of lead (2 mm) was give.
16. Ion chamber, which at exposure rate of 10 mR / s, gives 1 nA current. Calculate volume.
17. V (10 V) and C (20 μ F) given – calculate Q.
18. What is the voltage at A just before switch S is opened.

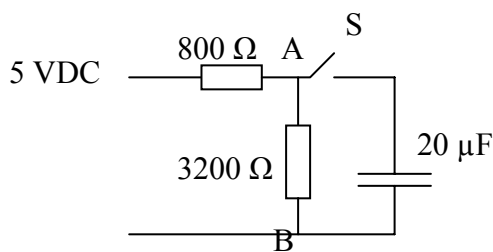

19. 28°C, 720 mm Hg, ion chamber gives 10 nC. What is the corrected charge?
20. Convert 120 K to F.
21. Magnetic moment distribution depends upon B and
 - A. Boltzman
 - B. Puasson
 - C. Boson
22. 10000 cpm, what is probability that it's below 99900? (erf not given)
 - A. 16%

That's the question I did not get

23. CT 100 mAs of an object with constant electron density gives standard deviation of 1.5 HU. What will be standard deviation (in HU) for a slice with the double thickness and 400 mAs?
 - A. 1.06
24. What are guard rings for parallel plates IC?
25. 1 MeV photon, Compton, 90°. How many pairs will produce this electron?

- A. 10
- B. 100
- C. 1000
- D. 10000

26. β^+ decay, O \rightarrow N, masses given. Find E_{max} , (they did not even give 2.7 MeV as an option for an answer)

27. What radiation has continuous spectrum?

- A. α
- B. β^+
- C. Auger
- D. Fluoroscopic
- E. Characteristic

28. Why Pb better than plastic for shielding β^+ ?

- A. Wight
- B. Price
- C. Glass won't break
- D. Braking radiation

29. α , 6 MeV produces 20000 pairs per cm. Find range.

30. Slice thickness is 5 mm. Find apparent length L of the wire at 38°

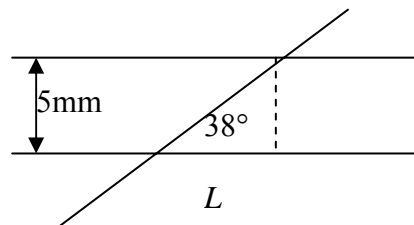

31. Dose to heat water 10°C . ($4.2 \text{ kJ} / \text{kg K}$ – given)

32. Magnetic field inhomogeneity, 10 ppm, 1.6 T, find frequency. There were two MRI question on the test and in first of them 43 MHz was not given, while in second it was.