

ICRU Cervical Intracavitary Dose Reporting Recommendations

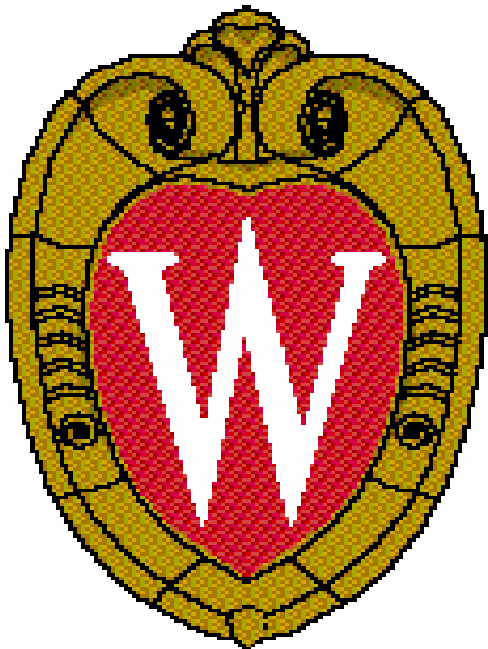

Bruce Thomadsen

University of Wisconsin
Madison

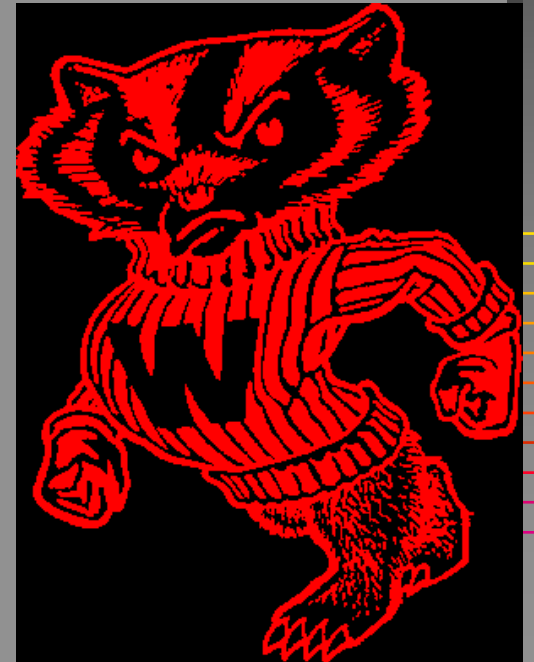

Conflict of interest and Learning Objectives

- The presenter has no known conflicts affecting this presentation.
- The learning objectives are:
 - To understand the ICRU Reporting recommendations,
 - To understand the ABS recommendations

For cervical cancer intracavitary brachytherapy reporting.

Reporting

- The ICRU reporting recommendations are *only* to facilitate communication of the “nature” of a patient’s treatment, or a summary of a group of patients.
- It is not a brachytherapy system, nor a method of prescription.

Specifying Amount of Radiation Given

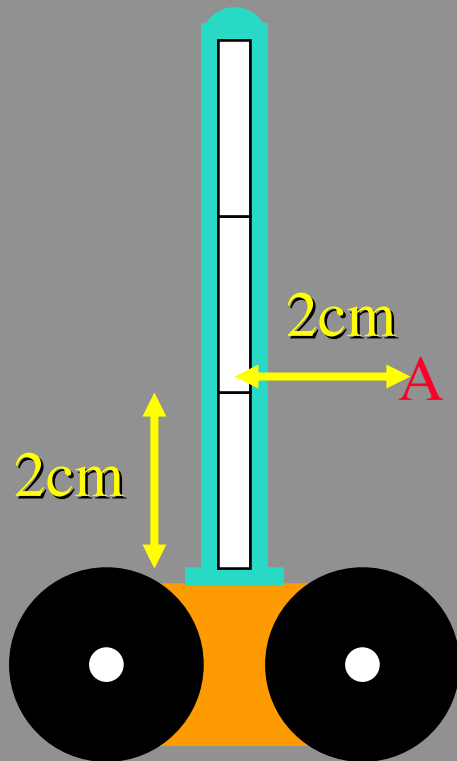

- We here are most used to looking at the dose to a point, for example, the Manchester Point A.
- Alternatively, we might consider the total reference air kerma ($TRAK=IRAK=U \times \text{time}$ for long half-life materials, similar to $\text{mg}\cdot\text{h}$)

Specifying Amount of Radiation Given

Alternatively, one could look at how far a dose is thrown for the applicator.

Point-Volume Dose Specification

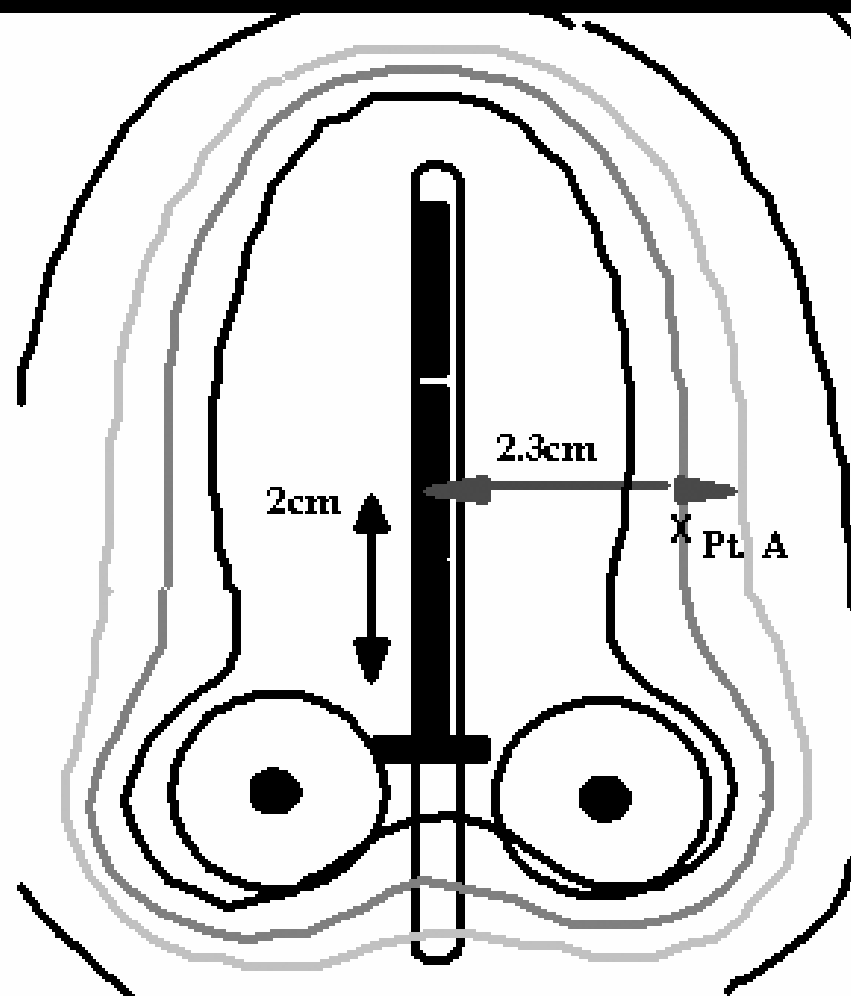
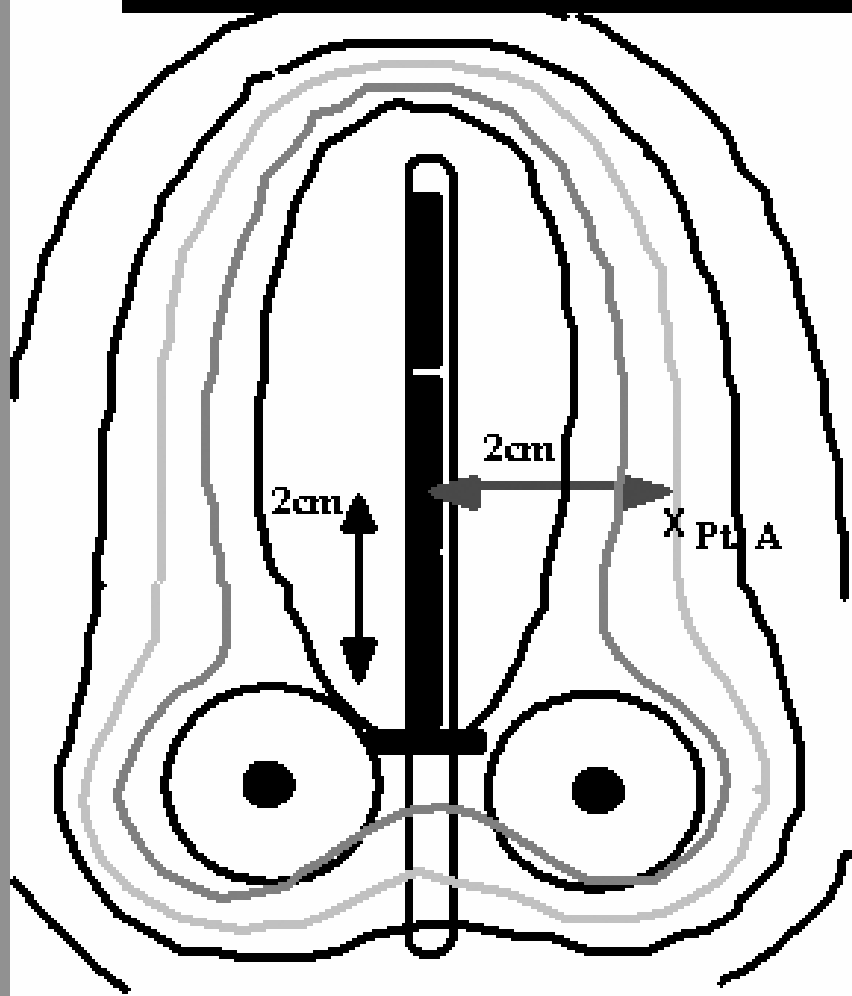

ICRU Treatment Dimensions

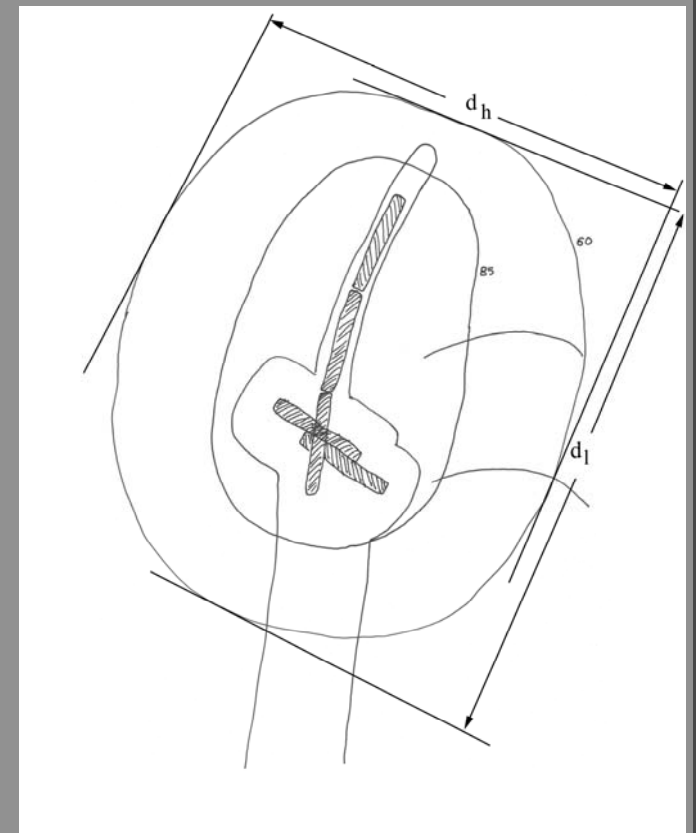
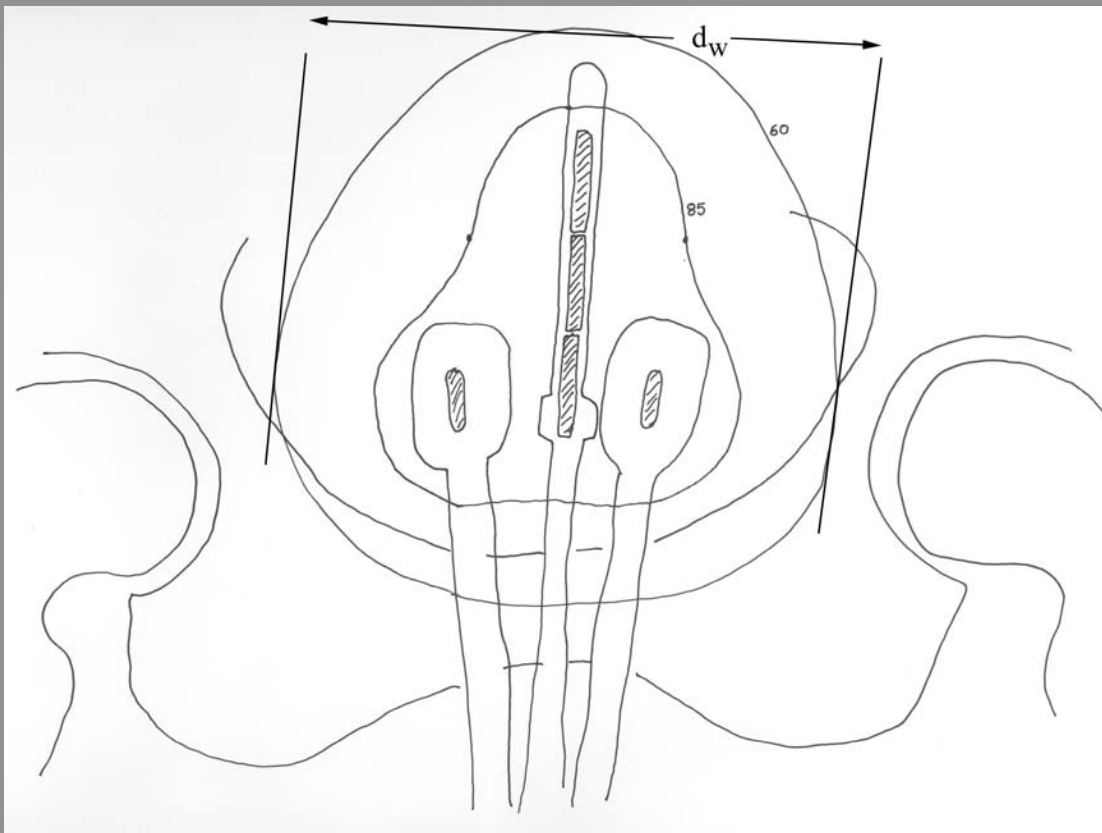

ICRU Intracavitary Dose Specification

- Specifies the maximum dimensions of the 60 Gy isodose surface: width through ovoids, orthogonal height and length.
- NOT a volume!!!
- Only meant to indicate the “amount” of dose given.
- Equivalent to specifying the dose at a fixed distance, sort of.

Bladder and Rectal Points

Bladder point:
Bottom of the
Foley bulb

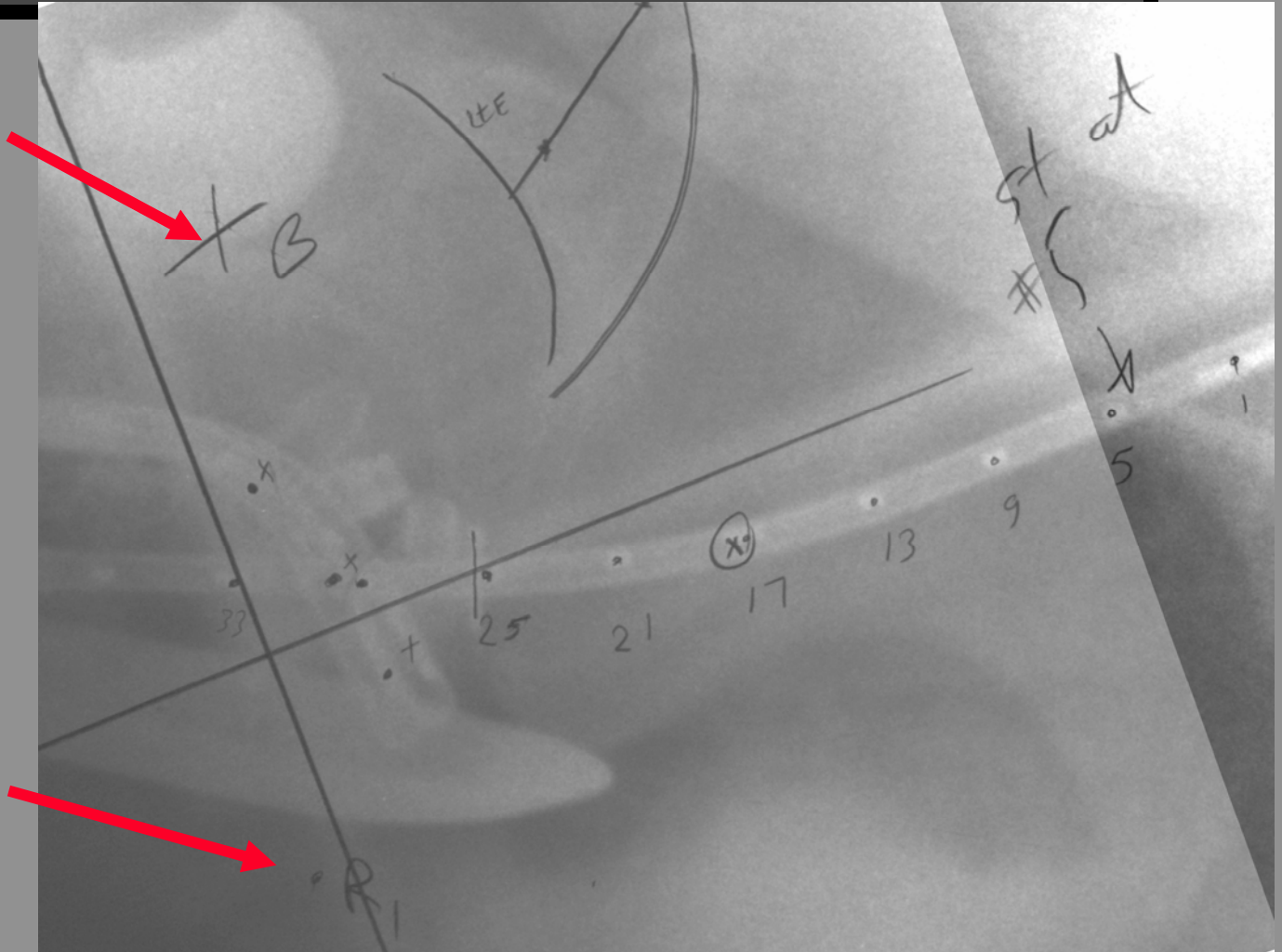

Rectal point:
0.5 cm below
the posterior
vaginal wall at
mid-ovoid

ICRU Bladder Point

- Use a Foley Bulb in the trigone of the bladder with about 7 cc of dilute contrast medium.
- The point is the posterior aspect.
- This location does not represent the hottest part of the bladder.
 - That usually falls about 2 cm superior.
 - The highest dose often is about 2-4 *times* the dose at the bulb.

ICRU Rectal Point

- Falls 0.5 cm posterior to the vaginal wall at the level of the mid-ovoid.
- Doesn't usually represent the maximum rectal dose, which, again often is 2-4 cm cephalad.
- The maximum dose is up to 3 times the ICRU point (but more often closer than the ICRU bladder dose).

Pelvic Wall Points

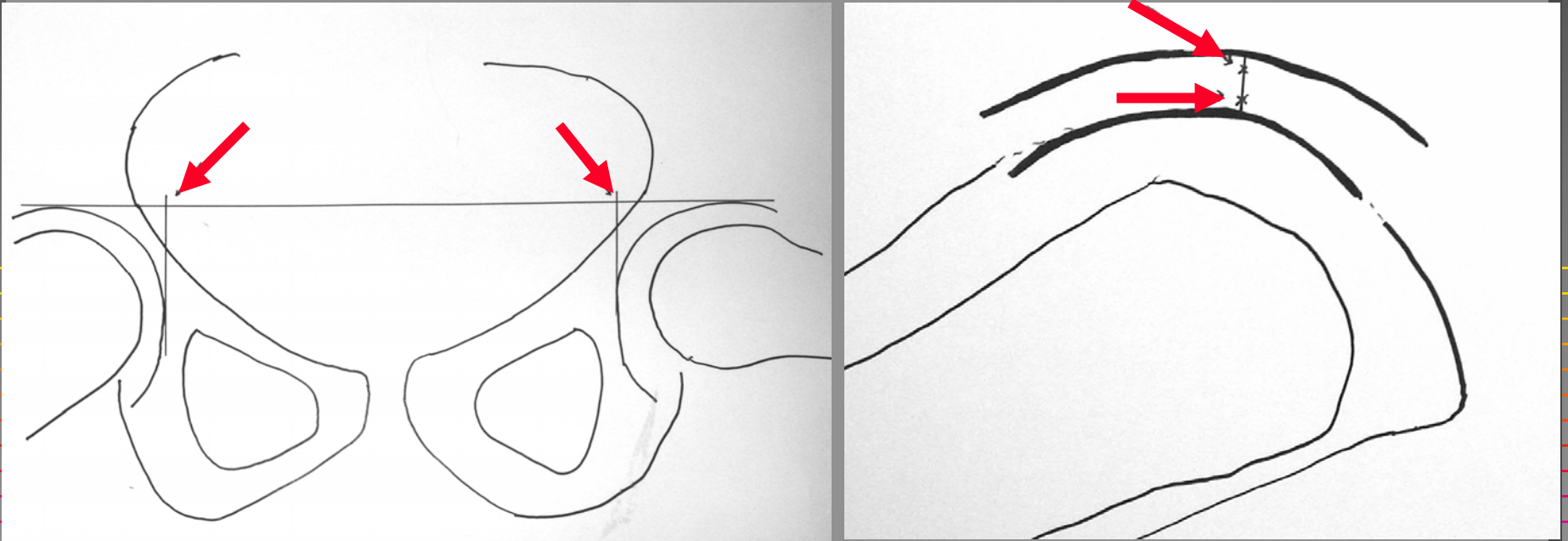

Lymphoidal Triangle

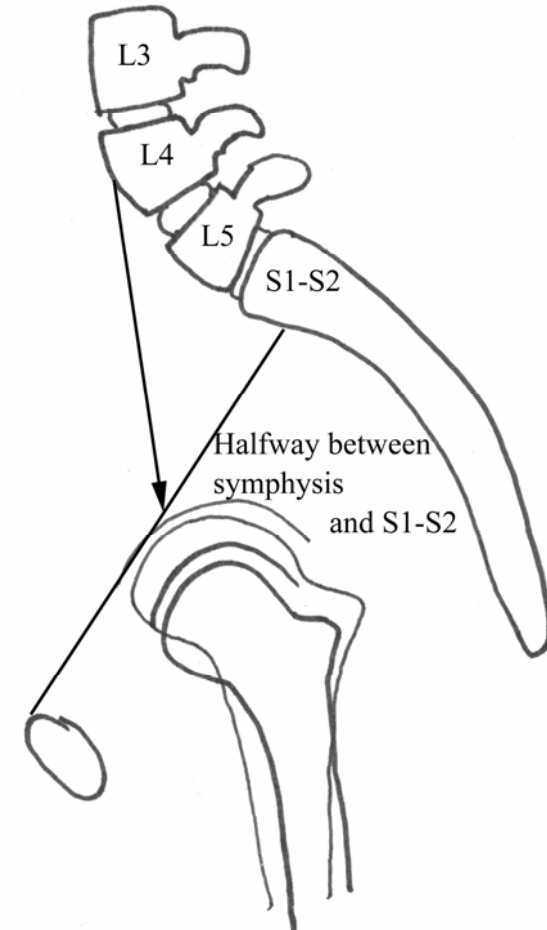
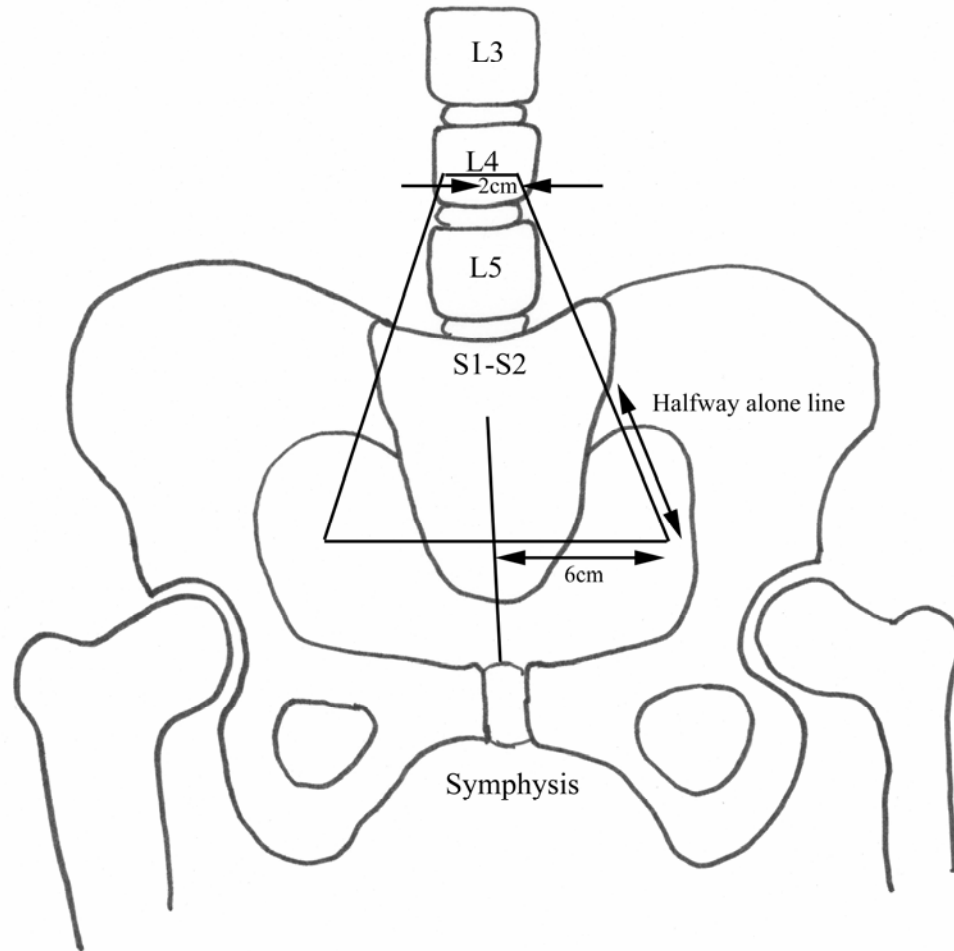

ABS Recommendations for HDR Cx Brachytherapy: 1

1. Brachytherapy must be included as a component of the definitive radiation therapy for cervical carcinoma.
2. Good applicator placement must be achieved to obtain improved local control, survival and lower morbidity.
3. HDR should be interdigitated with pelvic EBRT to keep the total treatment duration to less than 8 weeks.

ABS Recommendations for HDR Cx Brachytherapy: 2

4. The relative doses given by EBRT versus brachytherapy depend upon the initial volume of disease, the ability to displace the bladder and rectum, the degree of tumor regression during pelvic irradiation, and institutional preference.
5. Interstitial brachytherapy should be considered for patients with disease that cannot be optimally encompassed by intracavitary brachytherapy.

ABS Recommendations for Locating Point A

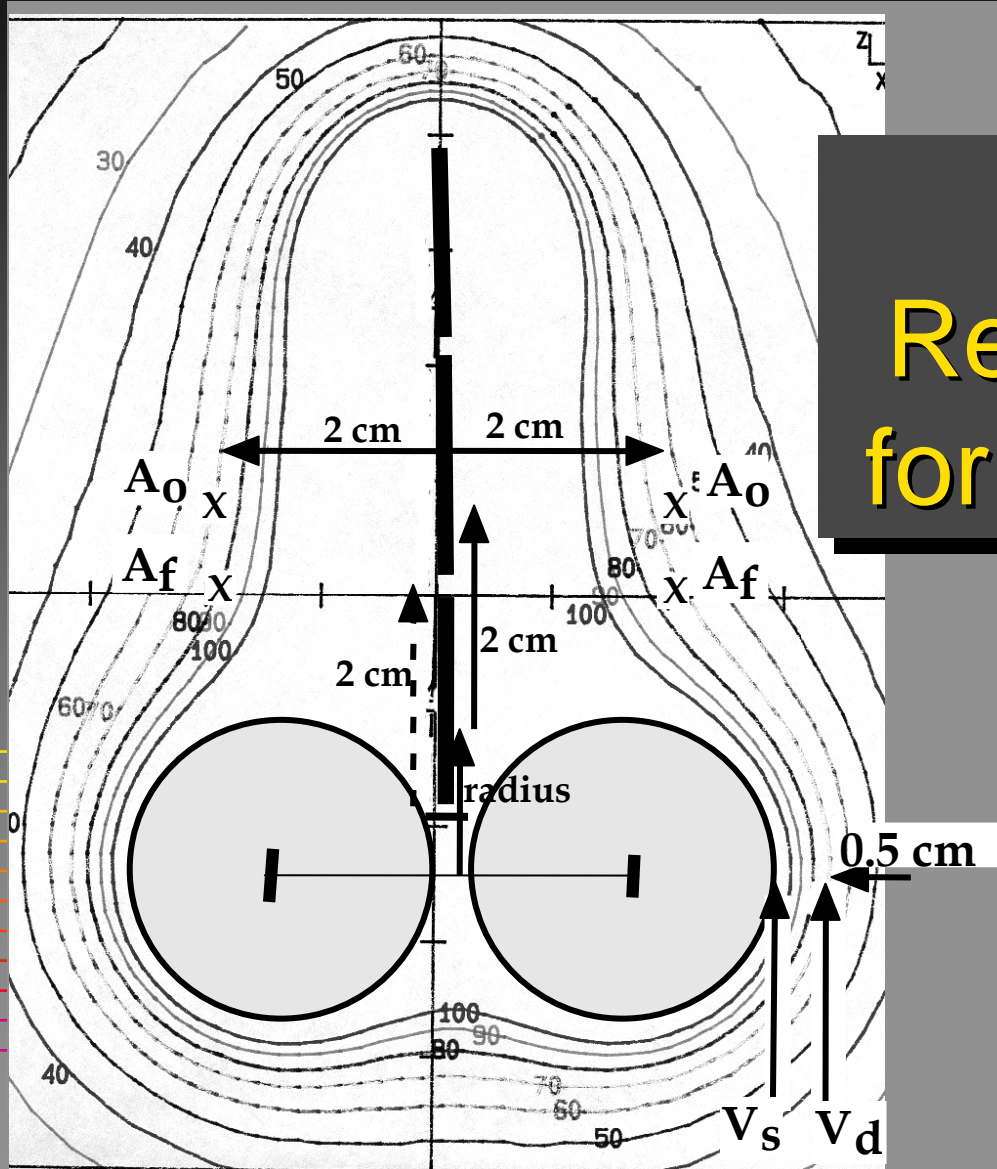

Manchester Applicator and Point A

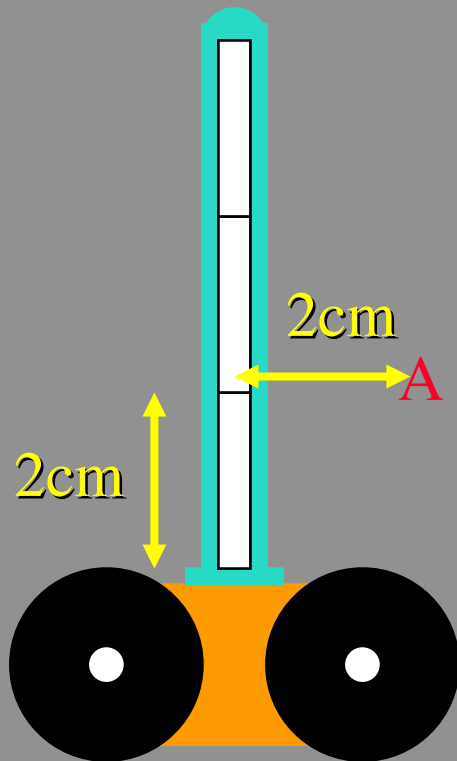

- Finding A originally started at the line joining the superior points of the ovoids.
- Later moved to the bottom of the inferior-most sources.
- The two methods are the same *for the Manchester Applicator*.

Tandem and Cylinders

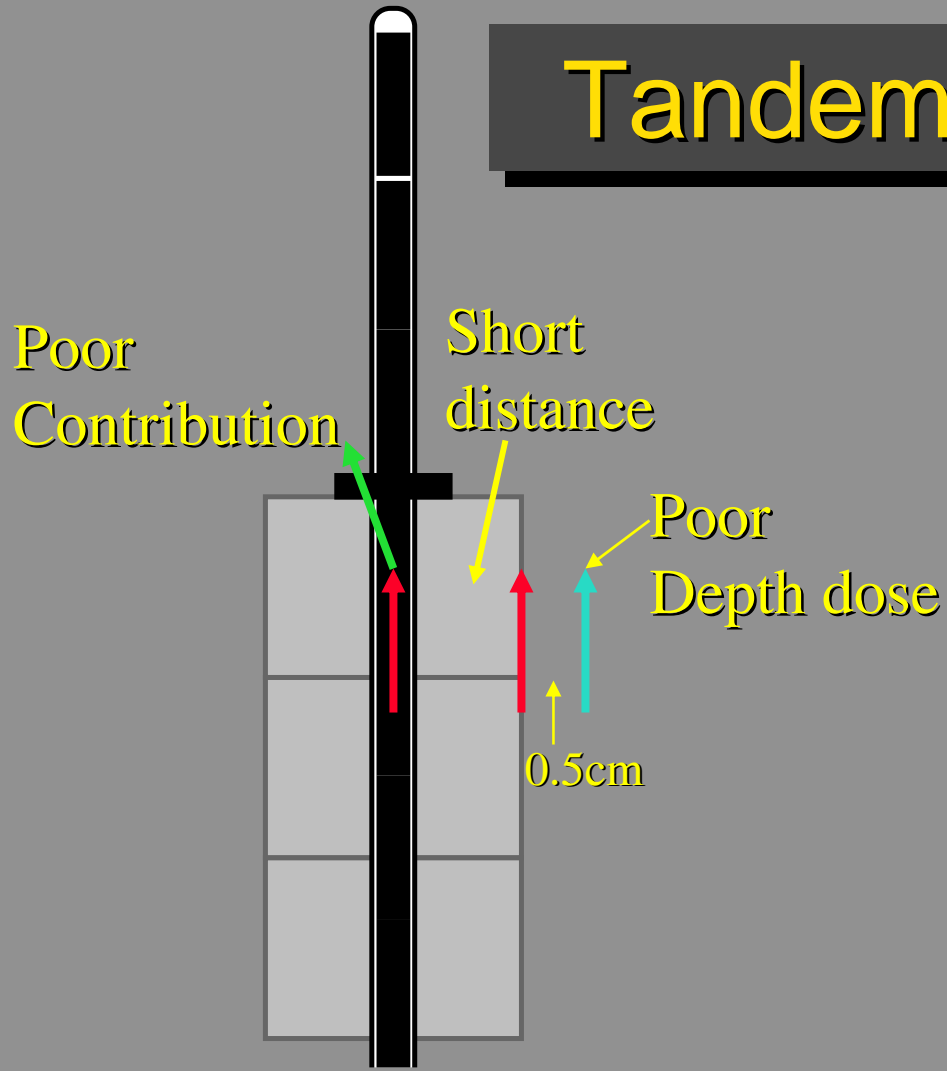

Because of the nature of the anisotropy, this maximizes the relative contribution to the bladder and rectum per dose to cervix, and usually prevents adding distance to those organs.

Physical Information

- Sources
 - Radionuclide
 - Reference air kerma for each source
 - Model of each source
 - If point-like sources or moving sources, the pattern of sources or movement.
- Applicator
 - Model, if description has been published
 - Otherwise,
 - » If rigid as a whole
 - » Whether the tandem is rigid with a fixed curvature
 - » Connection between the tandem and vaginal appliance
 - » Number and orientation of vaginal sources
 - » Shielding in the vaginal appliance.
- Total Reference Air Kerma